

Series



Features

- Available in E12 values
- Inductance range as low as 1.0 μH
- Current rating to 9.4 amps
- RoHS compliant*

Applications

- Input/output of DC/DC converters
- Power supplies for:
 - Portable communication equipment
 - Camcorders
 - LCD televisions
 - Car radios

SRR1260 Series - Shielded SMD Power Inductors

Electrical Specifications

Bourns Part Number	Inductance 100 kHz		Q (Typ.)	Test Freq. (MHz)	SRF Typ. (MHz)	RDC Max. (m Ω)	I rms Max. (A)	I sat Typ. (A)
	(μH)	Tol. (%)						
SRR1260-1R0Y	1.0	± 30	26	7.96	100.00	7.8	9.40	10.00
SRR1260-1R2Y	1.2	± 30	18	7.96	91.10	8.0	9.20	9.80
SRR1260-1R5Y	1.5	± 30	24	7.96	86.00	9.5	8.80	9.90
SRR1260-2R2Y	2.2	± 30	22	7.96	70.00	10.5	8.20	8.50
SRR1260-2R4Y	2.4	± 30	18	7.96	63.80	11.5	7.80	8.00
SRR1260-3R3Y	3.3	± 30	20	7.96	40.00	12.0	7.60	7.80
SRR1260-3R5Y	3.5	± 30	22	7.96	37.60	13.0	7.50	7.60
SRR1260-4R7Y	4.7	± 30	19	7.96	36.70	15.5	6.80	7.00
SRR1260-5R6Y	5.6	± 30	19	7.96	33.00	16.2	6.70	6.90
SRR1260-6R1Y	6.1	± 30	21	7.96	29.80	17.0	6.60	6.80
SRR1260-6R8Y	6.8	± 30	20	7.96	28.20	18.0	6.30	6.50
SRR1260-7R6Y	7.6	± 30	16	7.96	27.90	19.0	6.00	6.20
SRR1260-8R2Y	8.2	± 30	18	7.96	24.00	19.5	5.70	5.80
SRR1260-100M	10.0	± 20	32	2.52	21.00	20.0	5.50	5.50
SRR1260-120M	12.0	± 20	27	2.52	19.40	23.0	5.20	5.00
SRR1260-150M	15.0	± 20	25	2.52	17.60	27.0	5.00	4.60
SRR1260-180M	18.0	± 20	28	2.52	15.50	36.0	4.20	3.90
SRR1260-220M	22.0	± 20	29	2.52	13.40	43.0	4.00	3.70
SRR1260-270M	27.0	± 20	26	2.52	12.70	45.0	3.60	3.30
SRR1260-330M	33.0	± 20	27	2.52	9.97	60.0	3.00	2.80
SRR1260-390M	39.0	± 20	22	2.52	10.40	70.0	2.80	2.70
SRR1260-470M	47.0	± 20	22	2.52	7.63	86.0	2.60	2.50
SRR1260-560M	56.0	± 20	24	2.52	7.92	100.0	2.30	2.20
SRR1260-680M	68.0	± 20	22	2.52	7.43	110.0	2.10	2.10
SRR1260-820M	82.0	± 20	25	2.52	6.85	145.0	1.95	1.90
SRR1260-101M	100.0	± 20	26	0.796	6.07	180.0	1.70	1.70
SRR1260-121K	120.0	± 10	26	0.796	5.50	210.0	1.65	1.65
SRR1260-151K	150.0	± 10	20	0.796	5.00	260.0	1.55	1.55
SRR1260-181K	180.0	± 10	26	0.796	4.50	320.0	1.40	1.40
SRR1260-221K	220.0	± 10	22	0.796	4.20	380.0	1.38	1.30
SRR1260-271K	270.0	± 10	20	0.796	3.60	450.0	1.30	1.20
SRR1260-331K	330.0	± 10	22	0.796	3.20	580.0	1.15	1.10
SRR1260-391K	390.0	± 10	20	0.796	2.80	700.0	1.08	1.00
SRR1260-471K	470.0	± 10	18	0.796	2.60	820.0	0.95	0.90
SRR1260-561K	560.0	± 10	22	0.796	2.40	1000.0	0.88	0.80
SRR1260-681K	680.0	± 10	18	0.796	2.20	1150.0	0.80	0.75
SRR1260-821K	820.0	± 10	20	0.796	2.00	1500.0	0.73	0.63
SRR1260-102K	1000.0	± 10	30	0.252	1.80	1700.0	0.68	0.60

General Specifications

Test Voltage 0.1 V
 Operating Temperature -40 °C to +125 °C
 (Temperature rise included)
 Storage Temperature -40 °C to +125 °C
 Resistance to Soldering Heat +260 °C for 10 sec.
 Temperature Rise 40 °C max. at rated I rms
 Inductance Drop 25 % typ. at I sat

Materials

Core Ferrite DR and RI
 Wire Enameled copper wire 130
 Terminal Cu/Ni/Sn
 Packaging 600 pcs. per reel

Product Dimensions

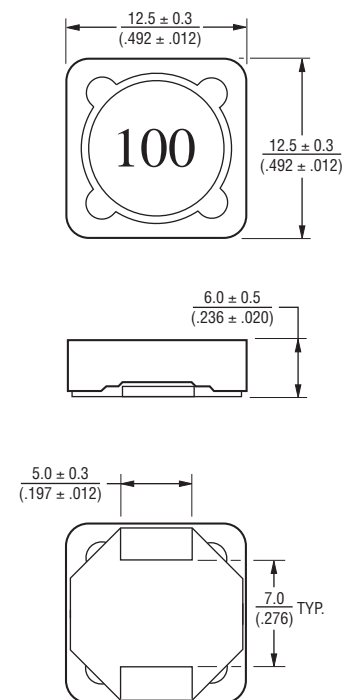

Electrical Schematic

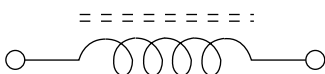

Recommended Layout

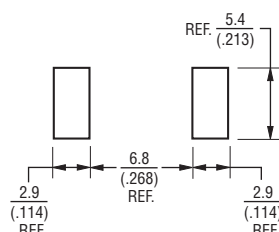

* RoHS Directive 2002/95/EC Jan. 27, 2003 including annex and RoHS Recast 2011/65/EU June 8, 2011. Specifications are subject to change without notice. The device characteristics and parameters in this data sheet can and do vary in different applications and actual device performance may vary over time. Users should verify actual device performance in their specific applications.

SRR1260 Series - Shielded SMD Power Inductors

BOURNS®

Packaging Specifications

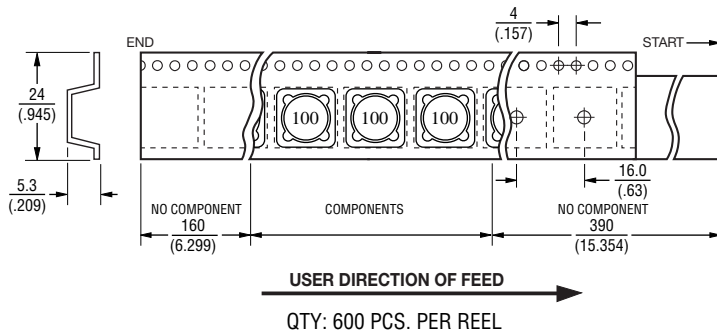
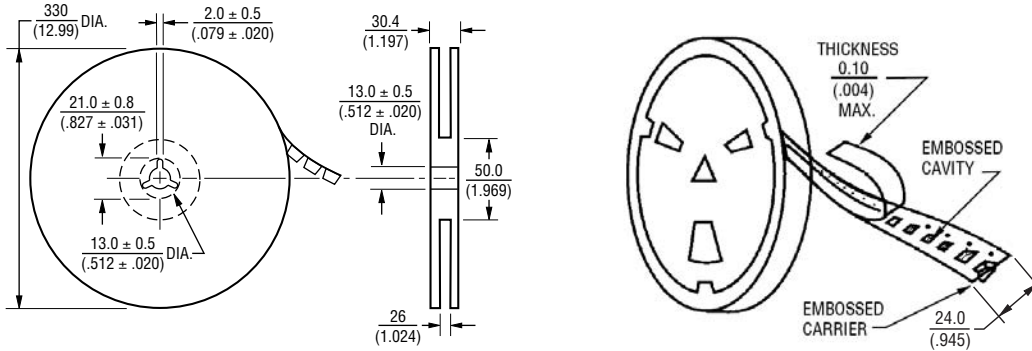

REV. 03/15

Specifications are subject to change without notice.
 The device characteristics and parameters in this data sheet can and do vary in different applications and actual device performance may vary over time.
 Users should verify actual device performance in their specific applications.

		PROD. NAME	Shielded SMD Power Inductor
		PART NO.	SRR1260-470M

■ Inductance VS Current

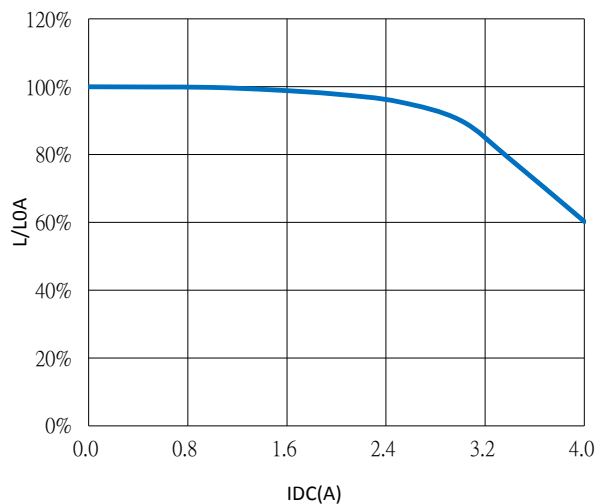

IDC (A)	0	0.5	1.0	1.5	2.0	2.5	3.0	3.4	4.0	
L@25°C	47.68	47.65	47.59	47.23	46.64	45.58	42.96	37.51	28.72	
L/LOA	100%	99.94%	99.81%	99.06%	97.82%	95.60%	90.10%	78.67%	60.23%	

■ Test Condition : 1kHz/1V

■ Test Instrument: WK3260B+WK355B

■ Test Time:

DRAWN	CHECKED	APPROVED	
Leo.Liang 2016/10/27		Nick Chen 2016/10/27	2016/10/27

BOURNS® Reliability Test Report

TITLE : **Temperature Characteristic Test**

PART NO. : SRR1260-470M

Equipment : Humidity&Temp. Champer

Test Equipment : LCR Meter(4194A)

Test condition :

1. Test temperature : -40 °C ~ 125 °C
2. The inductance of each specimen shall be measured 30 to 45 minutes after the chamber temperature has become stable to within $\pm 0.5^{\circ}\text{C}$ at a test temperature.

Specification :

The value of L, shall be meet the specification, as follow:

Part No.	SRR1260-470M
L(μH)	47.0 \pm 20%

Test data :

L(μH) { 1kHz/1V }								
No.	-40°C	-20°C	0°C	25°C	50°C	80°C	100°C	125°C
1	46.97	47.15	47.56	47.98	48.32	48.59	48.72	48.83
2	47.56	47.79	48.22	48.63	48.96	49.22	49.35	49.46
3	47.60	47.73	48.22	48.62	48.95	49.20	49.33	49.44
4	47.32	47.48	47.95	48.39	48.73	49.01	49.16	49.27
5	46.77	46.93	47.35	47.75	48.05	48.30	48.43	48.54
Max	47.60	47.79	48.22	48.63	48.96	49.22	49.35	49.46
Min	46.77	46.93	47.35	47.75	48.05	48.30	48.43	48.54
Average	47.24	47.41	47.86	48.27	48.60	48.86	49.00	49.11
σ_{n-1}	0.362	0.372	0.393	0.393	0.402	0.406	0.409	0.405

Inductance V.S. Temperature curve :

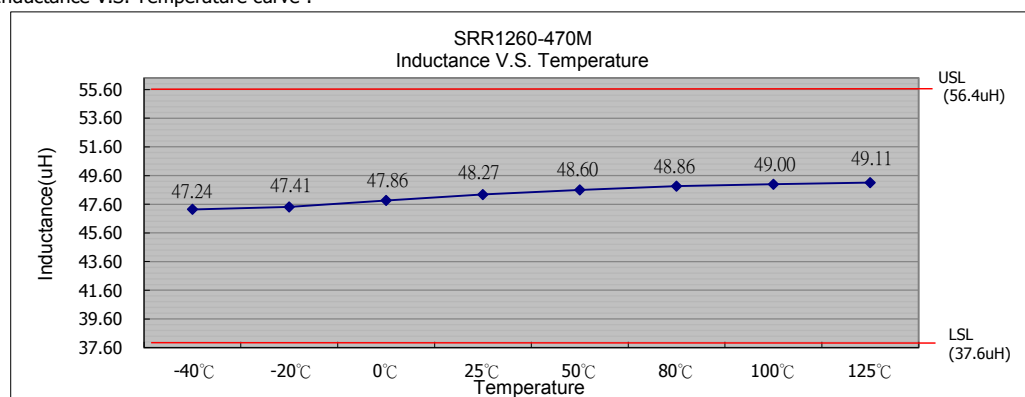

Result :

The result of testing can meet the specification.

DRAWN : Donald Yu
DATE : NOV.10,2016

CHECKED : Jeny Yang
DATE : NOV.10,2016

APPROVED : Fang Lu
DATE : NOV.10,2016