

# LM25017 48-V, 650-mA Constant On-Time Synchronous Buck/Fly-Buck™ Regulator

## 1 Features

- Wide 7.5-V to 48-V input range
- Integrated 650-mA high-side and low-side switches
- No schottky diode required
- Constant on-time control
- No loop compensation required
- Ultra-fast transient response
- Nearly constant operating frequency
- Intelligent peak current limit
- Adjustable output voltage from 1.225 V
- Precision 2% feedback reference
- Frequency adjustable to 1 MHz
- Adjustable undervoltage lockout (UVLO)
- Remote shutdown
- Thermal shutdown
- Create a custom design using the LM25017 with the [WEBENCH® power designer](#)

## 2 Applications

- [Industrial equipment](#)
- [Smart power meters](#)
- [Telecommunication systems](#)
- [Isolated bias supply \(Fly-Buck™\)](#)

## 3 Description

The LM25017 device is a 48-V, 650-mA synchronous step-down regulator with integrated high-side and low-side MOSFETs. The constant on-time (COT) control scheme employed in the LM25017 device requires no loop compensation, provides excellent transient response, and enables very high step-down ratios. The on-time varies inversely with the input voltage resulting in nearly constant frequency over the input voltage range. A high voltage startup regulator provides bias power for internal operation of the IC and for integrated gate drivers.

A peak current limit circuit protects against overload conditions. The undervoltage lockout (UVLO) circuit allows the input undervoltage threshold and hysteresis to be independently programmed. Other protection features include thermal shutdown and bias supply undervoltage lockout ( $V_{CC}$  UVLO).

The LM25017 device is available in WSON-8 and HSOP-8 plastic packages.

### Device Information

| PART NUMBER | PACKAGE  | BODY SIZE (NOM)   |
|-------------|----------|-------------------|
| LM25017     | HSOP (8) | 4.89 mm x 3.90 mm |
|             | WSON (8) | 4.00 mm x 4.00 mm |

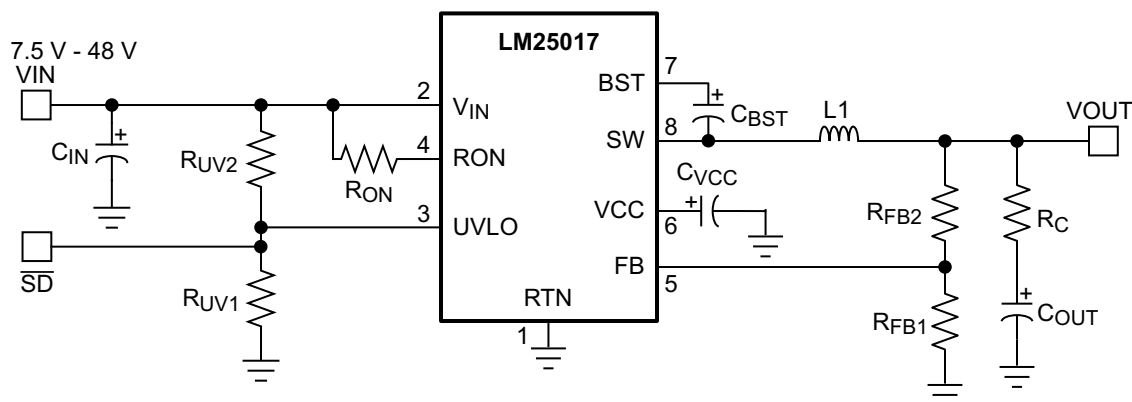

Typical Application Schematic



## Table of Contents

|  |    |  |    |
|--|----|--|----|
| <b>1 Features</b> .....                        | 1  | <b>8 Application and Implementation</b> .....                    | 15 |
| <b>2 Applications</b> .....                    | 1  | 8.1 Application Information.....                                 | 15 |
| <b>3 Description</b> .....                     | 1  | 8.2 Typical Applications.....                                    | 15 |
| <b>4 Revision History</b> .....                | 2  | <b>9 Power Supply Recommendations</b> .....                      | 26 |
| <b>5 Pin Configuration and Functions</b> ..... | 4  | <b>10 Layout</b> .....   | 27 |
| <b>6 Specifications</b> .....                  | 5  | 10.1 Layout Guidelines.....                                      | 27 |
| 6.1 Absolute Maximum Ratings.....              | 5  | 10.2 Layout Example.....   | 27 |
| 6.2 ESD Ratings.....                           | 5  | <b>11 Device and Documentation Support</b> .....                 | 28 |
| 6.3 Recommended Operating Conditions.....      | 5  | 11.1 Device Support.....   | 28 |
| 6.4 Thermal Information.....                   | 5  | 11.2 Documentation Support.....                                  | 28 |
| 6.5 Electrical Characteristics.....            | 6  | 11.3 Receiving Notification of Documentation Updates..           | 28 |
| 6.6 Switching Characteristics.....             | 6  | 11.4 Support Resources.....                                      | 28 |
| 6.7 Typical Characteristics.....               | 7  | 11.5 Trademarks.....   | 28 |
| <b>7 Detailed Description</b> .....            | 9  | 11.6 Electrostatic Discharge Caution.....                        | 28 |
| 7.1 Overview.....                              | 9  | 11.7 Glossary.....   | 29 |
| 7.2 Functional Block Diagram.....              | 9  | <b>12 Mechanical, Packaging, and Orderable Information</b> ..... | 29 |
| 7.3 Feature Description.....                   | 9  |  |    |
| 7.4 Device Functional Modes.....               | 14 |  |    |

## 4 Revision History

| <b>Changes from Revision E (November 2017) to Revision F (May 2021)</b>   | <b>Page</b> |
|---|-------------|
| • Added "Synchronous Fly-Buck" to the title.....  | 1           |
| • Hyperlinked <i>Applications</i> bullets.....  | 1           |
| • Updated the numbering format for tables, figures, and cross-references throughout the document. ....  | 1           |
| <b>Changes from Revision D (December 2014) to Revision E (November 2017)</b>  | <b>Page</b> |
| • Added links for WEBENCH and top nav icon for TI Designs.....  | 1           |
| • Deleted lead temperature and related footnote from Abs Max table.....   | 5           |
| • Changed 14 V to 13 V in <i>V<sub>CC</sub> Regulator</i> section.....  | 10          |
| • Changed 8 to 4 on equation in <i>Input Capacitor</i> section.....   | 17          |
| • Changed 0.34 μF to 0.68 μF in <i>Input Capacitor</i> section.....   | 17          |
| <b>Changes from Revision C (December 2013) to Revision D (October 2014)</b>   | <b>Page</b> |
| • Added <i>Pin Configuration and Functions</i> section, <i>ESD Rating</i> table, <i>Feature Description</i> section, <i>Device Functional Modes</i> , <i>Application and Implementation</i> section, <i>Power Supply Recommendations</i> section, <i>Layout</i> section, <i>Device and Documentation Support</i> section, and <i>Mechanical, Packaging, and Orderable Information</i> section ..... | 1           |
| • Changed VIN voltage in <i>Typical Application</i> .....   | 1           |
| • Changed max operating junction temperature in <i>Recommended Operating Conditions</i> table. ....   | 5           |
| • Updated <i>Thermal Information</i> table with package designators. ....   | 5           |
| • Changed <i>Soft-Start Circuit</i> graphic.....  | 13          |
| • Changed <i>Frequency Selection</i> section, <i>Inductor Selection</i> section, <i>Output Capacitor</i> section, <i>Input Capacitor</i> section, and <i>UVLO Resistors</i> section.....  | 16          |
| <b>Changes from Revision B (December 2013) to Revision C (December 2013)</b>  | <b>Page</b> |
| • Added Thermal Parameters.....   | 5           |

---

**Changes from Revision A (September 2013) to Revision B (December 2013) Page**

---

- Changed formatting throughout document to TI standard..... 1
  - Changed minimum input voltage from 9 V to 7.5 V in *Typical Application* diagram..... 1
  - Changed minimum input voltage from 9 V to 7.5 V in *Pin Descriptions* ..... 4
  - Added Maximum Junction Temperature..... 5
  - Changed minimum input voltage from 9 V to 7.5 V in *Recommended Operating Conditions* ..... 5
- 

**Changes from Revision \* (December 2012) to Revision A (September 2013) Page**

---

- Added SW to RTN (100-ns transient) to *Absolute Maximum Ratings* ..... 5
-

## 5 Pin Configuration and Functions

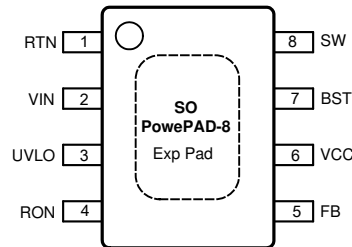

Figure 5-1. 8-Pin HSOP DDA Package Top View

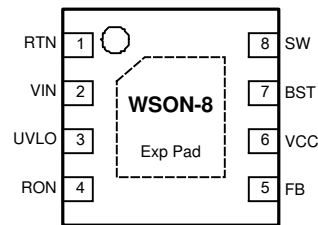

Figure 5-2. 8-Pin WSON NGU Package Top View

Table 5-1. Pin Functions

| PIN |      | I/O | DESCRIPTION   | APPLICATION INFORMATION  |
|-----|------|-----|---|--|
| NO. | NAME |     |   |  |
| 1   | RTN  | —   | Ground  | Ground connection of the integrated circuit.   |
| 2   | VIN  | I   | Input Voltage   | Operating input range is 7.5 V to 48 V.  |
| 3   | UVLO | I   | Input Pin of Undervoltage Comparator  | Resistor divider from $V_{IN}$ to UVLO to GND programs the undervoltage detection threshold. An internal current source is enabled when UVLO is above 1.225 V to provide hysteresis. When UVLO pin is pulled below 0.66 V externally, the regulator is in shutdown mode. |
| 4   | RON  | I   | On-Time Control   | A resistor between this pin and $V_{IN}$ sets the buck switch on-time as a function of $V_{IN}$ . Minimum recommended on-time is 100 ns at max input voltage.  |
| 5   | FB   | I   | Feedback  | This pin is connected to the inverting input of the internal regulation comparator. The regulation level is 1.225 V.   |
| 6   | VCC  | O   | Output from the Internal High Voltage Series Pass Regulator. Regulated at 7.6 V | The internal $V_{CC}$ regulator provides bias supply for the gate drivers and other internal circuitry. A 1.0- $\mu$ F decoupling capacitor is recommended.  |
| 7   | BST  | I   | Bootstrap Capacitor   | An external capacitor is required between the BST and SW pins (0.01- $\mu$ F ceramic). The BST pin capacitor is charged by the $V_{CC}$ regulator through an internal diode when the SW pin is low.  |
| 8   | SW   | O   | Switching Node  | Power switching node. Connect to the output inductor and bootstrap capacitor.  |
| —   | EP   | —   | Exposed Pad   | Exposed pad must be connected to the RTN pin. Solder to the system ground plane on application board for reduced thermal resistance.   |

## 6 Specifications

### 6.1 Absolute Maximum Ratings

|   | MIN <sup>(1) (2)</sup> | MAX                  | UNIT |
|---|------------------------|----------------------|------|
| V <sub>IN</sub> , UVLO to RTN               | -0.3                   | 53                   | V    |
| SW to RTN                                   | -1.5                   | V <sub>IN</sub> +0.3 | V    |
| SW to RTN (100-ns transient)                | -5                     | V <sub>IN</sub> +0.3 | V    |
| BST to V <sub>CC</sub>                      |                        | 53                   | V    |
| BST to SW                                   |                        | 13                   | V    |
| R <sub>ON</sub> to RTN                      | -0.3                   | 53                   | V    |
| V <sub>CC</sub> to RTN                      | -0.3                   | 13                   | V    |
| FB to RTN                                   | -0.3                   | 5                    | V    |
| Maximum junction temperature <sup>(3)</sup> |                        | 150                  | °C   |
| Storage temperature, T <sub>stg</sub>       | -55                    | 150                  | °C   |

- (1) Stresses beyond those listed under *Absolute Maximum Ratings* may cause permanent damage to the device. These are stress ratings only, which do not imply functional operation of the device at these or any other conditions beyond those indicated under *Recommended Operating Conditions*. Exposure to absolute-maximum-rated conditions for extended periods may affect device reliability.
- (2) High junction temperatures degrade operating lifetimes. Operating lifetime is de-rated for junction temperatures greater than 125°C.
- (3) The RTN pin is the GND reference electrically connected to the substrate.

### 6.2 ESD Ratings

|  |  | VALUE | UNIT |
|--|--|-------|------|
| V <sub>(ESD)</sub> Electrostatic discharge | Human-body model (HBM), per ANSI/ESDA/JEDEC JS-001 <sup>(1)</sup>              | ±2000 | V    |
|  | Charged-device model (CDM), per JEDEC specification JESD22-C101 <sup>(2)</sup> | ±750  |      |

- (1) JEDEC document JEP155 states that 500-V HBM allows safe manufacturing with a standard ESD control process.
- (2) JEDEC document JEP157 states that 250-V CDM allows safe manufacturing with a standard ESD control process.

### 6.3 Recommended Operating Conditions

over operating free-air temperature range (unless otherwise noted)<sup>(1)</sup>

|   | MIN | MAX | UNIT |
|---|-----|-----|------|
| V <sub>IN</sub> voltage                       | 7.5 | 48  | V    |
| Operating junction temperature <sup>(2)</sup> | -40 | 125 | °C   |

- (1) *Recommended Operating Conditions* are conditions under the device is intended to be functional. For specifications and test conditions, see [Section 6.5](#).
- (2) High junction temperatures degrade operating lifetimes. Operating lifetime is de-rated for junction temperatures greater than 125°C.

### 6.4 Thermal Information

| THERMAL METRICS <sup>(1)</sup> |  | LM25017 |      | UNIT |
|--------------------------------|--|---------|------|------|
|                                |  | NGU     | DDA  |      |
|                                |  | 8 PINS  |      |      |
| R <sub>θJA</sub>               | Junction-to-ambient thermal resistance             | 41.3    | 41.1 | °C/W |
| R <sub>θJC(top)</sub>          | Junction-to-case (top) thermal resistance          | 34.7    | 37.3 | °C/W |
| R <sub>θJB</sub>               | Junction-to-board thermal resistance               | 19.1    | 30.6 | °C/W |
| ψ <sub>JT</sub>                | Junction-to-top thermal characteristic parameter   | 0.3     | 6.7  | °C/W |
| ψ <sub>JB</sub>                | Junction-to-board thermal characteristic parameter | 19.2    | 24.4 | °C/W |
| R <sub>θJC(bot)</sub>          | Junction-to-case (bottom) thermal resistance       | 3.2     | 2.4  | °C/W |

- (1) For more information about traditional and new thermal metrics, see the *IC Package Thermal Metrics* application report ([SPRA953](#)).

## 6.5 Electrical Characteristics

Typical values correspond to  $T_J = 25^\circ\text{C}$ . Minimum and maximum limits apply over  $-40^\circ\text{C}$  to  $125^\circ\text{C}$  junction temperature range, unless otherwise stated.  $V_{IN} = 48\text{ V}$  unless otherwise stated.  $V_{IN} = 48\text{ V}$  unless otherwise stated. See (1).

| PARAMETER                                     |   | TEST CONDITIONS                                 | MIN  | TYP   | MAX  | UNIT |
|---|---|---|------|-------|------|------|
| <b>V<sub>CC</sub> SUPPLY</b>                  |   |   |      |       |      |      |
| V <sub>CC</sub> Reg                           | V <sub>CC</sub> Regulator Output  | V <sub>IN</sub> = 48 V, I <sub>CC</sub> = 20 mA | 6.25 | 7.6   | 8.55 | V    |
|   | V <sub>CC</sub> Current Limit   | V <sub>IN</sub> = 48 V <sup>(2)</sup>           | 26   |       |      | mA   |
|   | V <sub>CC</sub> Undervoltage Lockout Voltage (V <sub>CC</sub> Increasing) |   | 4.15 | 4.5   | 4.9  | V    |
|   | V <sub>CC</sub> Undervoltage Hysteresis                                   |   |      | 300   |      | mV   |
|   | V <sub>CC</sub> Drop Out Voltage  | V <sub>IN</sub> = 9 V, I <sub>CC</sub> = 20 mA  |      | 2.3   |      | V    |
|   | I <sub>IN</sub> Operating Current   | Non-Switching, FB = 3 V                         |      | 1.75  |      | mA   |
|   | I <sub>IN</sub> Shutdown Current  | UVLO = 0 V                                      |      | 50    | 225  | μA   |
| <b>SWITCH CHARACTERISTICS</b>                 |   |   |      |       |      |      |
|   | Buck Switch R <sub>DS(ON)</sub>   | I <sub>TEST</sub> = 200 mA, BST-SW = 7 V        |      | 0.8   | 1.8  | Ω    |
|   | Synchronous R <sub>DS(ON)</sub>   | I <sub>TEST</sub> = 200 mA                      |      | 0.45  | 1    | Ω    |
|   | Gate Drive UVLO   | V <sub>BST</sub> – V <sub>SW</sub> Rising       | 2.4  | 3     | 3.6  | V    |
|   | Gate Drive UVLO Hysteresis  |   |      | 260   |      | mV   |
| <b>CURRENT LIMIT</b>                          |   |   |      |       |      |      |
|   | Current Limit Threshold   |   | 0.7  | 1.02  | 1.3  | A    |
|   | Current Limit Response Time   | Time to Switch Off                              |      | 150   |      | ns   |
|   | OFF-Time Generator (Test 1)   | FB = 0.1 V, V <sub>IN</sub> = 48 V              |      | 12    |      | μs   |
|   | OFF-Time Generator (Test 2)   | FB = 1.0 V, V <sub>IN</sub> = 48 V              |      | 2.5   |      | μs   |
| <b>REGULATION AND OVERVOLTAGE COMPARATORS</b> |   |   |      |       |      |      |
|   | FB Regulation Level   | Internal Reference Trip Point for Switch ON     | 1.2  | 1.225 | 1.25 | V    |
|   | FB Overvoltage Threshold  | Trip Point for Switch OFF                       |      | 1.62  |      | V    |
|   | FB Bias Current   |   |      | 60    |      | nA   |
| <b>UNDERVOLTAGE SENSING FUNCTION</b>          |   |   |      |       |      |      |
|   | UV Threshold  | UV Rising                                       | 1.19 | 1.225 | 1.26 | V    |
|   | UV Hysteresis Input Current   | UV = 2.5 V                                      | -10  | -20   | -29  | μA   |
|   | Remote Shutdown Threshold   | Voltage at UVLO Falling                         | 0.32 | 0.66  |      | V    |
|   | Remote Shutdown Hysteresis  |   |      | 110   |      | mV   |
| <b>THERMAL SHUTDOWN</b>                       |   |   |      |       |      |      |
| T <sub>sd</sub>                               | Thermal Shutdown Temperature  |   |      | 165   |      | °C   |
|   | Thermal Shutdown Hysteresis   |   |      | 20    |      | °C   |

- (1) All hot and cold limits are specified by correlating the electrical characteristics to process and temperature variations and applying statistical process control.
- (2) V<sub>CC</sub> provides self bias for the internal gate drive and control circuits. Device thermal limitations limit external loading.

## 6.6 Switching Characteristics

Typical values correspond to  $T_J = 25^\circ\text{C}$ . Minimum and maximum limits apply over  $-40^\circ\text{C}$  to  $125^\circ\text{C}$  junction temperature range unless otherwise stated.  $V_{IN} = 48\text{ V}$  unless otherwise stated.

| PARAMETER                |                        | TEST CONDITIONS                                 | MIN  | TYP  | MAX  | UNIT |
|--------------------------|------------------------|---|------|------|------|------|
| <b>ON-TIME GENERATOR</b> |                        |   |      |      |      |      |
|                          | T <sub>ON</sub> Test 1 | V <sub>IN</sub> = 32 V, R <sub>ON</sub> = 100 k | 270  | 350  | 460  | ns   |
|                          | T <sub>ON</sub> Test 2 | V <sub>IN</sub> = 48 V, R <sub>ON</sub> = 100 k | 188  | 250  | 336  | ns   |
|                          | T <sub>ON</sub> Test 4 | V <sub>IN</sub> = 10 V, R <sub>ON</sub> = 250 k | 1880 | 3200 | 4425 | ns   |
| <b>MINIMUM OFF-TIME</b>  |                        |   |      |      |      |      |

Typical values correspond to  $T_J = 25^\circ\text{C}$ . Minimum and maximum limits apply over  $-40^\circ\text{C}$  to  $125^\circ\text{C}$  junction temperature range unless otherwise stated.  $V_{IN} = 48\text{ V}$  unless otherwise stated.

| PARAMETER         | TEST CONDITIONS | MIN | TYP | MAX | UNIT |
|-------------------|-----------------|-----|-----|-----|------|
| Minimum Off-Timer | FB = 0 V        |     | 144 |     | ns   |

### 6.7 Typical Characteristics

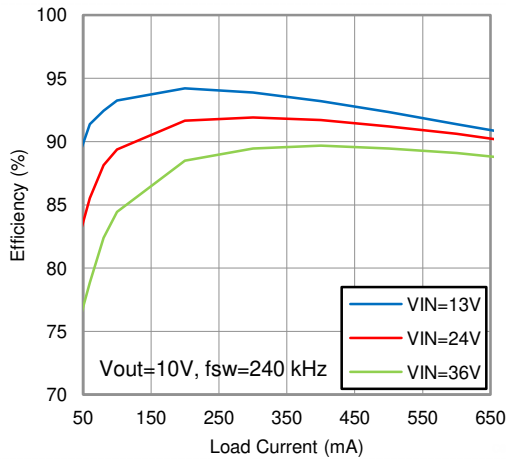

**Figure 6-1. Efficiency at 200 kHz, 10 V**

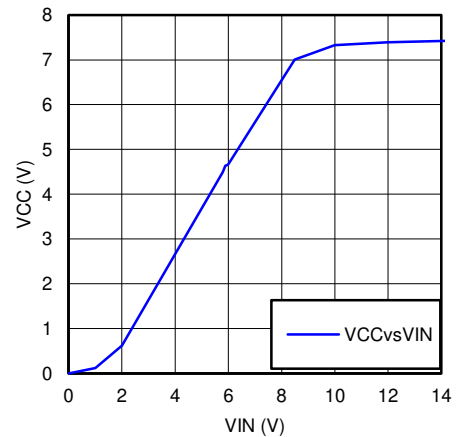

**Figure 6-2.  $V_{CC}$  vs  $V_{IN}$**

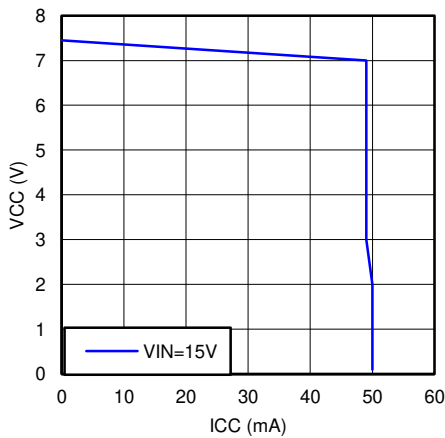

**Figure 6-3.  $V_{CC}$  vs  $I_{CC}$**

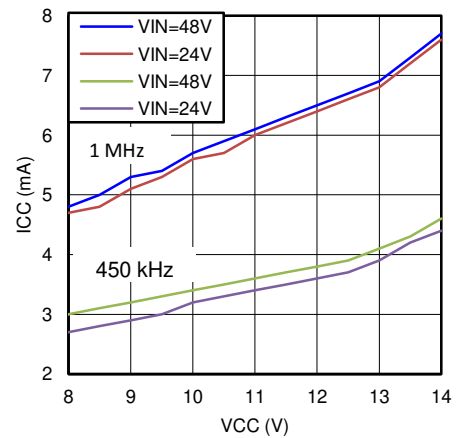

**Figure 6-4.  $I_{CC}$  vs External  $V_{CC}$**

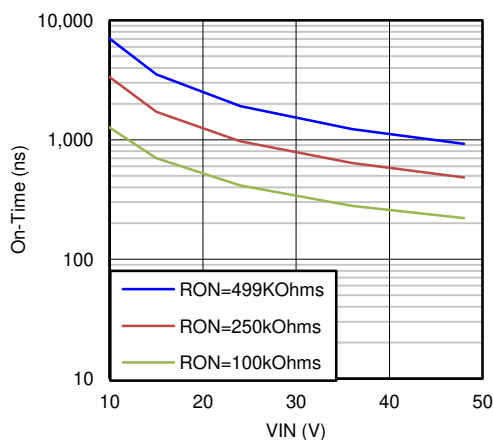

**Figure 6-5.  $T_{ON}$  vs  $V_{IN}$  and  $R_{ON}$**

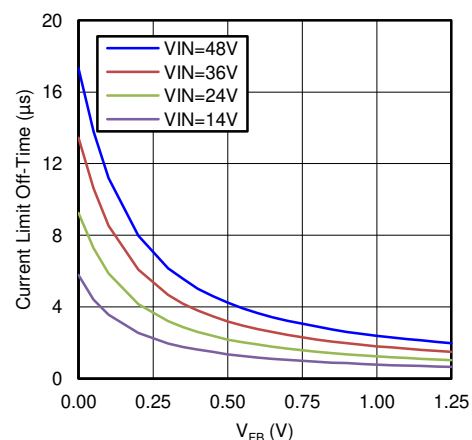

**Figure 6-6.  $T_{OFF} (I_{LIM})$  vs  $V_{FB}$  and  $V_{IN}$**

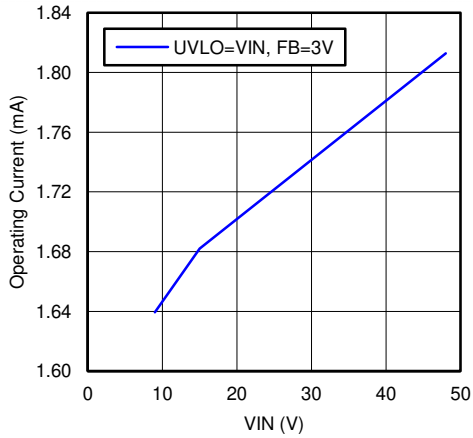

Figure 6-7.  $I_{IN}$  vs  $V_{IN}$  (Operating, Non-Switching)

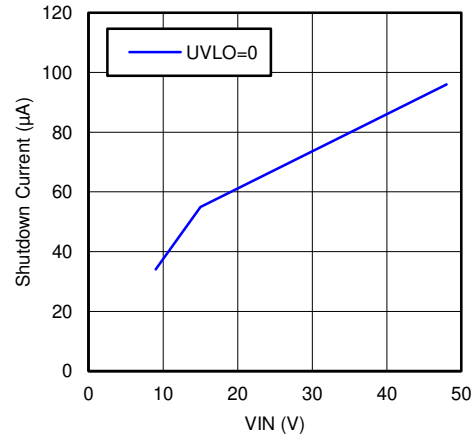

Figure 6-8.  $I_{IN}$  vs  $V_{IN}$  (Shutdown)

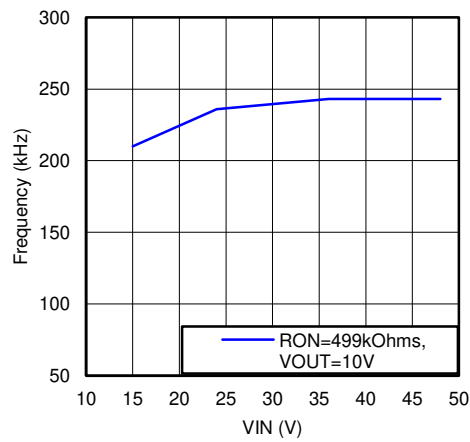

Figure 6-9. Switching Frequency vs  $V_{IN}$



## 7 Detailed Description

### 7.1 Overview

The LM25017 step-down switching regulator features all the functions needed to implement a low cost, efficient, buck converter capable of supplying up to 650 mA to the load. This high voltage regulator contains 48-V, N-channel buck and synchronous switches, is easy to implement, and is provided in thermally enhanced SO PowerPAD-8 and WSON-8 packages. The regulator operation is based on a constant on-time control scheme using an on-time inversely proportional to  $V_{IN}$ . This control scheme does not require loop compensation. The current limit is implemented with a forced off-time inversely proportional to  $V_{OUT}$ . This scheme ensures short circuit protection while providing minimum fold-back.

The LM25017 device can be applied in numerous applications to efficiently regulate down higher voltages. This regulator is well suited for 12-V and 24-V rails. Protection features include: thermal shutdown, Undervoltage Lockout (UVLO), minimum forced off-time, and an intelligent current limit.

### 7.2 Functional Block Diagram

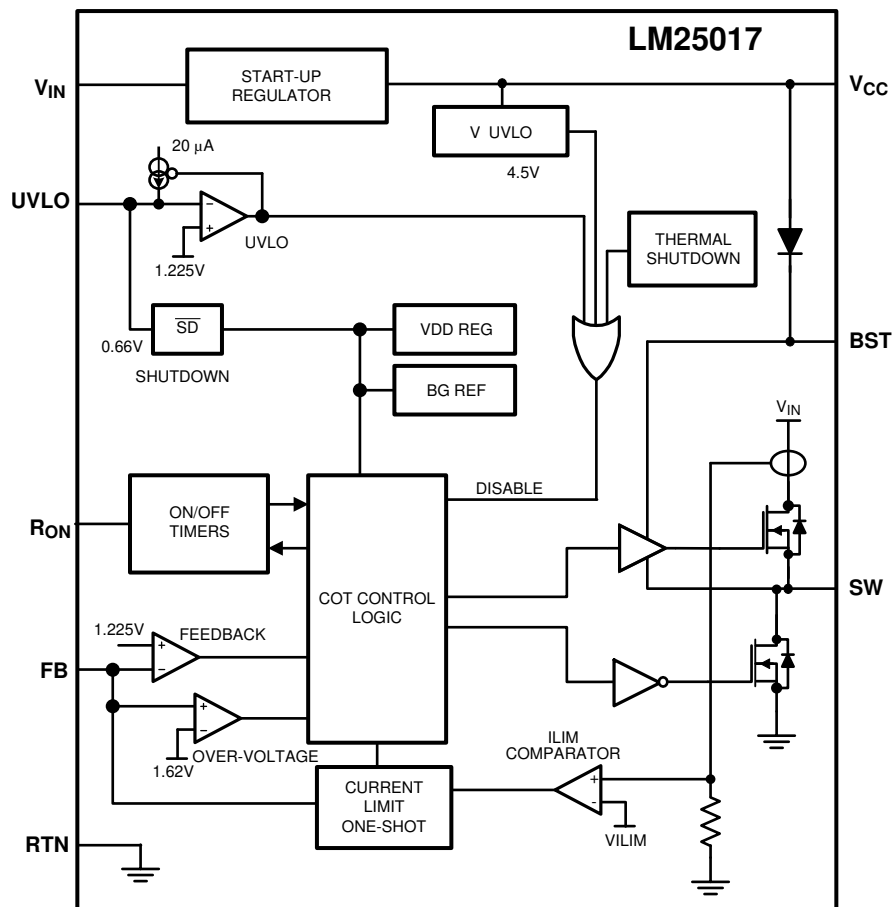

### 7.3 Feature Description

#### 7.3.1 Control Overview

The LM25017 buck regulator employs a control principle based on a comparator and a one-shot on-timer, with the output voltage feedback (FB) compared to an internal reference (1.225 V). If the FB voltage is below the reference the internal buck switch is turned on for the one-shot timer period, which is a function of the input voltage and the programming resistor ( $R_{ON}$ ). Following the on-time the switch remains off until the FB voltage falls below the reference, but never before the minimum off-time forced by the minimum off-time one-shot timer. When the FB pin voltage falls below the reference and the minimum off-time one-shot period expires, the buck

switch is turned on for another on-time one-shot period. This will continue until regulation is achieved and the FB voltage is approximately equal to 1.225 V (typ).

In a synchronous buck converter, the low side (sync) FET is 'on' when the high side (buck) FET is 'off'. The inductor current ramps up when the high side switch is 'on' and ramps down when the high side switch is 'off'. There is no diode emulation feature in this IC, and therefore, the inductor current may ramp in the negative direction at light load. This causes the converter to operate in continuous conduction mode (CCM) regardless of the output loading. The operating frequency remains relatively constant with load and line variations. The operating frequency can be calculated as shown in [Equation 1](#).

$$f_{\text{SW}} = \frac{V_{\text{OUT}}}{K \times R_{\text{ON}}} \quad (1)$$

where

- $K = 9 \times 10^{-11}$

The output voltage ( $V_{\text{OUT}}$ ) is set by two external resistors ( $R_{\text{FB1}}$ ,  $R_{\text{FB2}}$ ). The regulated output voltage is calculated as shown in [Equation 2](#).

$$V_{\text{OUT}} = 1.225 \text{ V} \times \frac{R_{\text{FB2}} + R_{\text{FB1}}}{R_{\text{FB1}}} \quad (2)$$

This regulator regulates the output voltage based on ripple voltage at the feedback input, requiring a minimum amount of ESR for the output capacitor ( $C_{\text{OUT}}$ ). A minimum of 25-mV ripple voltage at the feedback pin (FB) is required for the LM25017 device. In cases where the capacitor ESR is too small, additional series resistance may be required ( $R_{\text{C}}$  in [Figure 7-1](#)).

For applications where lower output voltage ripple is required, the output can be taken directly from a low ESR output capacitor, as shown in [Figure 7-1](#). However,  $R_{\text{C}}$  slightly degrades the load regulation.

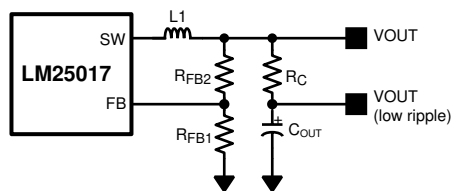

**Figure 7-1. Low Ripple Output Configuration**

### 7.3.2 $V_{\text{CC}}$ Regulator

The LM25017 device contains an internal high-voltage linear regulator with a nominal output of 7.6 V. The input pin ( $V_{\text{IN}}$ ) can be connected directly to the line voltages up to 48 V. The  $V_{\text{CC}}$  regulator is internally current limited to 30 mA. The regulator sources current into the external capacitor at  $V_{\text{CC}}$ . This regulator supplies current to internal circuit blocks including the synchronous MOSFET driver and the logic circuits. When the voltage on the  $V_{\text{CC}}$  pin reaches the undervoltage lockout ( $V_{\text{CC}}$  UVLO) threshold of 4.5 V, the IC is enabled.

An internal diode connected from  $V_{\text{CC}}$  to the BST pin replenishes the charge in the gate drive bootstrap capacitor when SW pin is low.

At high-input voltages, the power dissipated in the high voltage regulator is significant and can limit the overall achievable output power. As an example, with the input at 48 V and switching at high frequency, the  $V_{\text{CC}}$  regulator may supply up to 7 mA of current resulting in  $48 \text{ V} \times 7 \text{ mA} = 336 \text{ mW}$  of power dissipation. If the  $V_{\text{CC}}$  voltage is driven externally by an alternate voltage source between 8.55 V and 13 V, the internal regulator is disabled. This reduces the power dissipation in the IC.

### 7.3.3 Regulation Comparator

The feedback voltage at FB is compared to an internal 1.225-V reference. In normal operation, when the output voltage is in regulation, an on-time period is initiated when the voltage at FB falls below 1.225 V. The high side

switch will stay on for the on-time, causing the FB voltage to rise above 1.225 V. After the on-time period, the high side switch will stay off until the FB voltage again falls below 1.225 V. During start up, the FB voltage will be below 1.225 V at the end of each on-time, causing the high side switch to turn on immediately after the minimum forced off-time of 144 ns. The high side switch can be turned off before the on-time is over if the peak current in the inductor reaches the current limit threshold.

### 7.3.4 Overvoltage Comparator

The feedback voltage at FB is compared to an internal 1.62-V reference. If the voltage at FB rises above 1.62 V the on-time pulse is immediately terminated. This condition can occur if the input voltage and/or the output load changes suddenly. The high side switch will not turn on again until the voltage at FB falls below 1.225 V.

### 7.3.5 On-Time Generator

The on-time for the LM25017 device is determined by the  $R_{ON}$  resistor and is inversely proportional to the input voltage ( $V_{IN}$ ), resulting in a nearly constant frequency as  $V_{IN}$  is varied over the operating range. The on-time for the LM25017 can be calculated using [Equation 3](#).

$$T_{ON} = \frac{10^{-10} \times R_{ON}}{V_{IN}} \quad (3)$$

See [Figure 6-5](#).  $R_{ON}$  should be selected for a minimum on-time (at maximum  $V_{IN}$ ) greater than 100 ns for proper operation. This requirement limits the maximum switching frequency for high  $V_{IN}$ .

### 7.3.6 Current Limit

The LM25017 device contains an intelligent current limit off-timer. If the current in the buck switch exceeds 1.02 A, the present cycle is immediately terminated, and a non-resetable off-timer is initiated. The length of the off-time is controlled by the FB voltage and the input voltage  $V_{IN}$ . As an example, when  $FB = 0$  V and  $V_{IN} = 48$  V, the maximum off-time is set to 16  $\mu$ s. This condition occurs when the output is shorted and during the initial part of start-up. This  $V_{IN}$  dependent off-time ensures safe short circuit operation up to the maximum input voltage of 48 V.

In cases of overload where the FB voltage is above zero volts (not a short circuit) the current limit off-time is reduced. Reducing the off-time during less severe overloads reduces the amount of fold-back, recovery time, and start-up time. The off-time is calculated as shown in [Equation 4](#).

$$T_{OFF(ILIM)} = \frac{0.07 \times V_{IN}}{V_{FB} + 0.2V} \mu\text{s} \quad (4)$$

The current limit protection feature is peak limited. The maximum average output current will be less than the peak.

### 7.3.7 N-Channel Buck Switch and Driver

The LM25017 device integrates an N-Channel Buck switch and associated floating high-voltage gate driver. The gate driver circuit works in conjunction with an external bootstrap capacitor and an internal high-voltage diode. A 0.01- $\mu$ F ceramic capacitor connected between the BST pin and the SW pin provides the voltage to the driver during the on-time. During each off-time, the SW pin is at approximately 0 V, and the bootstrap capacitor charges from  $V_{CC}$  through the internal diode. The minimum off-timer, set to 144 ns, ensures a minimum time each cycle to recharge the bootstrap capacitor.

### 7.3.8 Synchronous Rectifier

The LM25017 device provides an internal synchronous N-Channel MOSFET rectifier. This MOSFET provides a path for the inductor current to flow when the high-side MOSFET is turned off.

The synchronous rectifier has no diode emulation mode, and is designed to keep the regulator in continuous conduction mode even with light loads which would otherwise result in discontinuous operation.

### 7.3.9 Undervoltage Detector

The LM25017 device contains a dual-level undervoltage lockout (UVLO) circuit. A summary of threshold voltages and operational states is provided in [Section 7.4](#). When the UVLO pin voltage is below 0.66 V, the regulator is in a low current shutdown mode. When the UVLO pin voltage is greater than 0.66 V but less than 1.225 V, the regulator is in standby mode. In standby mode the  $V_{CC}$  bias regulator is active while the regulator output is disabled. When the  $V_{CC}$  pin exceeds the  $V_{CC}$  undervoltage threshold and the UVLO pin voltage is greater than 1.225 V, normal operation begins. An external set-point voltage divider from  $V_{IN}$  to GND can be used to set the minimum operating voltage of the regulator.

UVLO hysteresis is accomplished with an internal 20- $\mu$ A current source that is switched on or off into the impedance of the set-point divider. When the UVLO threshold is exceeded, the current source is activated to quickly raise the voltage at the UVLO pin. The hysteresis is equal to the value of this current times the resistance  $R_{UV2}$ .

If the UVLO pin is connected directly to the  $V_{IN}$  pin, the regulator will begin operation once the  $V_{CC}$  undervoltage is satisfied.

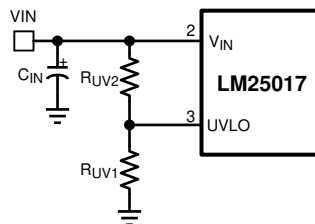

**Figure 7-2. UVLO Resistor Setting**

### 7.3.10 Thermal Protection

The LM25017 device should be operated so the junction temperature does not exceed 150°C during normal operation. An internal Thermal Shutdown circuit is provided to protect the LM25017 in the event of a higher than normal junction temperature. When activated, typically at 165°C, the regulator is forced into a low power reset state, disabling the buck switch and the  $V_{CC}$  regulator. This feature prevents catastrophic failures from accidental device overheating. When the junction temperature falls below 145°C (typical hysteresis = 20°C), the  $V_{CC}$  regulator is enabled, and normal operation is resumed.

### 7.3.11 Ripple Configuration

LM25017 uses Constant-On-Time (COT) control in which the on-time is terminated by an on-timer and the off-time is terminated by the feedback voltage ( $V_{FB}$ ) falling below the reference voltage ( $V_{REF}$ ). Therefore, for stable operation, the feedback voltage must decrease monotonically, in phase with the inductor current during the off-time. Furthermore, this change in feedback voltage ( $V_{FB}$ ) during off-time must be larger than any noise component present at the feedback node.

[Table 7-1](#) shows three different methods for generating appropriate voltage ripple at the feedback node. Type 1 and Type 2 ripple circuits couple the ripple at the output of the converter to the feedback node (FB). The output voltage ripple has two components:

1. Capacitive ripple caused by the inductor current ripple charging/discharging the output capacitor.
2. Resistive ripple caused by the inductor current ripple flowing through the ESR of the output capacitor.

The capacitive ripple is not in phase with the inductor current. As a result, the capacitive ripple does not decrease monotonically during the off-time. The resistive ripple is in phase with the inductor current and

decreases monotonically during the off-time. The resistive ripple must exceed the capacitive ripple at the output node ( $V_{OUT}$ ) for stable operation. If this condition is not satisfied unstable switching behavior is observed in COT converters, with multiple on-time bursts in close succession followed by a long off-time.

Type 3 ripple method uses  $R_r$  and  $C_r$  and the switch node (SW) voltage to generate a triangular ramp. This triangular ramp is ac coupled using  $C_{ac}$  to the feedback node (FB). Since this circuit does not use the output voltage ripple, it is ideally suited for applications where low output voltage ripple is required. See *AN-1481 Controlling Output Ripple and Achieving ESR Independence in Constant On-Time (COT) Regulator Designs (SNVA166)* for more details for each ripple generation method.

### Ripple Configuration

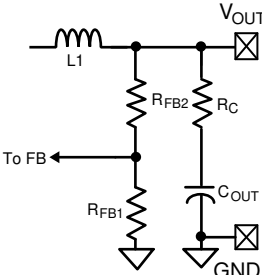
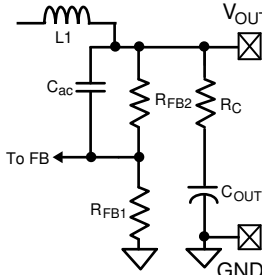
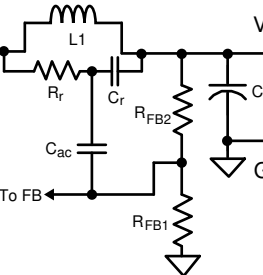
| TYPE 1<br>LOWEST COST CONFIGURATION  | TYPE 2<br>REDUCED RIPPLE CONFIGURATION   | TYPE 3<br>MINIMUM RIPPLE CONFIGURATION  |
|--|--|---|
|         |                         |    |
| $R_C \geq \frac{25 \text{ mV}}{\Delta I_{L(\text{MIN})}} \times \frac{V_{OUT}}{V_{REF}}$ | $C \geq \frac{5}{f_{sw} (R_{FB2}    R_{FB1})}$ $R_C \geq \frac{25 \text{ mV}}{\Delta I_{L(\text{MIN})}}$ | $R_r C_r \leq \frac{(V_{IN(\text{MIN})} - V_{OUT}) \times T_{ON}}{25 \text{ mV}}$ <p> <math>C_r = 3300 \text{ pF}</math><br/> <math>C_{ac} = 100 \text{ nF}</math> </p> |

### 7.3.12 Soft-Start

A soft-start feature can be implemented with the LM25017 device using an external circuit. As shown in [Figure 7-3](#), the soft-start circuit consists of one capacitor,  $C_1$ , two resistors,  $R_1$  and  $R_2$ , and a diode,  $D$ . During the initial start-up, the VCC voltage is established prior to the  $V_{OUT}$  voltage. Capacitor  $C_1$  is discharged and diode  $D$  is thereby forward biased to pull up the FB pin voltage. The FB voltage exceeds the reference voltage (1.225 V) and switching is therefore disabled. As capacitor  $C_1$  charges, the voltage at node B gradually decreases and switching commences.  $V_{OUT}$  will gradually rise to maintain the FB voltage at the reference voltage. Once the voltage at node B is less than a diode drop above the FB voltage, the soft-start sequence is finished and  $D$  is reverse biased.

During the initial part of the start-up, the FB voltage can be approximated as shown in [Equation 5](#).

$$V_{FB} = (V_{CC} - V_D) \times \frac{R_{FB1} \times R_{FB2}}{R_2 \times (R_{FB1} + R_{FB2}) + R_{FB1} \times R_{FB2}} \quad (8)$$

C1 is charged after the first start up. Diode D1 is optional and can be added to discharge C1 when the input voltage experiences a momentary drop to initialize the soft-start sequence.

To achieve the desired soft start, the following design guidance is recommended:

- R<sub>2</sub> is selected so that V<sub>FB</sub> is higher than 1.225 V for a V<sub>CC</sub> of 4.5 V, but is lower than 5 V when V<sub>CC</sub> is 8.55 V. If an external V<sub>CC</sub> is used, V<sub>FB</sub> should not exceed 5 V at maximum V<sub>CC</sub>.
- C<sub>1</sub> is selected to achieve the desired start-up time which can be determined from [Equation 6](#).

$$t_S = C_1 \times \left( R_2 + \frac{R_{FB1} \times R_{FB2}}{R_{FB1} + R_{FB2}} \right) \quad (9)$$

- R<sub>1</sub> is used to maintain the node B voltage at zero after the soft start is finished. A value larger than the feedback resistor divider is preferred. Note that the effect of resistor R1 is ignored in [Equation 5](#).

Based on the schematic shown in [Figure 7-3](#), selecting C<sub>1</sub> = 1 uF, R<sub>2</sub> = 1 kΩ, R<sub>1</sub> = 30 kΩ results in a soft-start time of about 2 ms.

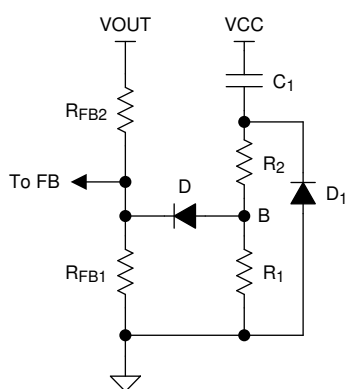

**Figure 7-3. Soft-Start Circuit**

## 7.4 Device Functional Modes

The UVLO pin controls the operating mode of the LM25017 device (see [Table 7-1](#) for the detailed functional states).

**Table 7-1. UVLO Mode**

| UVLO             | V <sub>CC</sub>         | MODE      | DESCRIPTION  |
|------------------|-------------------------|-----------|--|
| < 0.66 V         | Disabled                | Shutdown  | V <sub>CC</sub> regulator disabled.<br>Switching disabled. |
| 0.66 V – 1.225 V | Enabled                 | Standby   | V <sub>CC</sub> regulator enabled<br>Switching disabled.   |
| > 1.225 V        | V <sub>CC</sub> < 4.5 V | Standby   | V <sub>CC</sub> regulator enabled.<br>Switching disabled.  |
|                  | V <sub>CC</sub> > 4.5 V | Operating | V <sub>CC</sub> enabled.<br>Switching enabled.             |

## 8 Application and Implementation

### Note

Information in the following applications sections is not part of the TI component specification, and TI does not warrant its accuracy or completeness. TI's customers are responsible for determining suitability of components for their purposes, as well as validating and testing their design implementation to confirm system functionality.

### 8.1 Application Information

The LM25017 device is step-down dc-to-dc converter. The device is typically used to convert a higher dc voltage to a lower dc voltage with a maximum available output current of 650 mA. Use the following design procedure to select component values for the LM25017 device. Alternately, use the WEBENCH® software to generate a complete design. The WEBENCH™ software uses an iterative design procedure and accesses a comprehensive database of components when generating a design. This section presents a simplified discussion of the design process.

### 8.2 Typical Applications

#### 8.2.1 Application Circuit: 12.5-V to 48-V Input and 10-V, 650-mA Output Buck Converter

The application schematic of a buck supply is shown in [Figure 8-1](#). For output voltage ( $V_{OUT}$ ) above the maximum regulation threshold of  $V_{CC}$  (8.55 V, see [Section 6.5](#)), the  $V_{CC}$  pin can be connected to  $V_{OUT}$  through a diode (D2), for higher efficiency and lower power dissipation in the IC.

The design example shown in [Figure 8-1](#) uses equations from the [Section 7.3](#) section with component names provided in the Typical Application . Corresponding component designators from [Typical Application Schematic](#) are also provided for each selected value.

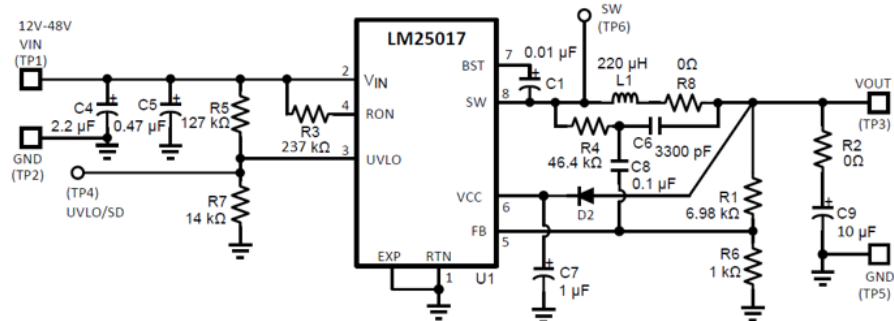

Figure 8-1. Final Schematic for 12.5-V to 48-V Input, and 10-V, 650-mA Output Buck Converter

#### 8.2.1.1 Design Requirements

Selection of external components is illustrated through a design example. The design example specifications are shown in [Table 8-1](#).

Table 8-1. Buck Converter Design Specifications

| DESIGN PARAMETERS           | VALUE          |
|-----------------------------|----------------|
| Input Range                 | 12.5 V to 48 V |
| Output Voltage              | 10 V           |
| Maximum Output Current      | 650 mA         |
| Nominal Switching Frequency | ≈ 480 kHz      |

### 8.2.1.2 Detailed Design Procedure

#### 8.2.1.2.1 Custom Design With WEBENCH® Tools

[Click here](#) to create a custom design using the LM25017 device with the WEBENCH® Power Designer.

1. Start by entering the input voltage ( $V_{IN}$ ), output voltage ( $V_{OUT}$ ), and output current ( $I_{OUT}$ ) requirements.
2. Optimize the design for key parameters such as efficiency, footprint, and cost using the optimizer dial.
3. Compare the generated design with other possible solutions from Texas Instruments.

The WEBENCH Power Designer provides a customized schematic along with a list of materials with real-time pricing and component availability.

In most cases, these actions are available:

- Run electrical simulations to see important waveforms and circuit performance
- Run thermal simulations to understand board thermal performance
- Export customized schematic and layout into popular CAD formats
- Print PDF reports for the design, and share the design with colleagues

Get more information about WEBENCH tools at [www.ti.com/WEBENCH](http://www.ti.com/WEBENCH).

#### 8.2.1.2.2 RFB1, RFB2

$V_{OUT} = V_{FB} \times (R_{FB2} / R_{FB1} + 1)$ , and because  $V_{FB} = 1.225$  V, the ratio of  $R_{FB2}$  to  $R_{FB1}$  calculates as 7:1. Standard values are chosen with  $R_{FB2} = R1 = 6.98$  k $\Omega$  and  $R_{FB1} = R6 = 1.00$  k $\Omega$  are chosen. Other values could be used as long as the 7:1 ratio is maintained.

#### 8.2.1.2.3 Frequency Selection

At the minimum input voltage, the maximum switching frequency of LM25017 is restricted by the forced minimum off-time ( $T_{OFF(MIN)}$ ) as shown in [Equation 7](#).

$$f_{SW(MAX)} = \frac{1 - D_{MAX}}{T_{OFF(MIN)}} = \frac{1 - 10/12.5}{200 \text{ ns}} = 1 \text{ MHz} \quad (10)$$

Similarly, at maximum input voltage, the maximum switching frequency of LM25017 is restricted by the minimum  $T_{ON}$  as shown in [Equation 8](#).

$$f_{SW(MAX)} = \frac{D_{MIN}}{T_{ON(MIN)}} = \frac{10/48}{100 \text{ ns}} = 2.1 \text{ MHz} \quad (11)$$

Resistor  $R_{ON}$  sets the nominal switching frequency based on [Equation 9](#).

$$f_{SW} = \frac{V_{OUT}}{K \times R_{ON}} \quad (12)$$

where

- $K = 9 \times 10^{-11}$

Operation at high switching frequency results in lower efficiency while providing the smallest solution. For this example, 480 kHz was selected, resulting in  $R_{ON} = 231.5$  k $\Omega$ . Selecting a standard value for  $R_{ON} = R3 = 237$  k $\Omega$ .

#### 8.2.1.2.4 Inductor Selection

The minimum inductance is selected to limit the output ripple to 15 to 40 percent of the maximum load current. In addition, the peak inductor current at maximum load should be smaller than the minimum current limit as given in [Section 6.5](#). The inductor current ripple is shown in [Equation 10](#).

$$\Delta I_L = \frac{V_{IN} - V_{OUT}}{L1 \times f_{SW}} \times \frac{V_{OUT}}{V_{IN}} \quad (13)$$



The maximum ripple is observed at maximum input voltage. To achieve the required output current of 650 mA without exceeding the peak current limit threshold, low ripple current is required. Substituting  $V_{IN} = 48\text{ V}$  and  $\Delta I_L = 15\text{ percent} \times I_{OUT(\text{max})}$  results in  $L1 = 169\text{ }\mu\text{H}$ . The higher value of  $220\text{ }\mu\text{H}$  is chosen. The peak-to-peak minimum and maximum inductor current ripples of 19 mA and 75 mA at the minimum and maximum input voltages respectively. The peak inductor and switch current is shown in [Equation 11](#).

$$I_{L(\text{peak})} = I_{OUT} + \frac{\Delta I_L(\text{max})}{2} = 688\text{ mA} \quad (14)$$

688 mA is smaller than the minimum current limit threshold, which is 700 mA. The selected inductor should be able to operate at the maximum current limit of 1.3 A, during startup and overload conditions without saturating.

#### 8.2.1.2.5 Output Capacitor

The output capacitor is selected to minimize the capacitive ripple across it. The maximum ripple is observed at maximum input voltage and is shown in [Equation 12](#).

$$C_{OUT} = \frac{\Delta I_L}{8 \times f_{sw} \times \Delta V_{\text{ripple}}} \quad (15)$$

where

- $\Delta V_{\text{ripple}}$  is the voltage ripple across the capacitor.

Substituting  $\Delta V_{\text{ripple}} = 5\text{ mV}$  gives  $C_{OUT} = 3.9\text{ }\mu\text{F}$ . A 10- $\mu\text{F}$  standard value is selected for  $C_{OUT} = C9$ . An X5R or X7R type capacitor with a voltage rating 16 V or higher should be selected.

#### 8.2.1.2.6 Type III Ripple Circuit

Type III ripple circuit as described in [Section 7.3.11](#) is chosen for this example. For a constant on time converter to be stable, the injected in-phase ripple should be larger than the capacitive ripple on  $C_{OUT}$ .

Using type III ripple circuit equations, the target ripple should be greater than the capacitive ripple generated at the primary output.

$$C_r = C6 = 3300\text{ pF}$$

$$C_{ac} = C8 = 100\text{ nF}$$

$$R_r \leq \frac{(V_{IN(\text{MIN})} - V_{OUT}) \times T_{ON(\text{VINMIN})}}{(25\text{mV} \times C_r)} \quad (16)$$

For  $T_{ON}$ , refer to [Equation 3](#).

Ripple resistor  $R_r$  is calculated to be 57.6 k $\Omega$ . This value provides the minimum ripple for stable operation. A smaller resistance should be selected to allow for variations in  $T_{ON}$ ,  $C_{OUT}$ , and other components.  $R_r = R4 = 46.4\text{ k}\Omega$  is selected for this example application.

#### 8.2.1.2.7 V<sub>CC</sub> and Bootstrap Capacitor

The  $V_{CC}$  capacitor provides charge to bootstrap capacitor as well as internal circuitry and low side gate driver. The bootstrap capacitor provides charge to high side gate driver. The recommended value for  $C_{V_{CC}} = C7$  is 1  $\mu\text{F}$ . A good value for  $C_{BST} = C1$  is 0.01  $\mu\text{F}$ .

#### 8.2.1.2.8 Input Capacitor

The input capacitor should be large enough to limit the input voltage ripple and can be calculated using [Equation 14](#).

$$C_{IN} \geq \frac{I_{OUT(\text{MAX})}}{4 \times f_{sw} \times \Delta V_{IN}} \quad (17)$$

Choosing a  $\Delta V_{IN} = 0.5 \text{ V}$  gives a minimum  $C_{IN} = 0.68 \text{ }\mu\text{F}$ . A standard value of  $2.2 \text{ }\mu\text{F}$  is selected for  $C_{IN} = C4$ . The input capacitor should be rated for the maximum input voltage under all conditions. A 50-V, X7R dielectric should be selected for this design.

The input capacitor should be placed directly across  $V_{IN}$  and RTN (pin 2 and 1) of the IC. If it is not possible to place all of the input capacitor close to the IC, a  $0.47\text{-}\mu\text{F}$  capacitor should be placed near the IC to provide a bypass path for the high-frequency component of the switching current. This helps limit the switching noise.

#### 8.2.1.2.9 UVLO Resistors

The UVLO resistors  $R_{FB1}$  and  $R_{FB2}$  set the UVLO threshold and hysteresis according to the following relationship between [Equation 15](#) and [Equation 16](#).

$$V_{IN(\text{HYS})} = I_{\text{HYS}} \times R_{\text{UV2}} \quad (18)$$

$$V_{IN(\text{UVLO, rising})} = 1.225\text{V} \times \left( \frac{R_{\text{UV2}}}{R_{\text{UV1}}} + 1 \right) \quad (19)$$

where

- $I_{\text{HYS}} = 20 \text{ }\mu\text{A}$

Setting UVLO hysteresis of  $2.5 \text{ V}$  and UVLO rising threshold of  $12 \text{ V}$  results in  $R_{\text{UV1}} = 14.53 \text{ k}\Omega$  and  $R_{\text{UV2}} = 125 \text{ k}\Omega$ . Selecting a standard value of  $R_{\text{UV1}} = R7 = 14 \text{ k}\Omega$  and  $R_{\text{UV2}} = R5 = 127 \text{ k}\Omega$  results in UVLO thresholds and hysteresis of  $12.5 \text{ V}$  to  $2.5 \text{ V}$  respectively.

### 8.2.1.3 Application Curves

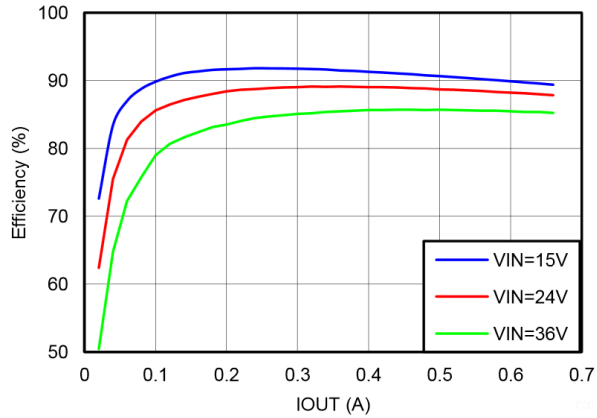

Figure 8-2. Efficiency vs Load Current

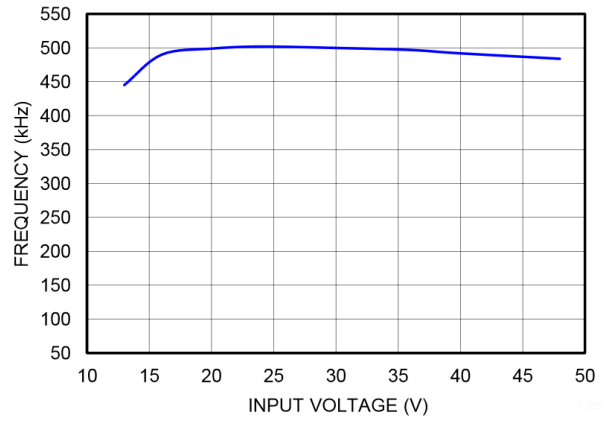

Figure 8-3. Frequency vs Input Voltage

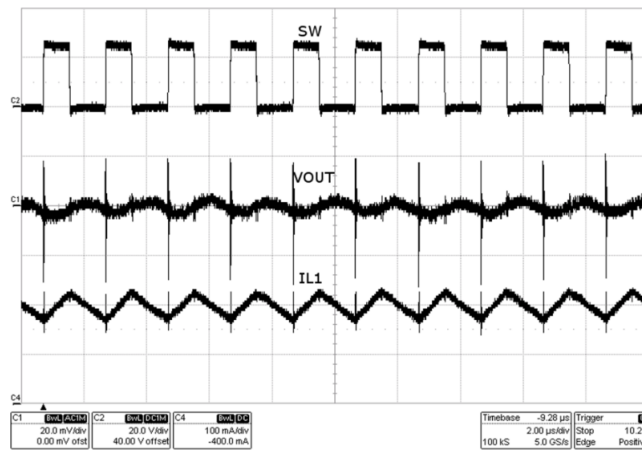

Figure 8-4. Typical Switching Waveform ( $V_{IN} = 24\text{ V}$ ,  $I_{OUT} = 200\text{ mA}$ )

## 8.2.2 Typical Isolated DC-DC Converter Using LM25017

An isolated supply using LM25017 is shown in Figure 8-5. Inductor (L) in a typical buck circuit is replaced with a coupled inductor (X1). A diode (D1) is used to rectify the voltage on a secondary output. The nominal voltage at the secondary output ( $V_{OUT2}$ ) is given by Equation 17.

$$V_{OUT2} = V_{OUT1} \times \frac{N_S}{N_P} - V_F \quad (20)$$

where

- $V_F$  is the forward voltage drop of D1
- $N_P$  and  $N_S$  are the number of turns on the primary and secondary of coupled inductor X1.

For output voltage ( $V_{OUT1}$ ) more than one diode drop above the maximum  $V_{CC}$  (8.55 V), the  $V_{CC}$  pin can be diode connected to  $V_{OUT1}$  for higher efficiency and low dissipation in the IC. See AN-2292 *Designing an Isolated Buck (Flyback) Converter* (SNVA674) for a complete isolated bias design using the Fly-Buck topology.

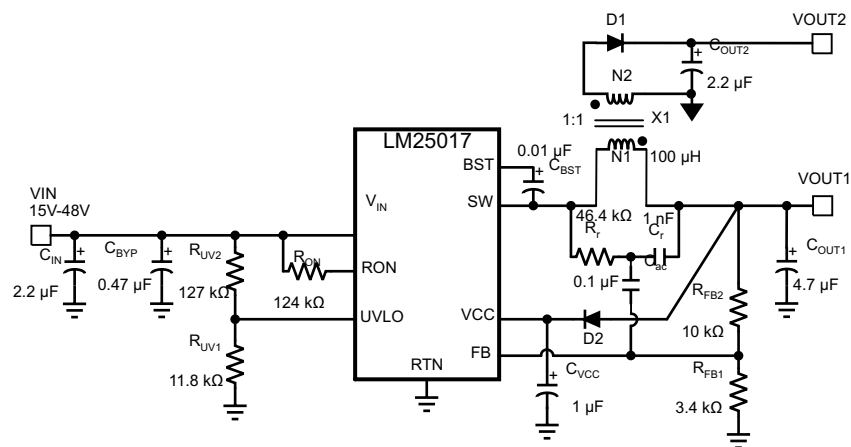

**Figure 8-5. Typical Isolated Application Schematic**

### 8.2.2.1 Design Requirements

Selection of external components is illustrated through a design example. The design example specifications are shown in Table 8-2.

**Table 8-2. Buck Converter Design Specifications**

| DESIGN PARAMETERS                            | VALUE        |
|--|--------------|
| Input Range                                  | 15 V to 48 V |
| Primary Output Voltage                       | 5 V          |
| Secondary (Isolated) Output Voltage          | 4.5 V        |
| Maximum Output Current (Primary + Secondary) | 600 mA       |
| Maximum Power Output                         | 3 W          |
| Nominal Switching Frequency                  | 500 kHz      |

### 8.2.2.2 Detailed Design Procedure

#### 8.2.2.2.1 Transformer Turns Ratio

The transformer turns ratio is selected based on the ratio of the primary output voltage to the secondary (isolated) output voltage. In this design example, the two outputs are nearly equal and a 1:1 turns ratio transformer is selected. Therefore,  $N_2 / N_1 = 1$ . If the secondary (isolated) output voltage is significantly higher or lower than the primary output voltage, a turns ratio less than or greater than 1 is recommended. The primary output voltage is normally selected based on the input voltage range such that the duty cycle of the converter does not exceed 50% at the minimum input voltage. This condition is satisfied if  $V_{OUT1} < V_{IN\_MIN} / 2$ .

#### 8.2.2.2.2 Total I<sub>OUT</sub>

The total primary referred load current is calculated by multiplying the isolated output load(s) by the turns ratio of the transformer as shown in [Equation 18](#).

$$I_{OUT(MAX)} = I_{OUT1} + I_{OUT2} \times \frac{N2}{N1} = 0.6 \text{ A} \quad (21)$$

#### 8.2.2.2.3 RFB1, RFB2

The feedback resistors are selected to set the primary output voltage. The selected value for R<sub>FB1</sub> is 3.4 kΩ. R<sub>FB2</sub> can be calculated using the following equations to set V<sub>OUT1</sub> to the specified value of 5 V. A standard resistor value of 10.0 kΩ is selected for R<sub>FB2</sub>.

$$V_{OUT1} = 1.225V \times \left(1 + \frac{R_{FB2}}{R_{FB1}}\right) \quad (22)$$

$$\rightarrow R_{FB2} = \left(\frac{V_{OUT1}}{1.225} - 1\right) \times R_{FB1} = 10.4 \text{ k}\Omega \quad (23)$$

#### 8.2.2.2.4 Frequency Selection

[Equation 21](#) is used to calculate the value of R<sub>ON</sub> required to achieve the desired switching frequency.

$$f_{SW} = \frac{V_{OUT1}}{K \times R_{ON}} \quad (24)$$

Where K = 9 × 10<sup>-11</sup>F. For V<sub>OUT1</sub> of 5 V and f<sub>SW</sub> of 500 kHz, the calculated value of R<sub>ON</sub> is 111 kΩ. A standard value of 124 kΩ is selected for this design to allow for second order effects at high switching frequency that are not included in [Equation 21](#).

#### 8.2.2.2.5 Transformer Selection

A coupled inductor or a flyback-type transformer is required for this topology. Energy is transferred from primary to secondary when the low-side synchronous switch of the buck converter is conducting.

The maximum inductor primary ripple current that can be tolerated without exceeding the buck switch peak current limit threshold (0.7 A minimum) is given by [Equation 22](#).

$$\Delta I_{L1} = \left(0.7 - I_{OUT1} - I_{OUT2} \times \frac{N2}{N1}\right) \times 2 = 0.2 \text{ A} \quad (25)$$

Using the maximum peak-to-peak inductor ripple current ΔI<sub>L1</sub> from [Equation 22](#), the minimum inductor value is given by [Equation 23](#).

$$L1 = \frac{V_{IN(MAX)} - V_{OUT}}{\Delta I_{L1} \times f_{SW}} \times \frac{V_{OUT}}{V_{IN(MAX)}} = 44.4 \text{ }\mu\text{H} \quad (26)$$

A higher value of 100 μH is selected to insure the high-side switch current does not exceed the minimum peak current limit threshold. With this inductance, the inductor current ripple is ΔI<sub>L1</sub> = 90 mA at the maximum V<sub>IN</sub>.

#### 8.2.2.2.6 Primary Output Capacitor

In a conventional buck converter the output ripple voltage is calculated as shown in [Equation 24](#).

$$\Delta V_{OUT} = \frac{\Delta I_{L1}}{8 \times f \times C_{OUT1}} \quad (27)$$

To limit the primary output ripple voltage ΔV<sub>OUT1</sub> to approximately 25 mV, an output capacitor C<sub>OUT1</sub> of 0.9 μF would be required for a conventional buck.

Figure 8-6 shows the primary winding current waveform ( $I_{L1}$ ) of a Fly-Buck™ converter. The reflected secondary winding current adds to the primary winding current during the buck switch off-time. Because of this increased current, the output voltage ripple is not the same as in conventional buck converter. The output capacitor value calculated in Equation 24 should be used as the starting point. Optimization of output capacitance over the entire line and load range must be done experimentally. If the majority of the load current is drawn from the secondary isolated output, a better approximation of the primary output voltage ripple is given by Equation 25.

$$\Delta V_{OUT1} = \frac{\left( I_{OUT2} \times \frac{N2}{N1} \right) \times T_{ON(MAX)}}{C_{OUT1}} \quad (28)$$

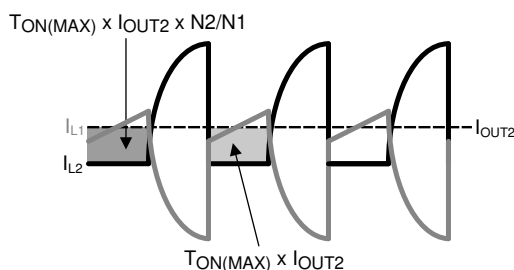
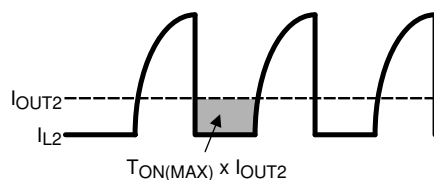

**Figure 8-6. Current Waveforms for  $C_{OUT1}$  Ripple Calculation**

To limit the primary output ripple voltage to approximately 100 mV, an output capacitor of 4  $\mu$ F is required. A standard 4.7- $\mu$ F, 16 V capacitor is selected for this design. If lower output voltage ripple is required, a higher value should be selected for  $C_{OUT1}$  and/or  $C_{OUT2}$ .

#### 8.2.2.2.7 Secondary Output Capacitor

A simplified waveform for secondary output current ( $I_{OUT2}$ ) is shown in Figure 8-7.



**Figure 8-7. Secondary Current Waveforms for  $C_{OUT2}$  Ripple Calculation**

The secondary output current ( $I_{OUT2}$ ) is sourced by  $C_{OUT2}$  during on-time of the buck switch,  $T_{ON}$ . Ignoring the current transition times in the secondary winding, the secondary output capacitor ripple voltage can be calculated using Equation 26.

$$\Delta V_{OUT2} = \frac{I_{OUT2} \times T_{ON(MAX)}}{C_{OUT2}} \quad (29)$$

For a 1:1 transformer turns ratio, the primary and secondary voltage ripple equations are identical. A  $C_{OUT2}$  value of 2.2  $\mu$ F is chosen for this design.

If lower output voltage ripple is required, a higher value should be selected for  $C_{OUT1}$  and/or  $C_{OUT2}$ .

### 8.2.2.2.8 Type III Feedback Ripple Circuit

Type III ripple circuit as described in [Section 7.3.11](#) is required for the Fly-Buck topology. Type I and Type II ripple circuits use series resistance and the triangular inductor ripple current to generate ripple at  $V_{OUT}$  and the FB pin. The primary ripple current of a Fly-Buck is the combination of primary and reflected secondary currents as illustrated in [Figure 8-6](#). In the Fly-Buck topology, Type I and Type II ripple circuits suffer from large jitter as the reflected load current affects the feedback ripple.

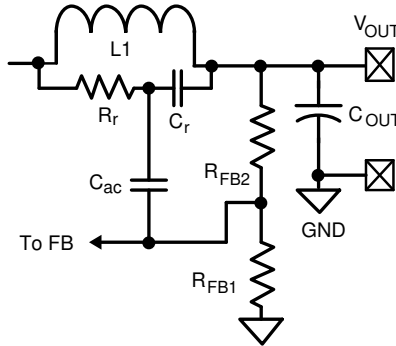

**Figure 8-8. Type III Ripple Circuit**

Selecting the Type III ripple components using the equations from [Table 7-1](#) will ensure that the FB pin ripple is greater than the capacitive ripple from the primary output capacitor  $C_{OUT1}$ . The feedback ripple component values are chosen as shown in [Equation 27](#).

$$R_r C_r \leq \frac{(V_{IN(MIN)} - V_{OUT}) \times T_{ON}}{100 \text{ mV}} \quad (30)$$

The calculated value for  $R_r$  is 66 k $\Omega$ . This value provides the minimum ripple for stable operation. A smaller resistance should be selected to allow for variations in  $T_{ON}$ ,  $C_{OUT1}$  and other components. For this design,  $R_r$  value of 46.4 k $\Omega$  is selected.

### 8.2.2.2.9 Secondary Diode

The reverse voltage across secondary-rectifier diode D1 when the high-side buck switch is off can be calculated using [Equation 28](#).

$$V_{D1} = \frac{N2}{N1} V_{IN} \quad (31)$$

For a  $V_{IN\_MAX}$  of 48 V and the 1:1 turns ratio of this design, a 60 V Schottky is selected.

### 8.2.2.2.10 $V_{CC}$ and Bootstrap Capacitor

A 1- $\mu\text{F}$  capacitor of 16 V or higher rating is recommended for the  $V_{CC}$  regulator bypass capacitor.

A good value for the BST pin bootstrap capacitor is 0.01- $\mu\text{F}$  with a 16 V or higher rating.

### 8.2.2.2.11 Input Capacitor

The input capacitor is typically a combination of a smaller bypass capacitor located near the regulator IC and a larger bulk capacitor. The total input capacitance should be large enough to limit the input voltage ripple to a desired amplitude. For input ripple voltage  $\Delta V_{IN}$ ,  $C_{IN}$  can be calculated using [Equation 29](#).

$$C_{IN} \geq \frac{I_{OUT(MAX)}}{4 \times f \times \Delta V_{IN}} \quad (32)$$

Choosing a  $\Delta V_{IN}$  of 0.5 V gives a minimum  $C_{IN}$  of 0.6  $\mu\text{F}$ . A standard value of 0.47  $\mu\text{F}$  is selected for  $C_{BYP}$  in this design. A bulk capacitor of higher value reduces voltage spikes due to parasitic inductance between the power

source to the converter. A standard value of 2.2  $\mu\text{F}$  is selected for  $C_{\text{IN}}$  in this design. The voltage ratings of the two input capacitors should be greater than the maximum input voltage under all conditions.

#### 8.2.2.2.12 UVLO Resistors

UVLO resistors  $R_{\text{UV1}}$  and  $R_{\text{UV2}}$  set the undervoltage lockout threshold and hysteresis according to [Equation 30](#) and [Equation 31](#).

$$V_{\text{IN (HYS)}} = I_{\text{HYS}} \times R_{\text{UV2}} \quad (33)$$

$$V_{\text{IN (UVLO, rising)}} = 1.225 \text{ V} \times \left( \frac{R_{\text{UV2}}}{R_{\text{UV1}}} + 1 \right) \quad (34)$$

where

- $I_{\text{HYS}} = 20 \mu\text{A}$ , typical.

For a UVLO hysteresis of 2.5 V and UVLO rising threshold of 15 V, [Equation 30](#) and [Equation 31](#) require  $R_{\text{UV1}}$  of 11.8 k $\Omega$  and  $R_{\text{UV2}}$  of 127 k $\Omega$  and these values are selected for this design example.

#### 8.2.2.2.13 V<sub>CC</sub> Diode

Diode D2 is an optional diode connected between  $V_{\text{OUT1}}$  and the  $V_{\text{CC}}$  regulator output pin. When  $V_{\text{OUT1}}$  is more than one diode drop greater than the  $V_{\text{CC}}$  voltage, the  $V_{\text{CC}}$  bias current is supplied from  $V_{\text{OUT1}}$ . This results in reduced power losses in the internal  $V_{\text{CC}}$  regulator which improves converter efficiency.  $V_{\text{OUT1}}$  must be set to a voltage at least one diode drop higher than 8.55 V (the maximum  $V_{\text{CC}}$  voltage) if D2 is used to supply bias current.



### 8.2.2.3 Application Curves

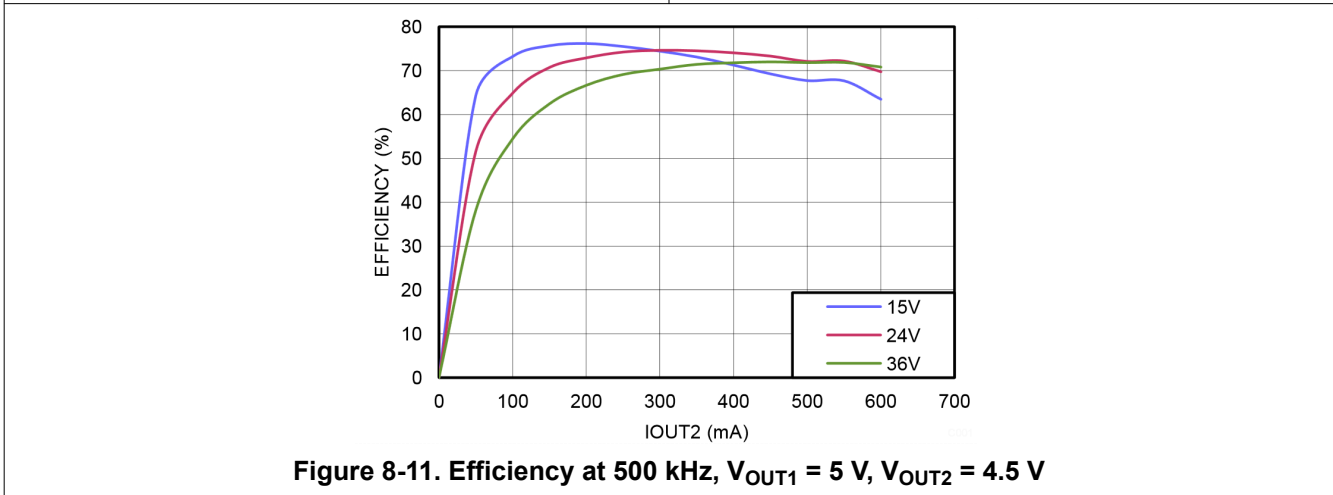
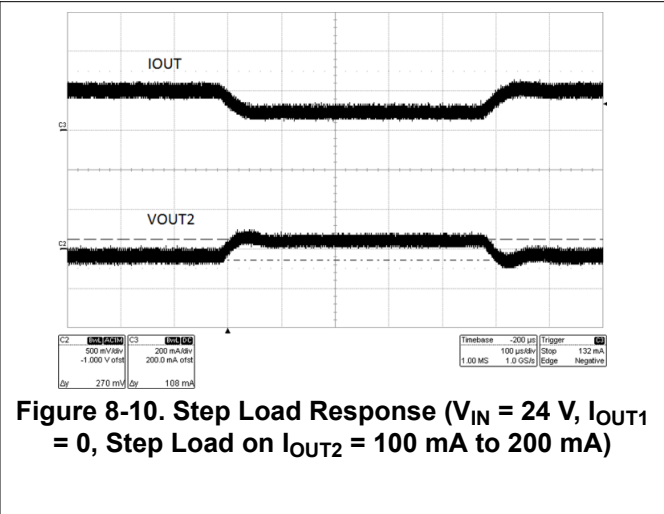
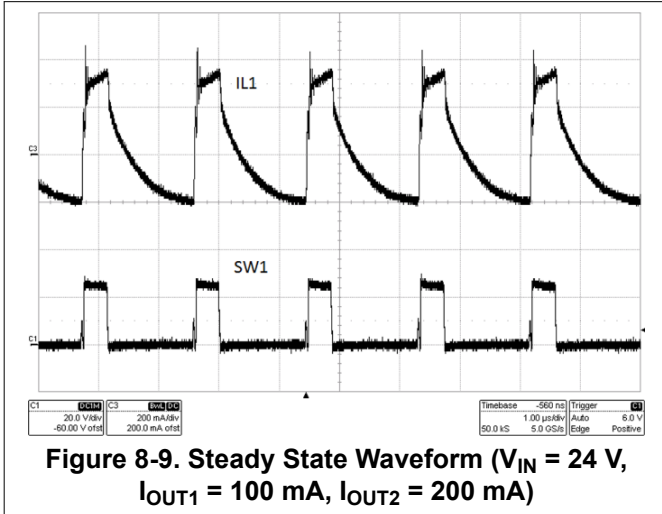

## 9 Power Supply Recommendations

LM25017 is a power management device. The power supply for the device is any dc voltage source within the specified input range.



## 11 Device and Documentation Support

### 11.1 Device Support

#### 11.1.1 Development Support

##### 11.1.1.1 Custom Design With WEBENCH® Tools

[Click here](#) to create a custom design using the LM25017 device with the WEBENCH® Power Designer.

1. Start by entering the input voltage ( $V_{IN}$ ), output voltage ( $V_{OUT}$ ), and output current ( $I_{OUT}$ ) requirements.
2. Optimize the design for key parameters such as efficiency, footprint, and cost using the optimizer dial.
3. Compare the generated design with other possible solutions from Texas Instruments.

The WEBENCH Power Designer provides a customized schematic along with a list of materials with real-time pricing and component availability.

In most cases, these actions are available:

- Run electrical simulations to see important waveforms and circuit performance
- Run thermal simulations to understand board thermal performance
- Export customized schematic and layout into popular CAD formats
- Print PDF reports for the design, and share the design with colleagues

Get more information about WEBENCH tools at [www.ti.com/WEBENCH](http://www.ti.com/WEBENCH).

### 11.2 Documentation Support

#### 11.2.1 Related Documentation

- [AN-1481 Controlling Output Ripple and Achieving ESR Independence in Constant On-Time \(COT\) Regulator Designs](#)
- [AN-2292 Designing an Isolated Buck \(Flyback\) Converter](#)
- [LM25017 Evaluation Board](#)
- [LM25017 Isolated Buck \(FlyBuck\) User's Guide](#)

### 11.3 Receiving Notification of Documentation Updates

To receive notification of documentation updates, navigate to the device product folder on [ti.com](http://ti.com). Click on *Subscribe to updates* to register and receive a weekly digest of any product information that has changed. For change details, review the revision history included in any revised document.

### 11.4 Support Resources

TI E2E™ [support forums](#) are an engineer's go-to source for fast, verified answers and design help — straight from the experts. Search existing answers or ask your own question to get the quick design help you need.

Linked content is provided "AS IS" by the respective contributors. They do not constitute TI specifications and do not necessarily reflect TI's views; see TI's [Terms of Use](#).

### 11.5 Trademarks

Fly-Buck™ and TI E2E™ are trademarks of Texas Instruments.

is a trademark of Texas Instruments.

WEBENCH® are registered trademarks of Texas Instruments.

All trademarks are the property of their respective owners.

### 11.6 Electrostatic Discharge Caution



This integrated circuit can be damaged by ESD. Texas Instruments recommends that all integrated circuits be handled with appropriate precautions. Failure to observe proper handling and installation procedures can cause damage.

ESD damage can range from subtle performance degradation to complete device failure. Precision integrated circuits may be more susceptible to damage because very small parametric changes could cause the device not to meet its published specifications.

## 11.7 Glossary

[TI Glossary](#) This glossary lists and explains terms, acronyms, and definitions.

## 12 Mechanical, Packaging, and Orderable Information

The following pages include mechanical, packaging, and orderable information. This information is the most current data available for the designated devices. This data is subject to change without notice and revision of this document. For browser-based versions of this data sheet, refer to the left-hand navigation.

**PACKAGING INFORMATION**

| Orderable Device | Status<br>(1) | Package Type | Package<br>Drawing | Pins | Package<br>Qty | Eco Plan<br>(2) | Lead finish/<br>Ball material<br>(6) | MSL Peak Temp<br>(3) | Op Temp (°C) | Device Marking<br>(4/5) | Samples                 |
|------------------|---------------|--------------|--------------------|------|----------------|-----------------|--------------------------------------|----------------------|--------------|-------------------------|-------------------------|
| LM25017MR/NOPB   | ACTIVE        | SO PowerPAD  | DDA                | 8    | 95             | RoHS & Green    | SN                                   | Level-3-260C-168 HR  | -40 to 125   | L25017<br>MR            | <a href="#">Samples</a> |
| LM25017MRE/NOPB  | ACTIVE        | SO PowerPAD  | DDA                | 8    | 250            | RoHS & Green    | SN                                   | Level-3-260C-168 HR  | -40 to 125   | L25017<br>MR            | <a href="#">Samples</a> |
| LM25017MRX/NOPB  | ACTIVE        | SO PowerPAD  | DDA                | 8    | 2500           | RoHS & Green    | SN                                   | Level-3-260C-168 HR  | -40 to 125   | L25017<br>MR            | <a href="#">Samples</a> |
| LM25017SD/NOPB   | ACTIVE        | WSON         | NGU                | 8    | 1000           | RoHS & Green    | SN                                   | Level-1-260C-UNLIM   | -40 to 125   | L25017                  | <a href="#">Samples</a> |
| LM25017SDE/NOPB  | ACTIVE        | WSON         | NGU                | 8    | 250            | RoHS & Green    | SN                                   | Level-1-260C-UNLIM   | -40 to 125   | L25017                  | <a href="#">Samples</a> |
| LM25017SDX/NOPB  | ACTIVE        | WSON         | NGU                | 8    | 4500           | RoHS & Green    | SN                                   | Level-1-260C-UNLIM   | -40 to 125   | L25017                  | <a href="#">Samples</a> |

(1) The marketing status values are defined as follows:

**ACTIVE:** Product device recommended for new designs.

**LIFEBUY:** TI has announced that the device will be discontinued, and a lifetime-buy period is in effect.

**NRND:** Not recommended for new designs. Device is in production to support existing customers, but TI does not recommend using this part in a new design.

**PREVIEW:** Device has been announced but is not in production. Samples may or may not be available.

**OBSOLETE:** TI has discontinued the production of the device.

(2) **RoHS:** TI defines "RoHS" to mean semiconductor products that are compliant with the current EU RoHS requirements for all 10 RoHS substances, including the requirement that RoHS substance do not exceed 0.1% by weight in homogeneous materials. Where designed to be soldered at high temperatures, "RoHS" products are suitable for use in specified lead-free processes. TI may reference these types of products as "Pb-Free".

**RoHS Exempt:** TI defines "RoHS Exempt" to mean products that contain lead but are compliant with EU RoHS pursuant to a specific EU RoHS exemption.

**Green:** TI defines "Green" to mean the content of Chlorine (Cl) and Bromine (Br) based flame retardants meet JS709B low halogen requirements of <=1000ppm threshold. Antimony trioxide based flame retardants must also meet the <=1000ppm threshold requirement.

(3) MSL, Peak Temp. - The Moisture Sensitivity Level rating according to the JEDEC industry standard classifications, and peak solder temperature.

(4) There may be additional marking, which relates to the logo, the lot trace code information, or the environmental category on the device.

(5) Multiple Device Markings will be inside parentheses. Only one Device Marking contained in parentheses and separated by a "~" will appear on a device. If a line is indented then it is a continuation of the previous line and the two combined represent the entire Device Marking for that device.

<sup>(6)</sup> Lead finish/Ball material - Orderable Devices may have multiple material finish options. Finish options are separated by a vertical ruled line. Lead finish/Ball material values may wrap to two lines if the finish value exceeds the maximum column width.

**Important Information and Disclaimer:**The information provided on this page represents TI's knowledge and belief as of the date that it is provided. TI bases its knowledge and belief on information provided by third parties, and makes no representation or warranty as to the accuracy of such information. Efforts are underway to better integrate information from third parties. TI has taken and continues to take reasonable steps to provide representative and accurate information but may not have conducted destructive testing or chemical analysis on incoming materials and chemicals. TI and TI suppliers consider certain information to be proprietary, and thus CAS numbers and other limited information may not be available for release.

In no event shall TI's liability arising out of such information exceed the total purchase price of the TI part(s) at issue in this document sold by TI to Customer on an annual basis.

**TAPE AND REEL INFORMATION**

**QUADRANT ASSIGNMENTS FOR PIN 1 ORIENTATION IN TAPE**

\*All dimensions are nominal

| Device          | Package Type | Package Drawing | Pins | SPQ  | Reel Diameter (mm) | Reel Width W1 (mm) | A0 (mm) | B0 (mm) | K0 (mm) | P1 (mm) | W (mm) | Pin1 Quadrant |
|-----------------|--------------|-----------------|------|------|--------------------|--------------------|---------|---------|---------|---------|--------|---------------|
| LM25017MRE/NOPB | SO Power PAD | DDA             | 8    | 250  | 178.0              | 12.4               | 6.5     | 5.4     | 2.0     | 8.0     | 12.0   | Q1            |
| LM25017MRX/NOPB | SO Power PAD | DDA             | 8    | 2500 | 330.0              | 12.4               | 6.5     | 5.4     | 2.0     | 8.0     | 12.0   | Q1            |
| LM25017SD/NOPB  | WSON         | NGU             | 8    | 1000 | 178.0              | 12.4               | 4.3     | 4.3     | 1.3     | 8.0     | 12.0   | Q1            |
| LM25017SDE/NOPB | WSON         | NGU             | 8    | 250  | 178.0              | 12.4               | 4.3     | 4.3     | 1.3     | 8.0     | 12.0   | Q1            |
| LM25017SDX/NOPB | WSON         | NGU             | 8    | 4500 | 330.0              | 12.4               | 4.3     | 4.3     | 1.3     | 8.0     | 12.0   | Q1            |



**TAPE AND REEL BOX DIMENSIONS**

\*All dimensions are nominal

| Device          | Package Type | Package Drawing | Pins | SPQ  | Length (mm) | Width (mm) | Height (mm) |
|-----------------|--------------|-----------------|------|------|-------------|------------|-------------|
| LM25017MRE/NOPB | SO PowerPAD  | DDA             | 8    | 250  | 210.0       | 185.0      | 35.0        |
| LM25017MRX/NOPB | SO PowerPAD  | DDA             | 8    | 2500 | 367.0       | 367.0      | 35.0        |
| LM25017SD/NOPB  | WSON         | NGU             | 8    | 1000 | 210.0       | 185.0      | 35.0        |
| LM25017SDE/NOPB | WSON         | NGU             | 8    | 250  | 210.0       | 185.0      | 35.0        |
| LM25017SDX/NOPB | WSON         | NGU             | 8    | 4500 | 367.0       | 367.0      | 35.0        |

# DDA0008B

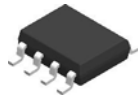

# PACKAGE OUTLINE

## PowerPAD™ SOIC - 1.7 mm max height

PLASTIC SMALL OUTLINE

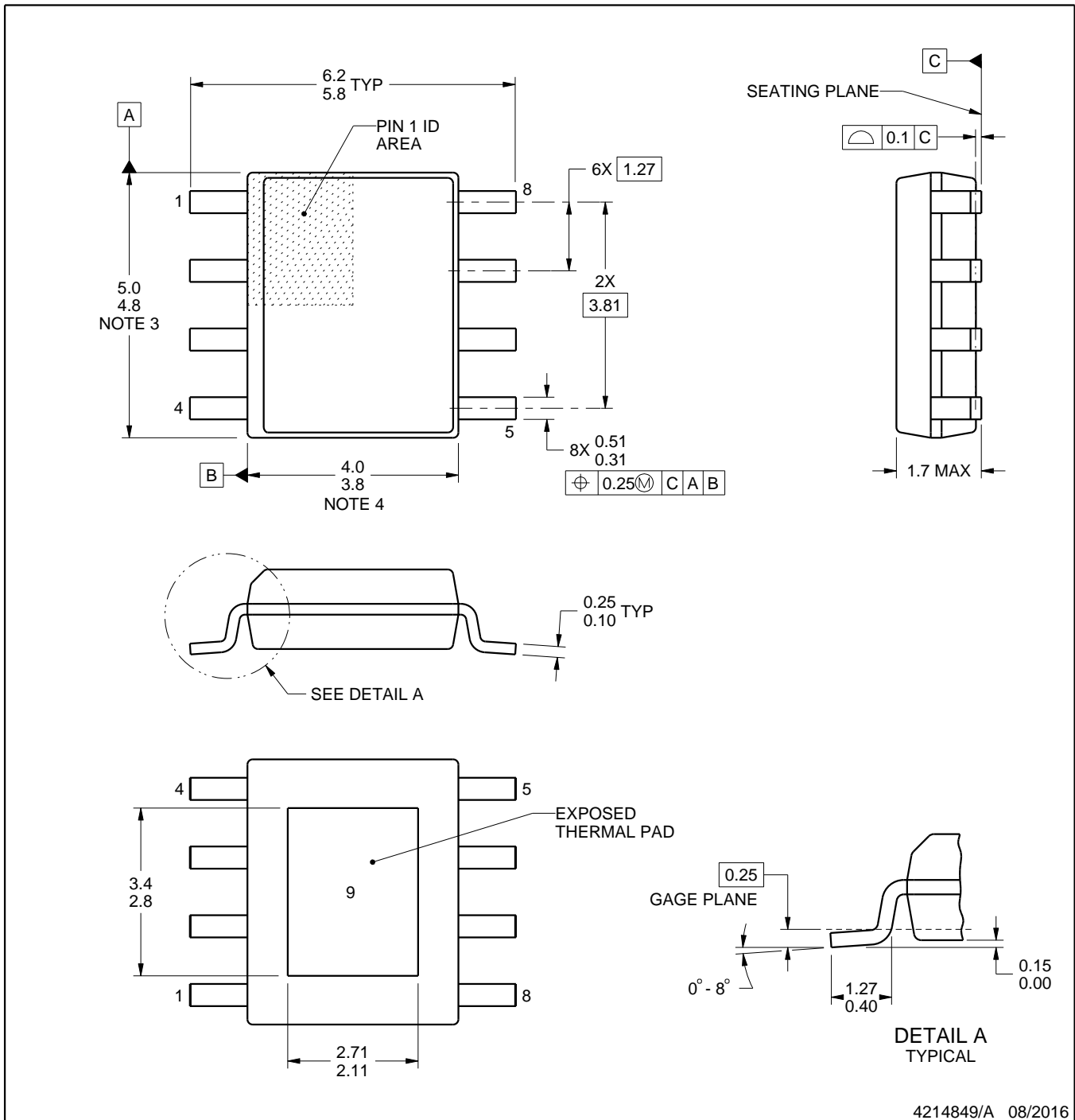

4214849/A 08/2016

### NOTES:

PowerPAD is a trademark of Texas Instruments.

1. All linear dimensions are in millimeters. Any dimensions in parenthesis are for reference only. Dimensioning and tolerancing per ASME Y14.5M.
2. This drawing is subject to change without notice.
3. This dimension does not include mold flash, protrusions, or gate burrs. Mold flash, protrusions, or gate burrs shall not exceed 0.15 mm per side.
4. This dimension does not include interlead flash. Interlead flash shall not exceed 0.25 mm per side.
5. Reference JEDEC registration MS-012.

# EXAMPLE BOARD LAYOUT

DDA0008B

PowerPAD™ SOIC - 1.7 mm max height

PLASTIC SMALL OUTLINE

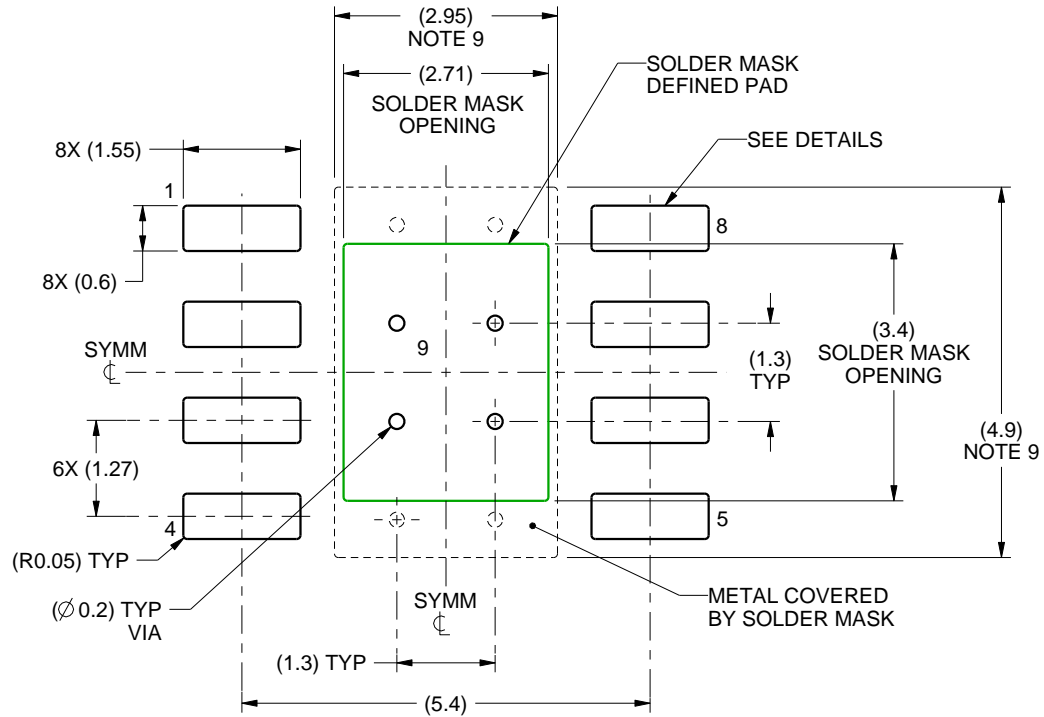

LAND PATTERN EXAMPLE  
SCALE:10X

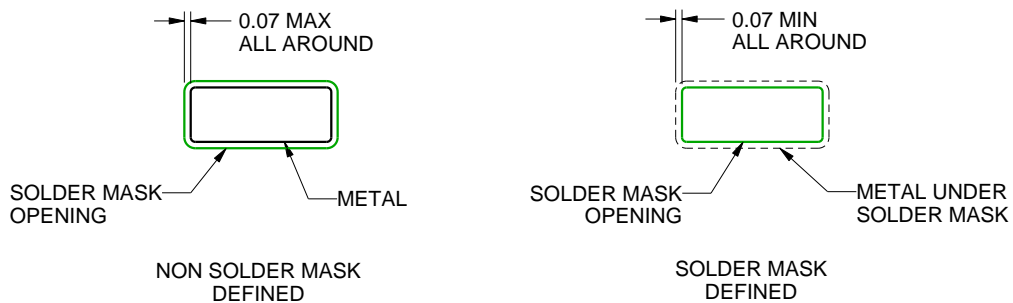

SOLDER MASK DETAILS  
PADS 1-8

4214849/A 08/2016

NOTES: (continued)

6. Publication IPC-7351 may have alternate designs.
7. Solder mask tolerances between and around signal pads can vary based on board fabrication site.
8. This package is designed to be soldered to a thermal pad on the board. For more information, see Texas Instruments literature numbers SLMA002 ([www.ti.com/lit/slma002](http://www.ti.com/lit/slma002)) and SLMA004 ([www.ti.com/lit/slma004](http://www.ti.com/lit/slma004)).
9. Size of metal pad may vary due to creepage requirement.
10. Vias are optional depending on application, refer to device data sheet. If any vias are implemented, refer to their locations shown on this view. It is recommended that vias under paste be filled, plugged or tented.

# EXAMPLE STENCIL DESIGN

DDA0008B

PowerPAD™ SOIC - 1.7 mm max height

PLASTIC SMALL OUTLINE

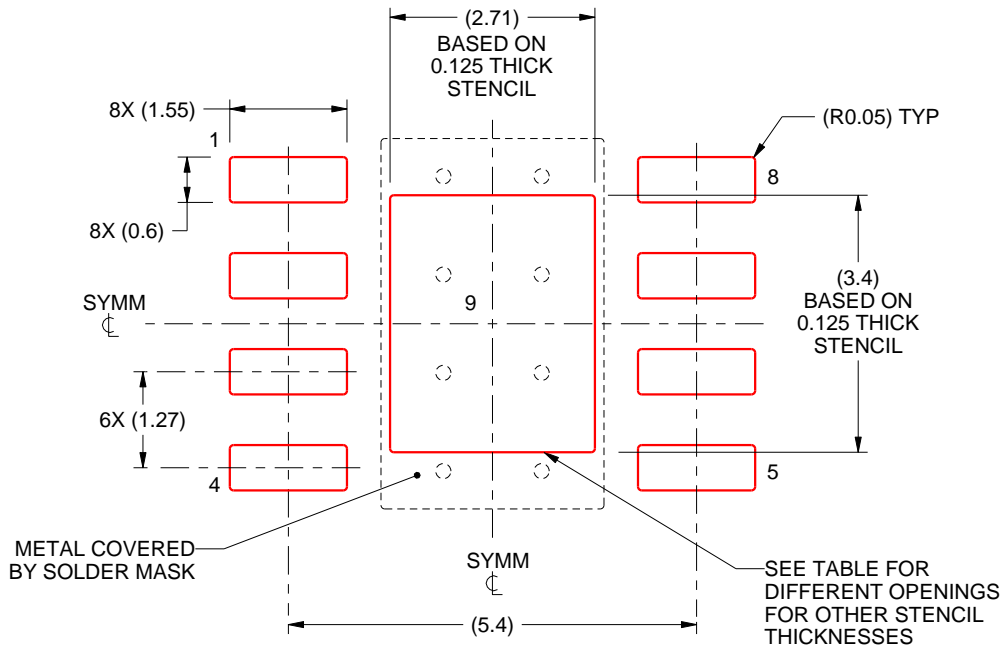

SOLDER PASTE EXAMPLE  
 EXPOSED PAD  
 100% PRINTED SOLDER COVERAGE BY AREA  
 SCALE:10X

| STENCIL THICKNESS | SOLDER STENCIL OPENING |
|-------------------|------------------------|
| 0.1               | 3.03 X 3.80            |
| 0.125             | 2.71 X 3.40 (SHOWN)    |
| 0.150             | 2.47 X 3.10            |
| 0.175             | 2.29 X 2.87            |

4214849/A 08/2016

NOTES: (continued)

11. Laser cutting apertures with trapezoidal walls and rounded corners may offer better paste release. IPC-7525 may have alternate design recommendations.
12. Board assembly site may have different recommendations for stencil design.

NGU0008B

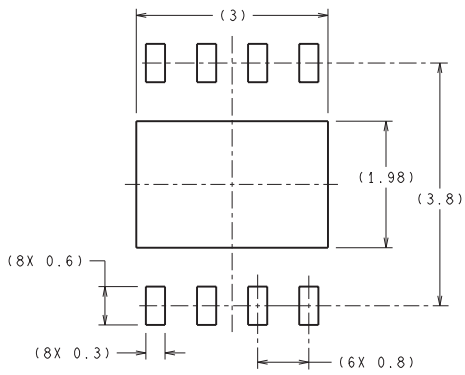

RECOMMENDED LAND PATTERN

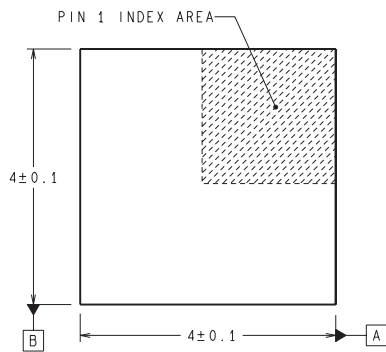

DIMENSIONS ARE IN MILLIMETERS  
DIMENSIONS IN ( ) FOR REFERENCE ONLY

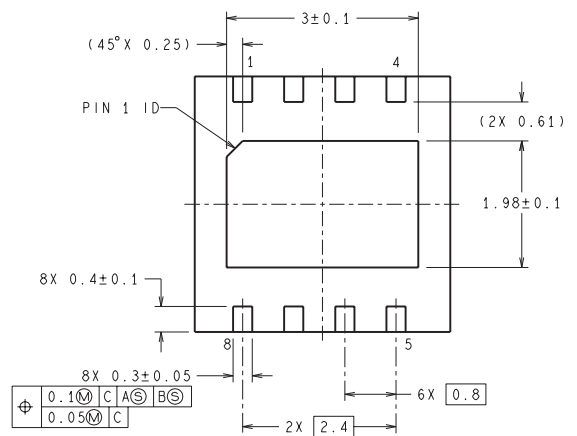
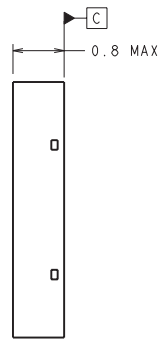
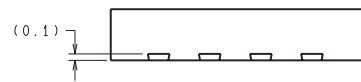

|   |      |   |   |   |   |   |   |
|---|------|---|---|---|---|---|---|
| ⊕ | 0.1  | M | C | A | ⊙ | B | ⊙ |
|   | 0.05 | M | C |   |   |   |   |

SDC08B (Rev A)

## IMPORTANT NOTICE AND DISCLAIMER

TI PROVIDES TECHNICAL AND RELIABILITY DATA (INCLUDING DATASHEETS), DESIGN RESOURCES (INCLUDING REFERENCE DESIGNS), APPLICATION OR OTHER DESIGN ADVICE, WEB TOOLS, SAFETY INFORMATION, AND OTHER RESOURCES "AS IS" AND WITH ALL FAULTS, AND DISCLAIMS ALL WARRANTIES, EXPRESS AND IMPLIED, INCLUDING WITHOUT LIMITATION ANY IMPLIED WARRANTIES OF MERCHANTABILITY, FITNESS FOR A PARTICULAR PURPOSE OR NON-INFRINGEMENT OF THIRD PARTY INTELLECTUAL PROPERTY RIGHTS.

These resources are intended for skilled developers designing with TI products. You are solely responsible for (1) selecting the appropriate TI products for your application, (2) designing, validating and testing your application, and (3) ensuring your application meets applicable standards, and any other safety, security, or other requirements. These resources are subject to change without notice. TI grants you permission to use these resources only for development of an application that uses the TI products described in the resource. Other reproduction and display of these resources is prohibited. No license is granted to any other TI intellectual property right or to any third party intellectual property right. TI disclaims responsibility for, and you will fully indemnify TI and its representatives against, any claims, damages, costs, losses, and liabilities arising out of your use of these resources.

TI's products are provided subject to TI's Terms of Sale (<https://www.ti.com/legal/termsofsale.html>) or other applicable terms available either on [ti.com](https://www.ti.com) or provided in conjunction with such TI products. TI's provision of these resources does not expand or otherwise alter TI's applicable warranties or warranty disclaimers for TI products.

Mailing Address: Texas Instruments, Post Office Box 655303, Dallas, Texas 75265  
Copyright © 2021, Texas Instruments Incorporated