

THIS DOCUMENT IS THE PROPERTY OF KEYSTONE ELECTRONICS CORP. AND SHALL NOT BE REPRODUCED, DISTRIBUTED OR USED AS A BASIS FOR MANUFACTURE WITHOUT PRIOR WRITTEN PERMISSION FROM KEYSTONE ELECTRONICS CORP.

25-07562

ACTUAL SIZE

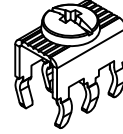

MOUNTING DETAIL

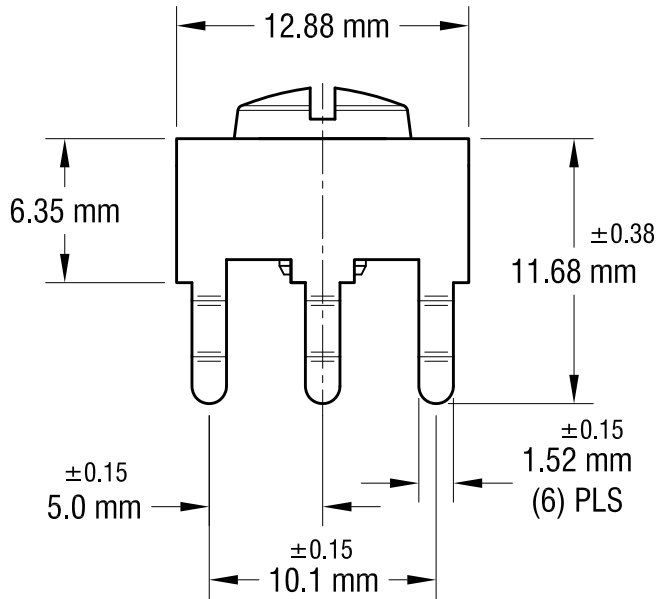
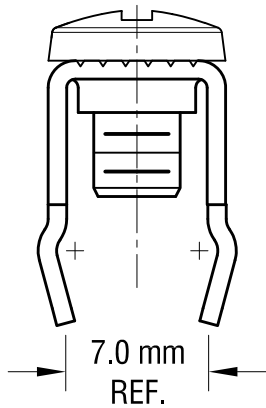
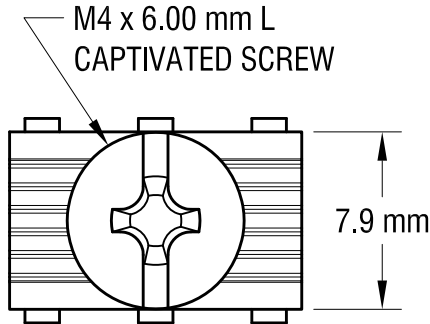
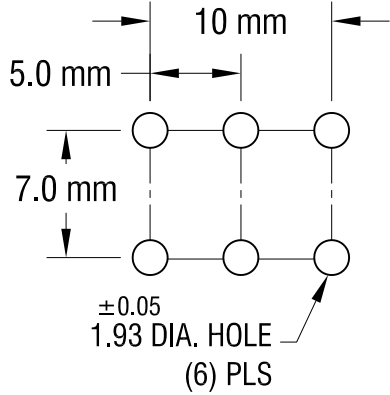

NOTE:

- 1. TERMINAL:
MAT'L - 0.81mm TH'K BRASS, MATTE TIN PLATE
- SCREW : ONE (1) M4 x 6.00mm L.
MAT'L - BRASS, NICKEL PLATE
(SCREW CAPTIVATED)

DATE	DESCRIPTION	REV.
1.28.10	CHANGE AS PER ECN 10-007	C
9.30.09	CHANGE AS PER ECN 09-139	B
11.16.08	CHANGE AS PER ECN 08-182	A

KEYSTONE ELECTRONICS CORP.			
www.keyelco.com • NEW HYDE PARK, NY 11040 • Tel (516) 328-7500			
PART NAME			
METRIC SCREW TERM.& CAPTIVE SCREW			
MATERIAL			
AS NOTED			
FINISH		DRN BY	DATE
AS NOTED		NT	7.02.08
		APP'D	SCALE
		LN	3X
TOLERANCES	INCH [MM]	CODE	DWG NO.
DECIMAL	± [± 0.25]	C	7800
ANGULAR	± 1°		
UNLESS OTHERWISE SPECIFIED			