

SN65HVS883 24 V, Eight-Channel Digital-Input Serializer

1 Features

- Eight Sensor Inputs
 - High Input Voltage up to 34 V
 - Selectable Debounce Filters From 0 ms to 3 ms
 - Adjustable Current Limits From 0.2 mA to 5.2 mA
 - Field Inputs and Supply Lines Protected to 15-kV HBM
- Output Drivers for External Status LEDs
- Cascadable for More Inputs in Multiples of Eight
- SPI-Compatible Interface
- Regulated 5-V Output for External Digital Isolator
- Low-Supply Voltage Indicator

2 Applications

- Sensor Inputs for Industrial Automation and Process Control
 - IEC61131-2 Type 1, 2, or 3 Switches
 - EN60947-5-2 Proximity Switches
- High Channel Count Digital Input Modules for PC and PLC Systems
- Decentralized I/O Modules

3 Description

The SN65HVS883 is a 24-V, eight-channel, digital-input serializer for high-channel density digital input modules of PC and PLC-based systems in industrial automation. In combination with galvanic isolators, the device completes the interface between the 24-V sensor outputs of the field-side and the low-voltage controller inputs at the control-side. Input signals provided by EN60947-5-2 compliant 2-wire and 3-wire proximity switches are current-limited and then validated by internal debounce filters. The input switching characteristic is in accordance with IEC61131-2 for Type 1, 2, and 3 sensor switches.

Upon the application of load and clock signals, input data is latched in parallel into the shift register and afterwards clocked out serially via a subsequent isolator into a serial PLC input.

Cascading of multiple SN65HVS883 is possible by connecting the serial output of the leading device with the serial input of the following device, enabling the design of high-channel count input modules. Input status is indicated via 3-mA constant current LED outputs. An external precision resistor is required to set the internal reference current. The integrated voltage regulator provides a 5-V output to supply low-power isolators. An internal supply voltage monitor provides a chip-okay (CHOK) indication.

The SN65HVS883 comes in a 28-pin PWP PowerPAD™ package allowing for efficient heat dissipation. The device is specified for operation at temperatures from -40°C to 85°C .

Device Information⁽¹⁾

PART NUMBER	PACKAGE	BODY SIZE (NOM)
SN65HVS883	HTSSOP (28)	9.70 mm x 4.40 mm

(1) For all available packages, see the orderable addendum at the end of the data sheet.

Simplified I/O Structure

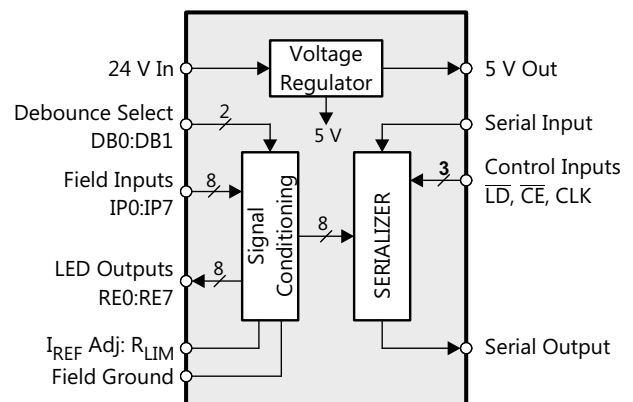

Copyright © 2016, Texas Instruments Incorporated



Table of Contents

1 Features	1	8.1 Overview	10
2 Applications	1	8.2 Functional Block Diagram	10
3 Description	1	8.3 Feature Description	11
4 Revision History	2	8.4 Device Functional Modes	14
5 Pin Configuration and Functions	3	9 Application and Implementation	15
6 Specifications	4	9.1 Application Information	15
6.1 Absolute Maximum Ratings	4	9.2 Typical Application	18
6.2 ESD Ratings	4	10 Power Supply Recommendations	21
6.3 Recommended Operating Conditions	4	11 Layout	21
6.4 Thermal Information	4	11.1 Layout Guidelines	21
6.5 Electrical Characteristics	5	11.2 Layout Example	21
6.6 Timing Requirements	6	12 Device and Documentation Support	22
6.7 Switching Characteristics	6	12.1 Third-Party Products Disclaimer	22
6.8 Typical Input Characteristics	7	12.2 Receiving Notification of Documentation Updates	22
6.9 Typical Voltage Regulator Performance Characteristics	8	12.3 Community Resources	22
7 Parameter Measurement Information	9	12.4 Trademarks	22
7.1 Waveforms	9	12.5 Electrostatic Discharge Caution	22
7.2 Signal Conventions	9	12.6 Glossary	22
8 Detailed Description	10	13 Mechanical, Packaging, and Orderable Information	22

4 Revision History

NOTE: Page numbers for previous revisions may differ from page numbers in the current version.

DATE	REVISION	NOTES
September 2016	*	Initial release.

5 Pin Configuration and Functions

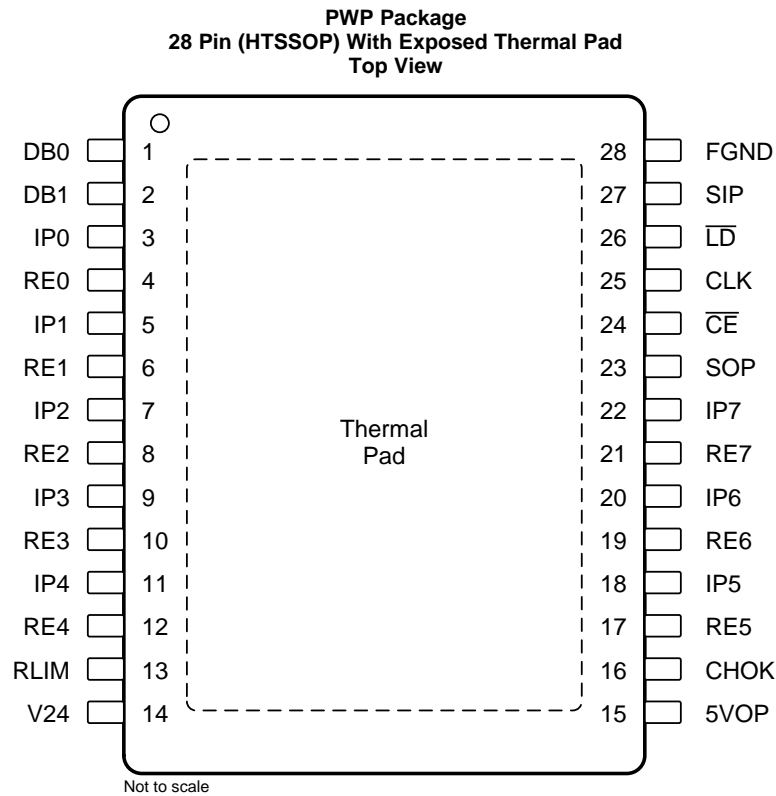

Pin Functions

PIN		DESCRIPTION
PIN NO.	NAME	
1, 2	DB0, DB1	Debounce select inputs
3, 5, 7, 9, 11, 18, 20, 22	IPx	Input channel x
4, 6, 8, 10, 12, 17, 19, 21	REx	Return path x (LED drive)
13	RLIM	Current limiting resistor
14	V24	24 VDC field supply
15	5VOP	5 V output to supply low-power isolators
16	CHOK	Chip okay indicator output
23	SOP	Serial data output
24	\overline{CE}	Clock enable input
25	CLK	Serial clock input
26	\overline{LD}	Load pulse input
27	SIP	Serial data input
28	FGND	Field ground

6 Specifications

6.1 Absolute Maximum Ratings

over operating free-air temperature range (unless otherwise noted)

			MIN	MAX	UNIT
V ₂₄	Field power input	V ₂₄	-0.3	36	V
V _{IPx}	Field digital inputs	IPx	-0.3	36	V
V _{ID}	Voltage at any logic input	DB0, DB1, CLK, SIP, \overline{CE} , \overline{LD}	-0.5	6	V
I _O	Output current	CHOK, SOP		±8	mA
P _{TOT}	Continuous total power dissipation		See Thermal Information table		
T _J	Junction temperature			170	°C

6.2 ESD Ratings

			VALUE	UNIT	
V _(ESD)	Electrostatic discharge	Human-body model (HBM), per ANSI/ESDA/JEDEC JS-001 ⁽¹⁾	All pins	±4000	V
			IPx, V ₂₄	±15000	
		Charged-device model (CDM), per JEDEC specification JESD22-C101 ⁽²⁾	All pins	±1000	
			Machine Mode ⁽³⁾	All pins	

(1) JEDEC document JEP155 states that 500-V HBM allows safe manufacturing with a standard ESD control process.

(2) JEDEC document JEP157 states that 250-V CDM allows safe manufacturing with a standard ESD control process.

(3) JEDEC Standard 22, Method A115-A.

6.3 Recommended Operating Conditions

			MIN	TYP	MAX	UNIT
V ₂₄	Field supply voltage		10	24	34	V
V _{IPL}	Field input low-state input voltage ⁽¹⁾		0		4	V
V _{IPH}	Field input high-state input voltage ⁽¹⁾		10		34	V
V _{IL}	Logic low-state input voltage		0		0.8	V
V _{IH}	Logic high-state input voltage		2		5.5	V
R _{LIM}	Current limiter resistor		17	25	500	kΩ
f _{IP}	Input data rate ⁽²⁾		0		1	Mbps
T _J					150	°C
T _A			-40		85	°C

 (1) Field input voltages correspond to an input resistor of R_{IN} = 1.2 kΩ

 (2) Maximum data rate corresponds to 0 ms debounce time, (DB0 = open, DB1 = FGND), and R_{IN} = 0 Ω

6.4 Thermal Information

THERMAL METRIC ⁽¹⁾			SN65HVS883	UNIT
			PWP (HTSSOP)	
			28 PINS	
R _{θJA}	Junction-to-ambient thermal resistance		35	°C/W
R _{θJC(top)}	Junction-to-case (top) thermal resistance		4.27	°C/W
R _{θJB}	Junction-to-board thermal resistance		15	°C/W
PD	Device power dissipation	I _{LOAD} = 50 mA, R _{IN} = 0, IPO–IP7 = V ₂₄ = 30 V, RE7 = FGND, f _{CLK} = 100 MHz, I _{IP-LIM} and I _{CC} = worst case with R _{LIM} = 25 kΩ	2591	mW

 (1) For more information about traditional and new thermal metrics, see the [Semiconductor and IC Package Thermal Metrics](#) application report.

6.5 Electrical Characteristics

 all voltages measured against FGND unless otherwise stated, see [Figure 12](#)

SYMBOL	PARAMETER	PIN	TEST CONDITIONS	MIN	TYP	MAX	UNIT	
$V_{TH-(IP)}$	Low-level device input threshold voltage	IP0–IP7	18 V < V ₂₄ < 34 V, R _{IN} = 0 Ω, R _{LIM} = 25 kΩ	4	4.3		V	
$V_{TH+(IP)}$	High-level device input threshold voltage				5.2	5.5	V	
$V_{HYS(IP)}$	Device input hysteresis				0.9		V	
$V_{TH-(IN)}$	Low-level field input threshold voltage	measured at field side of R _{IN}	18 V < V ₂₄ < 34 V, R _{IN} = 1.2 kΩ ± 5%, R _{LIM} = 25 kΩ	6	8.4		V	
$V_{TH+(IN)}$	High-level field input threshold voltage				9.4	10	V	
$V_{HYS(IN)}$	Field input hysteresis				1		V	
$V_{TH-(V24)}$	Low-level V24-monitor threshold voltage	V24		15	16.05		V	
$V_{TH+(V24)}$	High-level V24-monitor threshold voltage					16.8	18	V
$V_{HYS(V24)}$	V24-monitor hysteresis					0.75		V
R _{IP}	Input resistance	IP0–IP7	3 V < V _{IPX} < 6 V, R _{IN} = 1.2 kΩ ± 5%, R _{LIM} = 25 kΩ	1.4	1.83	2.3	kΩ	
I _{IP-LIM}	Input current limit				10 V < V _{IPX} < 34 V, R _{LIM} = 25 kΩ	3.15	3.6	4
V _{OL}	Logic low-level output voltage	SOP, CHOK	I _{OL} = 20 μA			0.4	V	
V _{OH}	Logic high-level output voltage			I _{OH} = –20 μA	4			V
I _{IL}	Logic input leakage current	DB0, DB1, SIP, LD, CE, CLK		–50		50	μA	
I _{RE-on}	RE on-state current	RE0–RE7	R _{LIM} = 25 kΩ, RE _X = FGND	2.8	3.15	3.5	mA	
I _{CC(V24)}	Supply current	V24	IP0 to IP7 = V24, 5VOP = open, RE _X = FGND, All logic inputs open			8.7	mA	
V _{O(5V)}	Linear regulator output voltage	5VOP	18 V < V ₂₄ < 34 V, no load	4.5	5	5.5	V	
			18 V < V ₂₄ < 34 V, I _L = 50 mA	4.5	5	5.5		
I _{LIM(5V)}	Linear regulator output current limit				115		mA	
$\Delta V_5/\Delta V_{24}$	Line regulation	5VOP, V24	18 V < V ₂₄ < 34 V, I _L = 5 mA			2	mV/V	
t _{DB}	Debounce times of input channels	IP0–IP7	DB0 = open, DB1 = FGND		0		ms	
			DB0 = FGND, DB1 = open		1			
			DB0 = DB1 = open		3			
t _{DB-HL}	Voltage monitor debounce time after V24 < 15 V (CHOK turns low)	V24, CHOK			1		ms	
t _{DB-LH}	Voltage monitor debounce time after V24 > 18 V (CHOK turns high)				6		ms	
T _{SHDN}	Shutdown temperature				170		°C	

6.6 Timing Requirements

over operating free-air temperature range (unless otherwise noted)

SYMBOL	PARAMETER	MIN	TYP	MAX	UNIT
t_{W1}	CLK pulse width See Figure 9	4			ns
t_{W2}	\overline{LD} pulse width See Figure 7	6			ns
t_{SU1}	SIP to CLK setup time See Figure 10	4			ns
t_{H1}	SIP to CLK hold time See Figure 10	2			ns
t_{SU2}	Falling edge to rising edge (\overline{CE} to CLK) setup time See Figure 11	4			ns
t_{REC}	\overline{LD} to CLK recovery time See Figure 8	2			ns
f_{CLK}	Clock pulse frequency (50% duty cycle) See Figure 9	DC		100	MHz

6.7 Switching Characteristics

over operating free-air temperature range (unless otherwise noted)

SYMBOL	PARAMETER	TEST CONDITIONS	MIN	TYP	MAX	UNIT
t_{PLH1}, t_{PHL1}	CLK to SOP	$C_L = 15$ pF, see Figure 9			10	ns
t_{PLH2}, t_{PHL2}	\overline{LD} to SOP	$C_L = 15$ pF, see Figure 7			14	ns
t_r, t_f	Rise and fall times	$C_L = 15$ pF, see Figure 9			5	ns

6.8 Typical Input Characteristics

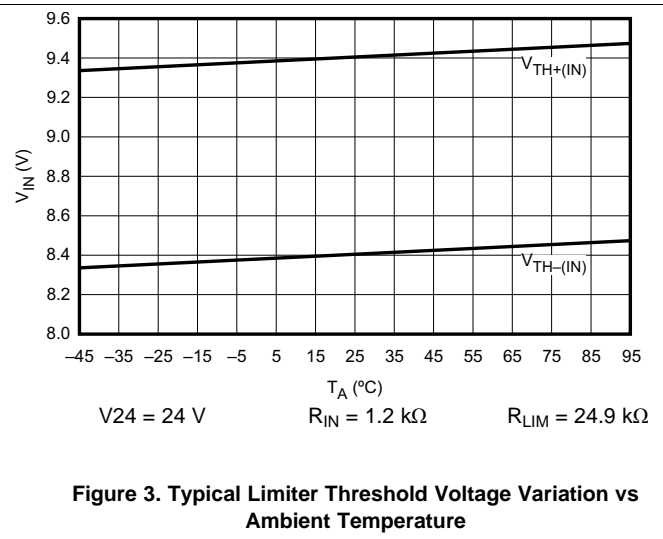
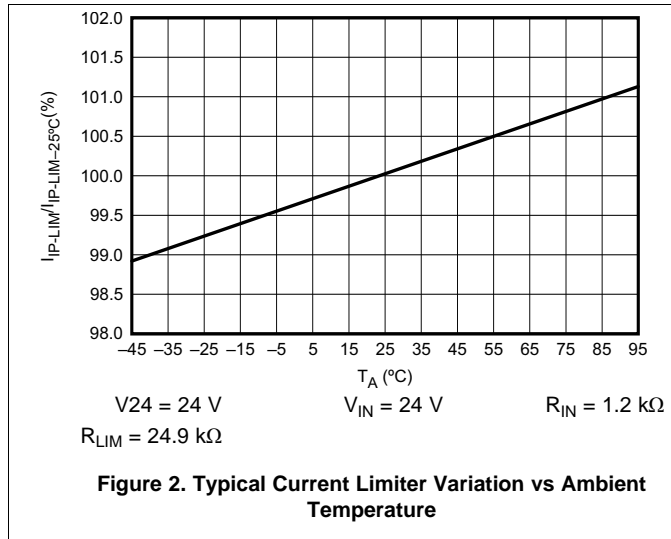
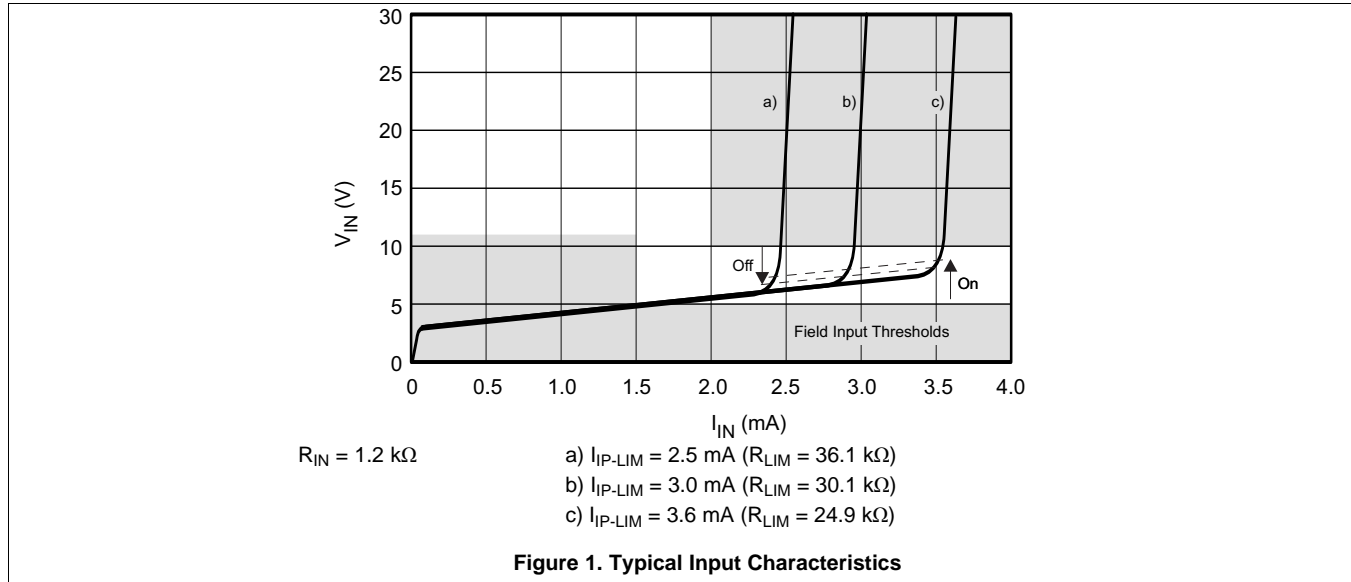

6.9 Typical Voltage Regulator Performance Characteristics

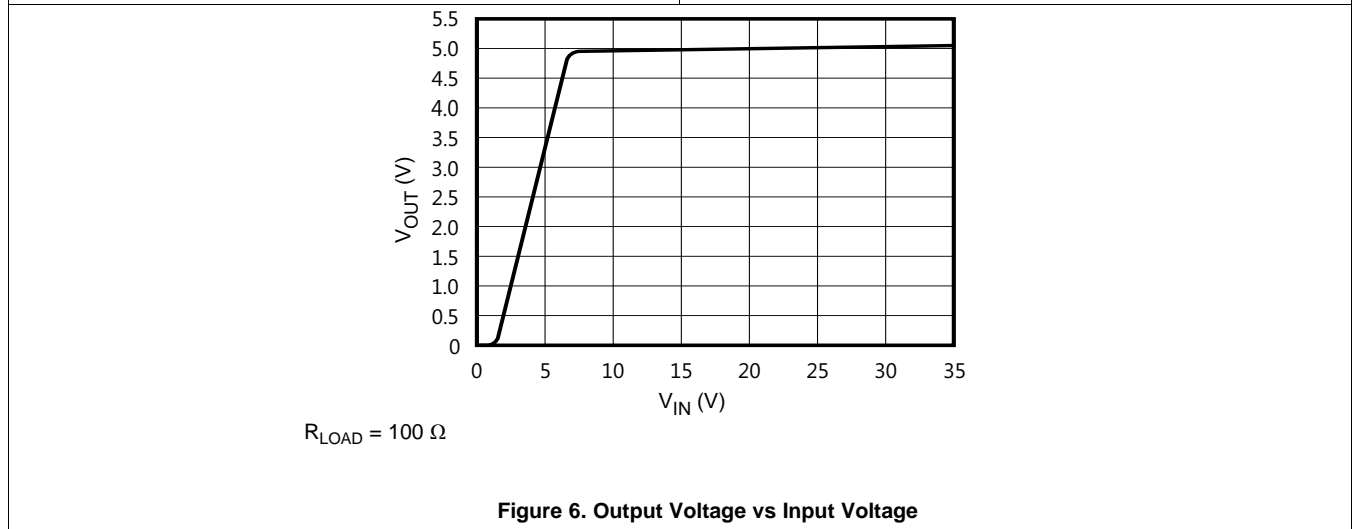
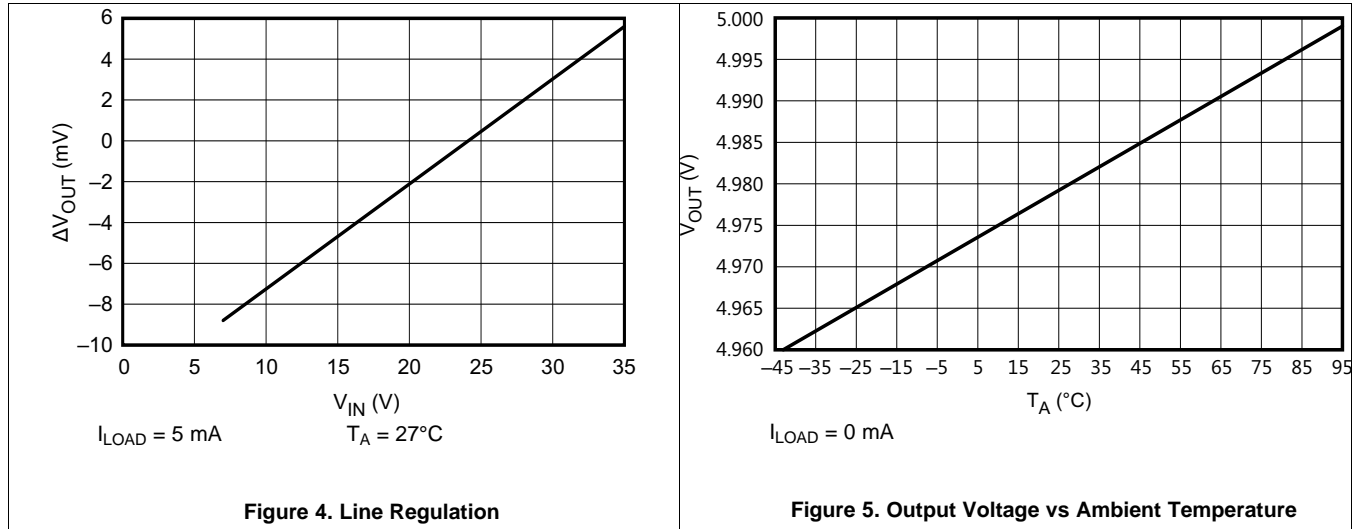

7 Parameter Measurement Information

7.1 Waveforms

For the complete serial interface timing, refer to [Figure 21](#).

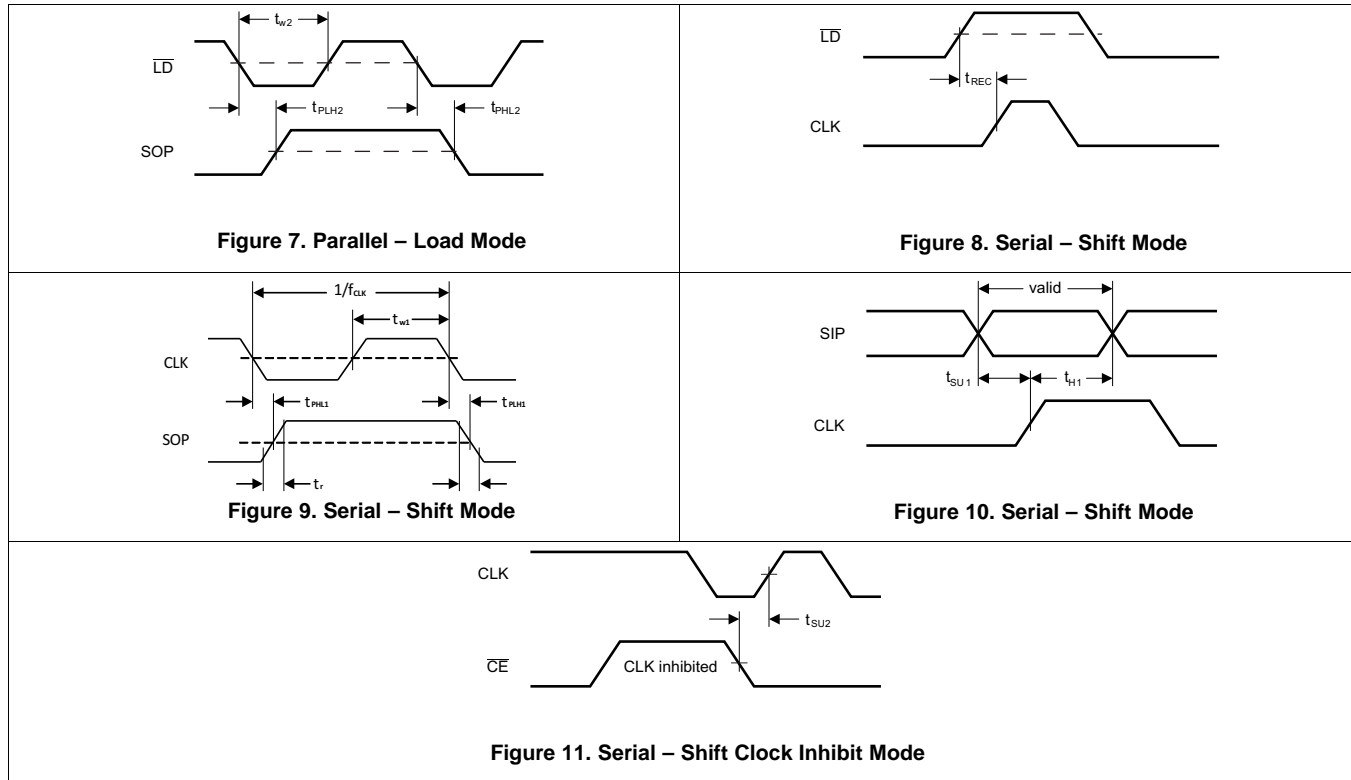

7.2 Signal Conventions

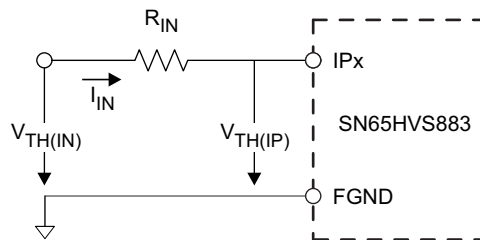

Copyright © 2016, Texas Instruments Incorporated

Figure 12. On/Off Threshold Voltage Measurements

8 Detailed Description

8.1 Overview

The SN65HVS883 is an 8 channel, digital input serializer which operates from a 24 V supply and accepts digital inputs of up to 34 V on the 8 channels (IP0-IP7). The device provides a serially shifted digital output with reduced voltage ranges of 0-5 V for applications in industrial and building automation systems. The SN65HVS883 meets JEDEC standards for ESD protection (refer to [ESD Ratings](#)), and is SPI compatible for interfacing with standard microcontrollers. The serializer operates in 2 fundamental modes: Load Mode and Shift mode. In Load mode, information from the field inputs is allowed to latch into the shift register. In Shift mode, the information stored in the parallel shift register can be serially shifted to the serial output (SOP). A detailed description of the functional modes is available in the [Device Functional Modes](#) section.

8.2 Functional Block Diagram

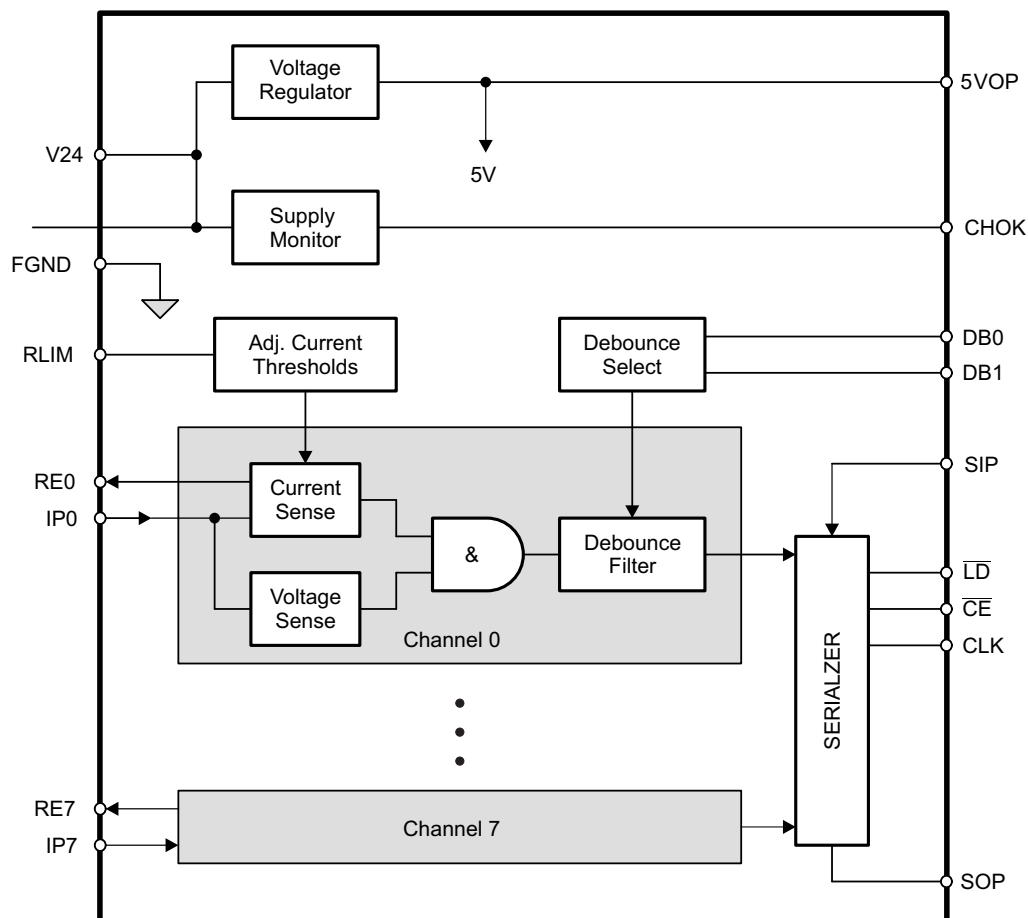

Copyright © 2016, Texas Instruments Incorporated

8.3 Feature Description

8.3.1 Digital Inputs

Each digital input operates as a controlled current sink limiting the input current to a maximum value of I_{LIM} . The current limit is derived from the reference current via $I_{LIM} = n \times I_{REF}$, and I_{REF} is determined by $I_{REF} = V_{REF}/R_{LIM}$. Thus, changing the current limit requires the change of R_{LIM} to a different value via: $R_{LIM} = n \times V_{REF}/I_{LIM}$.

Inserting the actual values for n and V_{REF} gives: $R_{LIM} = 90 \text{ V} / I_{LIM}$.

While the device is specified for a current limit of **3.6 mA**, (via $R_{LIM} = 25 \text{ k}\Omega$), it is easy to lower the current limit to further reduce the power consumption. For example, for a current limit of **2.5 mA** simply calculate:

$$R_{LIM} = \frac{90 \text{ V}}{I_{LIM}} = \frac{90 \text{ V}}{2.5 \text{ mA}} = 36 \text{ k}\Omega \tag{1}$$

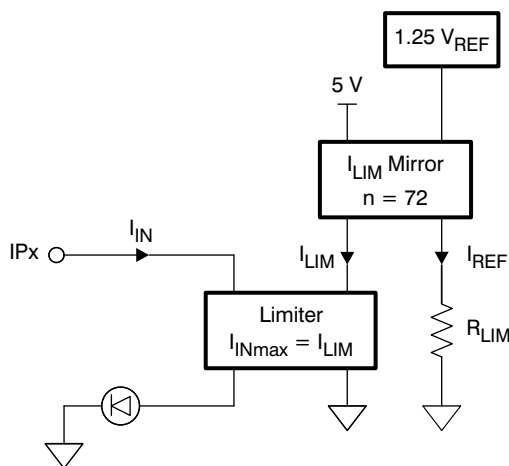

Figure 13. Digital Input Stage

8.3.2 Debounce Filter

The HVS883 applies a simple analog/digital filtering technique to remove unintended signal transitions due to contact bounce or other mechanical effects. Any new input (either low or high) must be present for the duration of the selected debounce time to be latched into the shift register as a valid state.

The logic signal levels at the control inputs, DB0 and DB1 of the internal Debounce-Select logic determine the different debounce times listed in the following truth table.

Table 1. Debounce Times

DB1	DB0	FUNCTION
Open	Open	3 ms delay
Open	FGND	1 ms delay
FGND	Open	0 ms delay (Filter bypassed)
FGND	FGND	Reserved

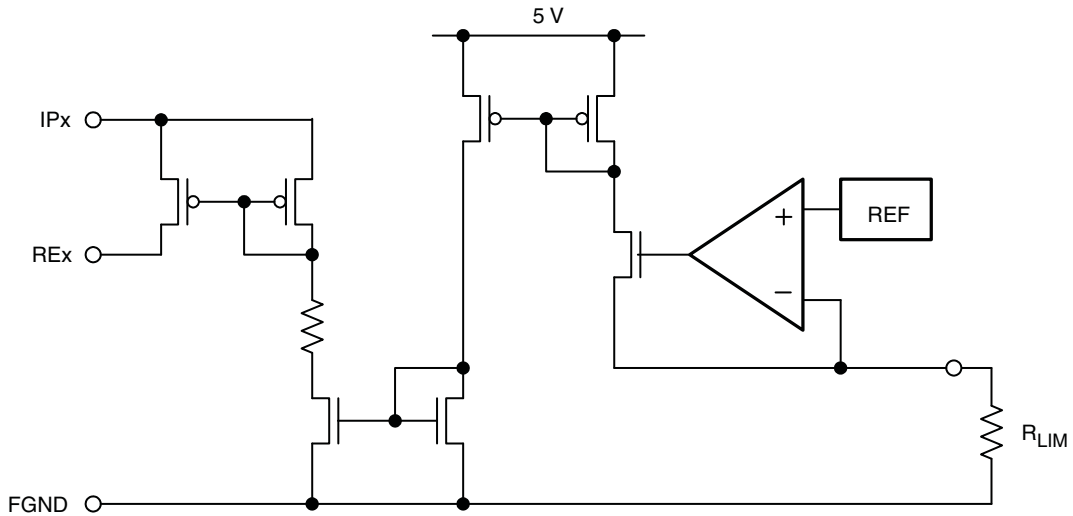

Figure 14. Equivalent Input Diagram

8.3.3 Shift Register

The conversion from parallel input to serial output data is performed by an eight-channel, parallel-in serial-out shift register. Parallel-in access is provided by the internal inputs, PIP0–PIP7, that are enabled by a low level at the load input (LD). When clocked, the latched input data shift towards the serial output (SOP). The shift register also provides a clock-enable function.

Clocking is accomplished by a low-to-high transition of the clock (CLK) input while \overline{LD} is held high and the clock enable (\overline{CE}) input is held low for all registers in the shift register except the last register which is latched by a high-to-low transition. Parallel loading is inhibited when LD is held high. The parallel inputs to the register are enabled while \overline{LD} is low independently of the levels of the CLK, \overline{CE} , or serial (SIP) inputs.

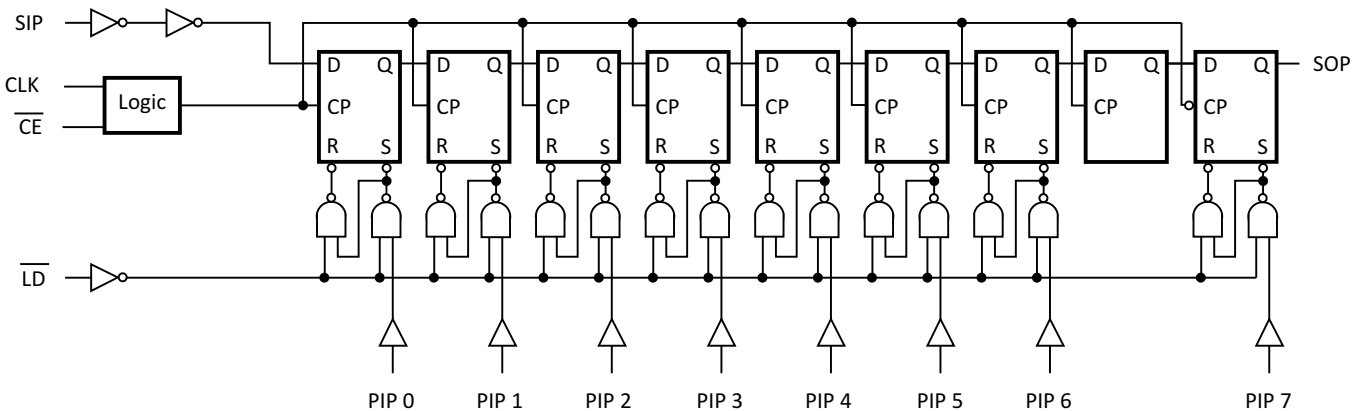

Figure 15. Shift Register Logic Structure

Table 2. Function Table

INPUTS			FUNCTION
$\overline{\text{LD}}$	CLK	$\overline{\text{CE}}$	
L	X	X	Parallel load
H	X	H	No change
H	↑	L	Shift ⁽¹⁾
H	↓	L	Shift ⁽²⁾

- (1) Shift = content of each internal register, except the last register, shifts towards serial output.
- (2) Shift = content of the last register shifts towards serial output.

8.3.4 Voltage Regulator

The on-chip linear voltage regulator provides a 5 V supply to the internal- and external circuitry, such as digital isolators, with an output drive capability of 50 mA and a typical current limit of 115 mA. The regulator accepts input voltages from 34 V down to 10 V. Because the regulator output is intended to supply external digital isolator circuits proper output voltage decoupling is required. For best results connect a 1 μF and a 0.1 μF ceramic capacitor as close as possible to the 5VOP-output. For longer traces between the SN65HVS883 and isolators of the ISO72xx family use additional 0.1 μF and 10 pF capacitors next to the isolator supply pins. Make sure, however, that the total load capacitance does not exceed 4.7 μF.

For good stability the voltage regulator requires a minimum load current, I_{L-MIN} . Ensure that under any operating condition the ratio of the minimum load current in mA to the total load capacitance in μF is larger than 1:

$$\frac{I_{L-MIN}}{C_L} > \frac{1 \text{ mA}}{1 \mu\text{F}} \tag{2}$$

8.3.5 Supply Voltage Monitor

The integrated supply voltage monitor senses the supply voltage of the SN65HVS883 at the V24-pin. If this voltage drops below 15 V but stays within the regulator’s operating range, i.e., $15 \text{ V} > V_{24} > 10 \text{ V}$, the output CHOK goes low 1 ms later. When the supply voltage returns to 24 V, the CHOK output turns logic high after 6 ms. Should the supply voltage drop below 10 V, the device ceases operation. Upon the supply returning to above 18 V, the CHOK output turns high again after 6 ms.

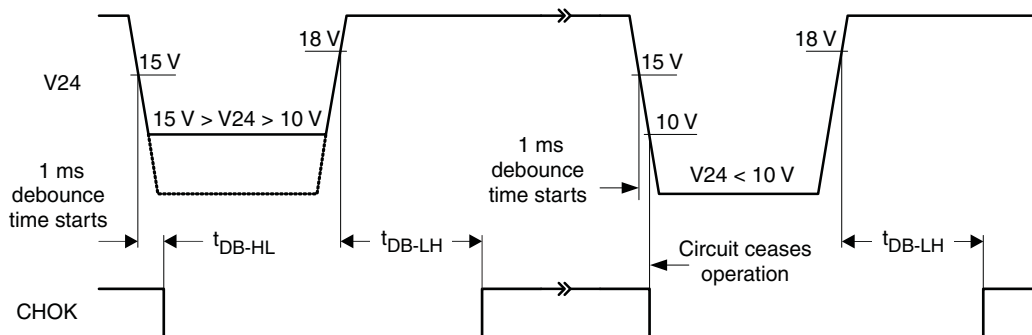

Figure 16. CHOK Output Timing as a Function of Supply Voltage Drop at V24

8.4 Device Functional Modes

The 2 functional modes of operation are Load mode and Shift mode.

Load mode enables information from the field inputs to latch into the shift register. To enter load mode, the $\overline{\text{LD}}$ pin must be held low, and the device remains in load mode regardless of the CLK, $\overline{\text{CE}}$, or serial (SIP) input levels. A high level at the $\overline{\text{LD}}$ pin switches the device into Shift mode.

When the device is in Shift mode, a low level at the $\overline{\text{CE}}$ pin causes the data stored in all registers of the parallel shift register except for the last register, to be serially shifted toward the serial output (SOP) on the rising edge of CLK. The final register in the shift register will be shifted toward the serial output (SOP) on the falling edge of CLK. A high level at the $\overline{\text{CE}}$ pin inhibits the serial shifting, which is demonstrated in [Figure 21](#). After 8 consecutive CLK cycles, the serial output (SOP) remains at the level of the serial input (SIP) which is internally pulled to logic high. A logic high at the $\overline{\text{CE}}$ pin is required to signify the end of the serial data output. For of a daisy chained configuration, the serial output (SOP) of the SN65HVS883 can be connected to the serial input (SIP) of a following device, and additional clock cycles are required to shift the additional data out of the chain. The number of consecutive clock cycles will equal 8 times the number of devices in the chain. See [Figure 22](#) for an example of a cascaded chain of 4x SN65HVS883.

9 Application and Implementation

NOTE

Information in the following applications sections is not part of the TI component specification, and TI does not warrant its accuracy or completeness. TI's customers are responsible for determining suitability of components for their purposes. Customers should validate and test their design implementation to confirm system functionality.

9.1 Application Information

9.1.1 System-Level EMC

The SN65HVS883 must operate reliably in harsh industrial environments. At a system level, the device is tested according to several international electromagnetic compatibility (EMC) standards.

In addition to the device internal ESD structures, external protection circuitry, such as the one in [Figure 17](#), can be used to absorb as much energy from burst- and surge-transients as possible.

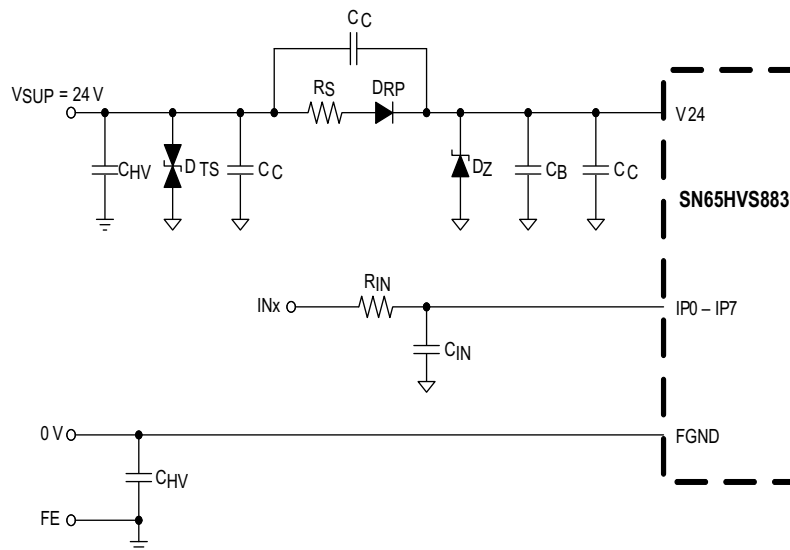

Copyright © 2016, Texas Instruments Incorporated

Figure 17. Typical EMC Protection Circuitry for Supply and Signal Inputs

Table 3. Components

DESIGNATOR	DESCRIPTION
D _{TS}	39 V Transient Voltage Suppressor: SM15T39CA
D _{RP}	Super Rectifier: BYM10-1000, or General Purpose rectifier: 1N4007
D _Z	33 V – 36 V fast Zener Diode, Z2SMB36
R _S	56 Ω, 1/3 W MELF Resistor
R _{IN}	1.2 kΩ, 1/4 W MELF Resistor
C _{IN}	22 nF, 60 V Ceramic Capacitor
C _{HV}	4.7 nF, 2 kV Ceramic Capacitor
C _C	n x 220 nF, 60 V Ceramic Capacitors
C _B	1 μF - 10 μF, 60 V Ceramic Capacitor

9.1.2 Input Channel Switching Characteristics

The input stage of the SN65HVS883 is so designed, that for an input resistor $R_{IN} = 1.2\text{ k}\Omega$ the trip point for signalling an ON-condition is at 9.4 V at 3.6 mA. This trip point satisfies the switching requirements of IEC61131-2 Type 1 and Type 3 switches.

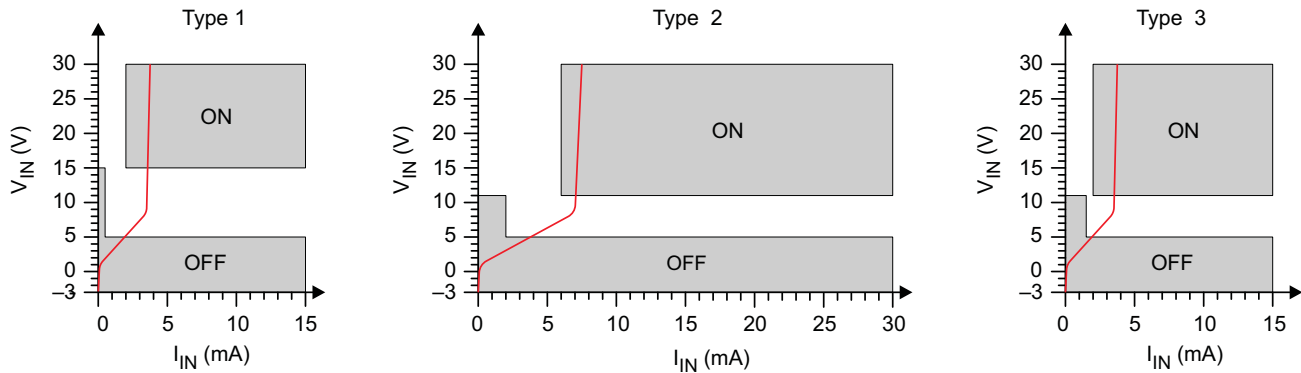

Figure 18. Switching Characteristics for IEC61131-2 Type 1, 2, and 3 Proximity Switches

For a Type 2 switch application, two inputs are connected in parallel. The current limiters then add to a total maximum current of 7.2 mA. While the return-path (RE-pin), of one input might be used to drive an indicator LED, the RE-pin of the other input channel should be connected to ground (FGND).

Paralleling input channels reduces the number of available input channels from an octal Type 1 or Type 3 input to a quad Type 2 input device. Note, that in this configuration output data of an input channel is represented by two shift register bits.

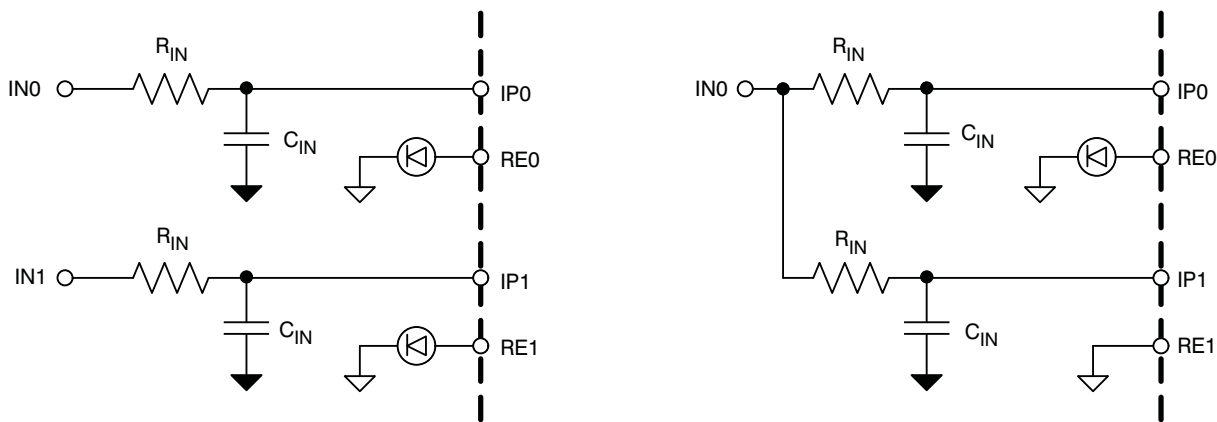

Figure 19. Paralleling Two Type 1 or Type 3 Inputs Into One Type 2 Input

9.1.3 Digital Interface Timing

The digital interface of the SN65HVS883 is SPI compatible and interfaces, isolated or non-isolated, to a wide variety of standard micro controllers.

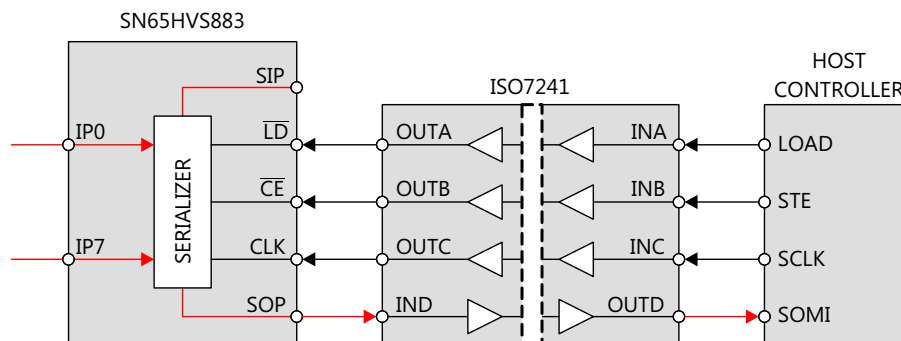

Figure 20. Simple Isolation of the Shift Register Interface

Upon a low-level at the load input, \overline{LD} , the information of the field inputs, IP0 to IP7 is latched into the shift register. Taking \overline{LD} high again blocks the parallel inputs of the shift register from the field inputs. A low-level at the clock-enable input, \overline{CE} , enables the clock signal, CLK, to serially shift the data to the serial output, SOP. Data is clocked into the shift register at the rising edge of CLK and out of the shift register on the falling edge of CLK. Thus after eight consecutive clock cycles all field input data have been clocked out of the shift register and the information of the serial input, SIP, appears at the serial output, SOP.

The \overline{CE} signal should only be transitioned low while the CLK signal is low which ensures that a rising edge of CLK occurs before a falling edge of CLK. This shifts the data into and through the shift register up until the final register before the first bit that was loaded into the final register is shifted out the serial output, SOP. If a falling edge of CLK is seen first following the transition of \overline{CE} to low, the final register outputs the first bit, IP0, on the serial output, SOP, before shifting the rest of the bits through the shift register. The previous value of the second to last register prior to the \overline{LD} event will then be shifted into the final register on the next rising CLK edge and output on the serial output, SOP, before the next valid bit, IP1, is output on the serial output, SOP. This appears as an erroneous bit in the serial data. Also, depending on how many falling CLK edges were seen before the \overline{CE} signal is transitioned back high, the final bit, IP7, may not get shifted out of the shift register.

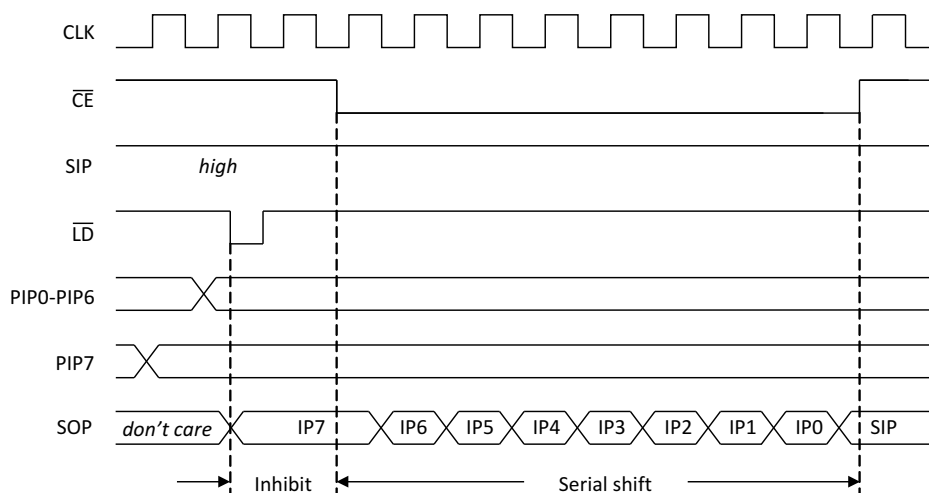

Figure 21. Interface Timing for Parallel-Load and Serial-Shift Operation of the Shift Register

9.1.4 Cascading for High Channel Count Input Modules

Designing high-channel count modules require cascading multiple SN65HVS883 devices. Simply connect the serial output (SOP) of a leading device with the serial input (SIP) of a following device without changing the processor interface.

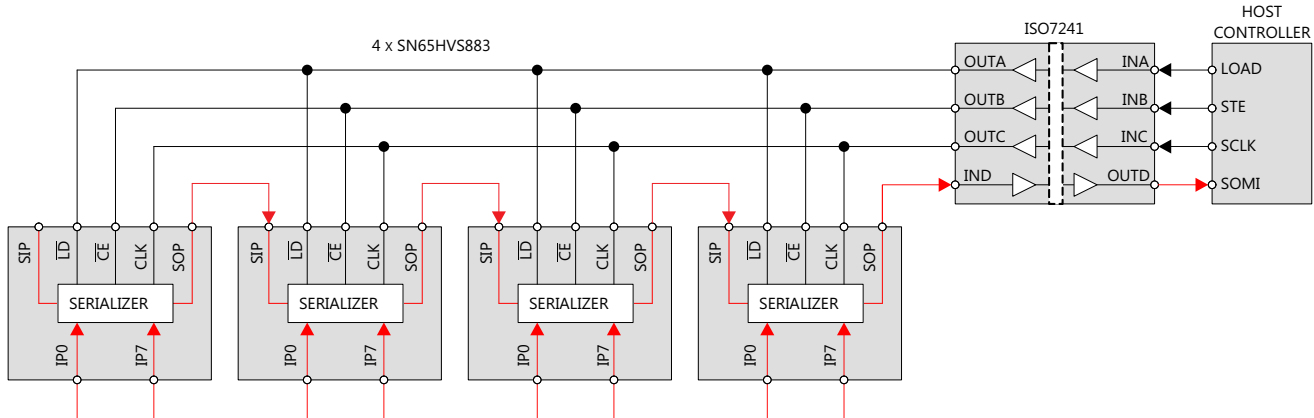
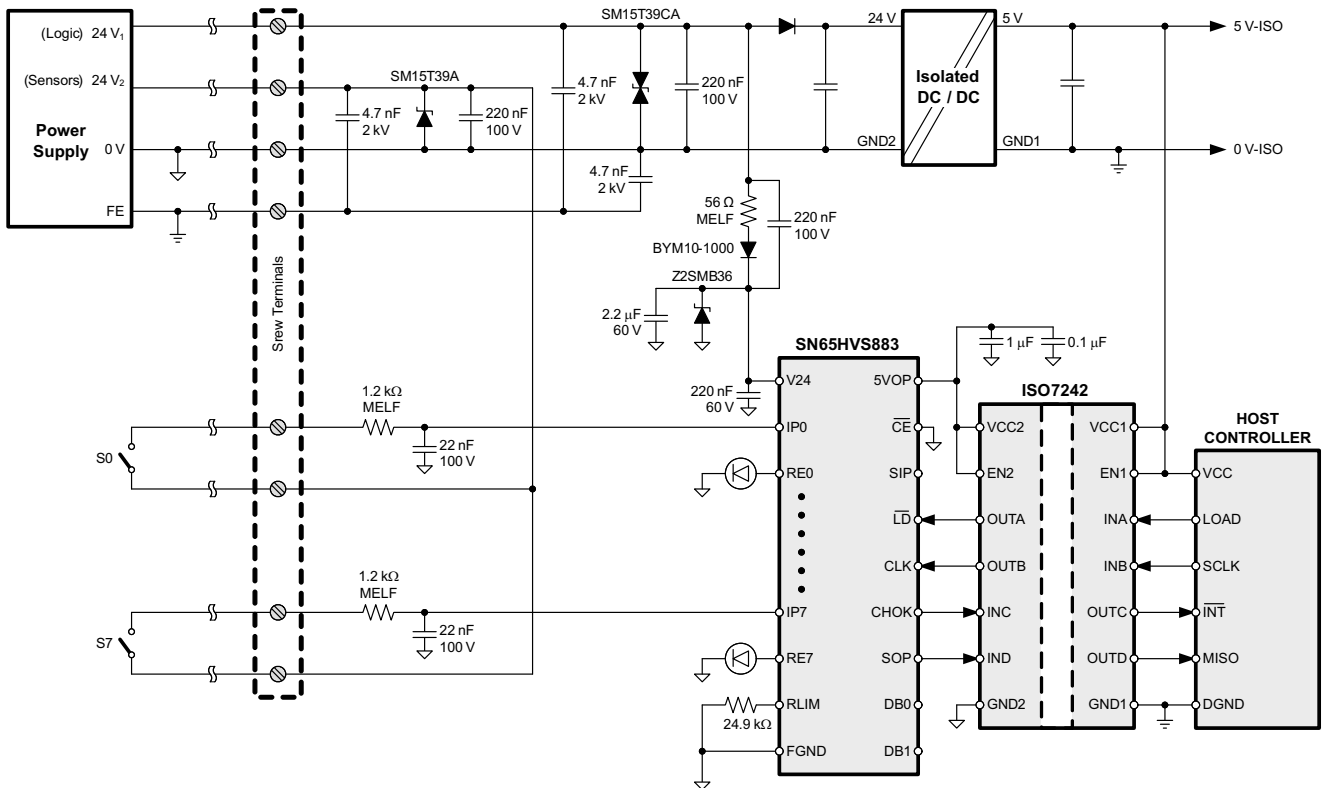

Figure 22. Cascading Four SN65HVS883 for a 32-Channel Input Module

NOTE

When daisy-chaining multiple devices, the maximum operating rate (CLK pulse width) may need to be restricted in order to maintain minimum set-up/hold timing relationships between the serial data (SIP/SOP) and the CLK line.

9.2 Typical Application



Copyright © 2016, Texas Instruments Incorporated

Figure 23. Typical Digital Input Module Application

Typical Application (continued)

9.2.1 Design Requirements

The simplified schematic in [Figure 23](#) demonstrates a typical application of the SN65HVS883 for sensing the state of digital switches with 24-V high logic levels. In this application, a 5-V host controller must receive the state of 8 switches as a serial input, while remaining isolated from the high voltage power supply.

9.2.2 Detailed Design Procedure

9.2.2.1 Input Stage

Selection of the current limiting resistor R_{LIM} sets the input current limit I_{LIM} for the device. [Digital Inputs](#) includes necessary equations for choosing the limiting resistor.

The On/Off voltage thresholds at the device pin $V_{TH(IP+)}$ and $V_{TH(IP-)}$ are fixed to 5.2 V and 4.3 V respectively, however the On/Off voltage thresholds of the field input $V_{TH(IN+)}$ and $V_{TH(IN-)}$ are determined by the value of the series resistor R_{IN} placed between the field input and the device. The threshold voltage $V_{TH(IN+)}$ is determined with the following equation:

$$V_{TH(IN+)} = I_{IN} \times R_{IN} + V_{TH(IP+)} \quad (3)$$

Substituting [Equation 1](#) and solving for R_{IN} produces an equation for R_{IN} given a desired on-threshold.

$$R_{IN} = \frac{(V_{TH(IN+)} - 5.2V) \times R_{LIM}}{90V} \quad (4)$$

The following equation can be used to calculate the off-threshold voltage given a value for R_{IN}

$$V_{TH(IN-)} = \frac{90V \times R_{IN}}{R_{LIM}} + V_{TH(IP-)} \quad (5)$$

[Figure 24](#) contains an example input characteristic:

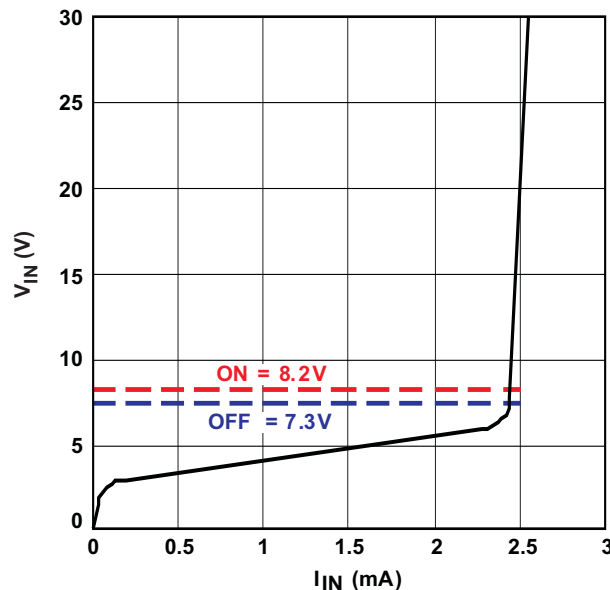

Figure 24. SN65HVS883 Example Input Characteristic

Typical Application (continued)

9.2.2.2 Setting Debounce Time

The logic signals at the DB0 and DB1 pins determine the denounce times for the device according to the table in section 6.5. The DB0 and DB1 pins are internally pulled high. Connecting the pins to GND in different configurations allows for selection of 0, 1, or 3 ms debounce times. In noisy environments, it is recommended that unused DB pins should be connected externally to a 5 V supply.

9.2.2.3 Example: High-Voltage Sensing Application

For the high-voltage sensing application in [Figure 23](#), inputs from each switch (S0-S7) are connected to the 8 parallel inputs (IP0-IP7) of the SN65HVS883 through 1.2 kΩ MELF resistors. Small capacitors (22 nF) are tied to ground at each input to provide noise protection for the signals. A resistor is added between the R_{LIM} pin and GND to provide a device current limit according to the equation $I_{LIM} = 90 \text{ V} / R_{LIM}$. In this example, with a 24.9 kΩ resistor, the current limit for the device is set to 3.6 mA. LEDs are placed between pins RE0-RE7 to allow for external status observation of the parallel inputs. Finally the SN65HVS883 is connected through a digital isolation device to the host controller to provide galvanic isolation to the external interfaces and to allow for communication between the 5 V SN65HVS883 logic and the 5-V host controller. The host controller manages mode switching and clocking of the SN65HVS883 through the digital isolation device.

9.2.3 Application Curve

The application traces acquired in [Figure 25](#) demonstrates the typical behavior of the SN65HVD883 when in shift mode (Load Pulse Input pulled high and Clock Enable Input pulled low). Channel 1 shows the SIP input, Channel 2 shows the CLK input, and Channel 3 shows the SOP output.

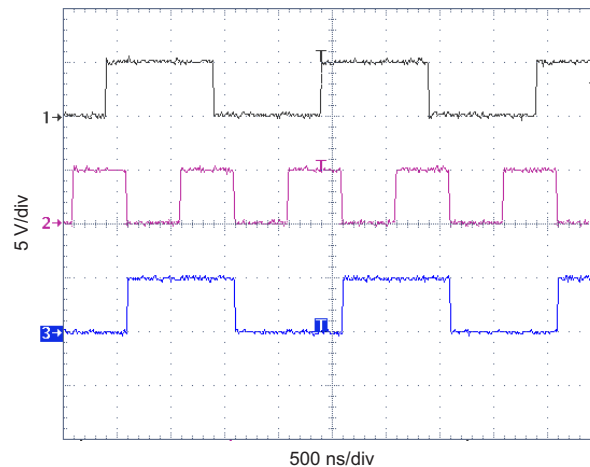

Figure 25. SN65HVS883 Serial Input and Output Timing

10 Power Supply Recommendations

The SN65HVS883 operates within a recommended supply voltage range from 4.5 V to 5.5 V. A 0.1 μF or larger capacitor should be placed between V_{CC} and ground to improve power supply noise immunity. A current limiting resistor can be used to reduce overall power consumption as described in [Digital Inputs](#). The high voltage parallel field inputs can accept voltages ranging from 0 V to 34 V, however all other inputs must remain between 0 V to 5 V. Refer to the [Recommended Operating Conditions](#) table for more detailed voltage suggestions. High voltage field inputs should be buffered as shown in [Figure 23](#) to improve input noise immunity.

11 Layout

11.1 Layout Guidelines

1. Place series MELF resistors between the field inputs and the device input pins.
2. Place small ~ 22 nF capacitors close to the field input pins to reduce noise.
3. Place a supply buffering 0.1- μF capacitor around as close to the V_{CC} pin as possible.

11.2 Layout Example

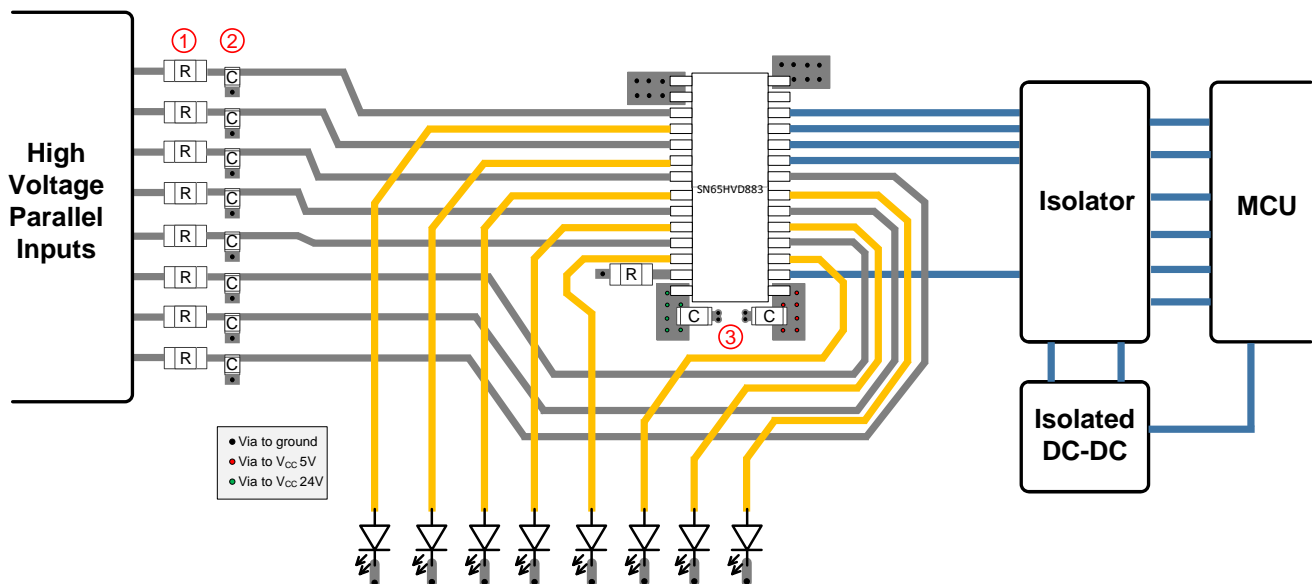

12 Device and Documentation Support

12.1 Third-Party Products Disclaimer

TI'S PUBLICATION OF INFORMATION REGARDING THIRD-PARTY PRODUCTS OR SERVICES DOES NOT CONSTITUTE AN ENDORSEMENT REGARDING THE SUITABILITY OF SUCH PRODUCTS OR SERVICES OR A WARRANTY, REPRESENTATION OR ENDORSEMENT OF SUCH PRODUCTS OR SERVICES, EITHER ALONE OR IN COMBINATION WITH ANY TI PRODUCT OR SERVICE.

12.2 Receiving Notification of Documentation Updates

To receive notification of documentation updates, navigate to the device product folder on ti.com. In the upper right corner, click on *Alert me* to register and receive a weekly digest of any product information that has changed. For change details, review the revision history included in any revised document.

12.3 Community Resources

The following links connect to TI community resources. Linked contents are provided "AS IS" by the respective contributors. They do not constitute TI specifications and do not necessarily reflect TI's views; see TI's [Terms of Use](#).

TI E2E™ Online Community *TI's Engineer-to-Engineer (E2E) Community*. Created to foster collaboration among engineers. At e2e.ti.com, you can ask questions, share knowledge, explore ideas and help solve problems with fellow engineers.

Design Support *TI's Design Support* Quickly find helpful E2E forums along with design support tools and contact information for technical support.

12.4 Trademarks

PowerPAD, E2E are trademarks of Texas Instruments.
All other trademarks are the property of their respective owners.

12.5 Electrostatic Discharge Caution



These devices have limited built-in ESD protection. The leads should be shorted together or the device placed in conductive foam during storage or handling to prevent electrostatic damage to the MOS gates.

12.6 Glossary

[SLYZ022](#) — *TI Glossary*.

This glossary lists and explains terms, acronyms, and definitions.

13 Mechanical, Packaging, and Orderable Information

The following pages include mechanical, packaging, and orderable information. This information is the most current data available for the designated devices. This data is subject to change without notice and revision of this document. For browser-based versions of this data sheet, refer to the left-hand navigation.

PACKAGING INFORMATION

Orderable Device	Status (1)	Package Type	Package Drawing	Pins	Package Qty	Eco Plan (2)	Lead/Ball Finish (6)	MSL Peak Temp (3)	Op Temp (°C)	Device Marking (4/5)	Samples
SN65HVS883PWP	ACTIVE	HTSSOP	PWP	28	50	Green (RoHS & no Sb/Br)	CU NIPDAU	Level-2-260C-1 YEAR	-40 to 85	HVS883	Samples
SN65HVS883PWPR	ACTIVE	HTSSOP	PWP	28	2000	Green (RoHS & no Sb/Br)	CU NIPDAU	Level-2-260C-1 YEAR	-40 to 85	HVS883	Samples

(1) The marketing status values are defined as follows:

ACTIVE: Product device recommended for new designs.

LIFEBUY: TI has announced that the device will be discontinued, and a lifetime-buy period is in effect.

NRND: Not recommended for new designs. Device is in production to support existing customers, but TI does not recommend using this part in a new design.

PREVIEW: Device has been announced but is not in production. Samples may or may not be available.

OBSELETE: TI has discontinued the production of the device.

(2) Eco Plan - The planned eco-friendly classification: Pb-Free (RoHS), Pb-Free (RoHS Exempt), or Green (RoHS & no Sb/Br) - please check <http://www.ti.com/productcontent> for the latest availability information and additional product content details.

TBD: The Pb-Free/Green conversion plan has not been defined.

Pb-Free (RoHS): TI's terms "Lead-Free" or "Pb-Free" mean semiconductor products that are compatible with the current RoHS requirements for all 6 substances, including the requirement that lead not exceed 0.1% by weight in homogeneous materials. Where designed to be soldered at high temperatures, TI Pb-Free products are suitable for use in specified lead-free processes.

Pb-Free (RoHS Exempt): This component has a RoHS exemption for either 1) lead-based flip-chip solder bumps used between the die and package, or 2) lead-based die adhesive used between the die and leadframe. The component is otherwise considered Pb-Free (RoHS compatible) as defined above.

Green (RoHS & no Sb/Br): TI defines "Green" to mean Pb-Free (RoHS compatible), and free of Bromine (Br) and Antimony (Sb) based flame retardants (Br or Sb do not exceed 0.1% by weight in homogeneous material)

(3) MSL, Peak Temp. - The Moisture Sensitivity Level rating according to the JEDEC industry standard classifications, and peak solder temperature.

(4) There may be additional marking, which relates to the logo, the lot trace code information, or the environmental category on the device.

(5) Multiple Device Markings will be inside parentheses. Only one Device Marking contained in parentheses and separated by a "~" will appear on a device. If a line is indented then it is a continuation of the previous line and the two combined represent the entire Device Marking for that device.

(6) Lead/Ball Finish - Orderable Devices may have multiple material finish options. Finish options are separated by a vertical ruled line. Lead/Ball Finish values may wrap to two lines if the finish value exceeds the maximum column width.

Important Information and Disclaimer:The information provided on this page represents TI's knowledge and belief as of the date that it is provided. TI bases its knowledge and belief on information provided by third parties, and makes no representation or warranty as to the accuracy of such information. Efforts are underway to better integrate information from third parties. TI has taken and continues to take reasonable steps to provide representative and accurate information but may not have conducted destructive testing or chemical analysis on incoming materials and chemicals. TI and TI suppliers consider certain information to be proprietary, and thus CAS numbers and other limited information may not be available for release.

In no event shall TI's liability arising out of such information exceed the total purchase price of the TI part(s) at issue in this document sold by TI to Customer on an annual basis.

MECHANICAL DATA

PWP (R-PDSO-G28)

PowerPAD™ PLASTIC SMALL OUTLINE

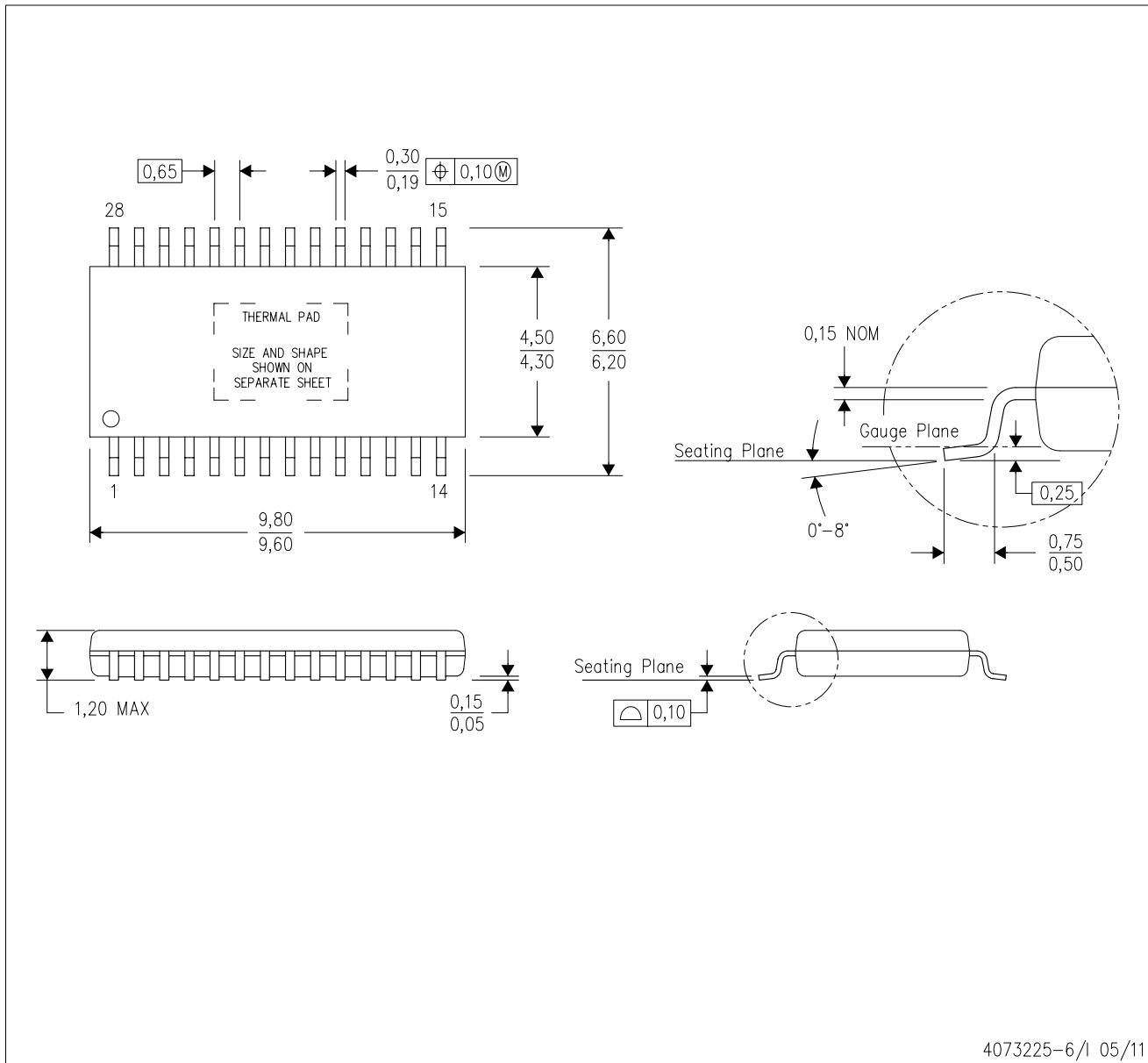

4073225-6/1 05/11

- NOTES:
- All linear dimensions are in millimeters.
 - This drawing is subject to change without notice.
 - Body dimensions do not include mold flash or protrusions. Mold flash and protrusion shall not exceed 0.15 per side.
 - This package is designed to be soldered to a thermal pad on the board. Refer to Technical Brief, PowerPad Thermally Enhanced Package, Texas Instruments Literature No. SLMA002 for information regarding recommended board layout. This document is available at www.ti.com <<http://www.ti.com>>.
 - See the additional figure in the Product Data Sheet for details regarding the exposed thermal pad features and dimensions.
 - Falls within JEDEC MO-153

PowerPAD is a trademark of Texas Instruments.

THERMAL PAD MECHANICAL DATA

PWP (R-PDSO-G28) PowerPAD™ SMALL PLASTIC OUTLINE

THERMAL INFORMATION

This PowerPAD™ package incorporates an exposed thermal pad that is designed to be attached to a printed circuit board (PCB). The thermal pad must be soldered directly to the PCB. After soldering, the PCB can be used as a heatsink. In addition, through the use of thermal vias, the thermal pad can be attached directly to the appropriate copper plane shown in the electrical schematic for the device, or alternatively, can be attached to a special heatsink structure designed into the PCB. This design optimizes the heat transfer from the integrated circuit (IC).

For additional information on the PowerPAD package and how to take advantage of its heat dissipating abilities, refer to Technical Brief, PowerPAD Thermally Enhanced Package, Texas Instruments Literature No. SLMA002 and Application Brief, PowerPAD Made Easy, Texas Instruments Literature No. SLMA004. Both documents are available at www.ti.com.

The exposed thermal pad dimensions for this package are shown in the following illustration.



Top View

Exposed Thermal Pad Dimensions

4206332-33/AO 01/16

NOTE: A. All linear dimensions are in millimeters
B. Exposed tie strap features may not be present.

PowerPAD is a trademark of Texas Instruments

PWP (R-PDSO-G28)

PowerPAD™ PLASTIC SMALL OUTLINE

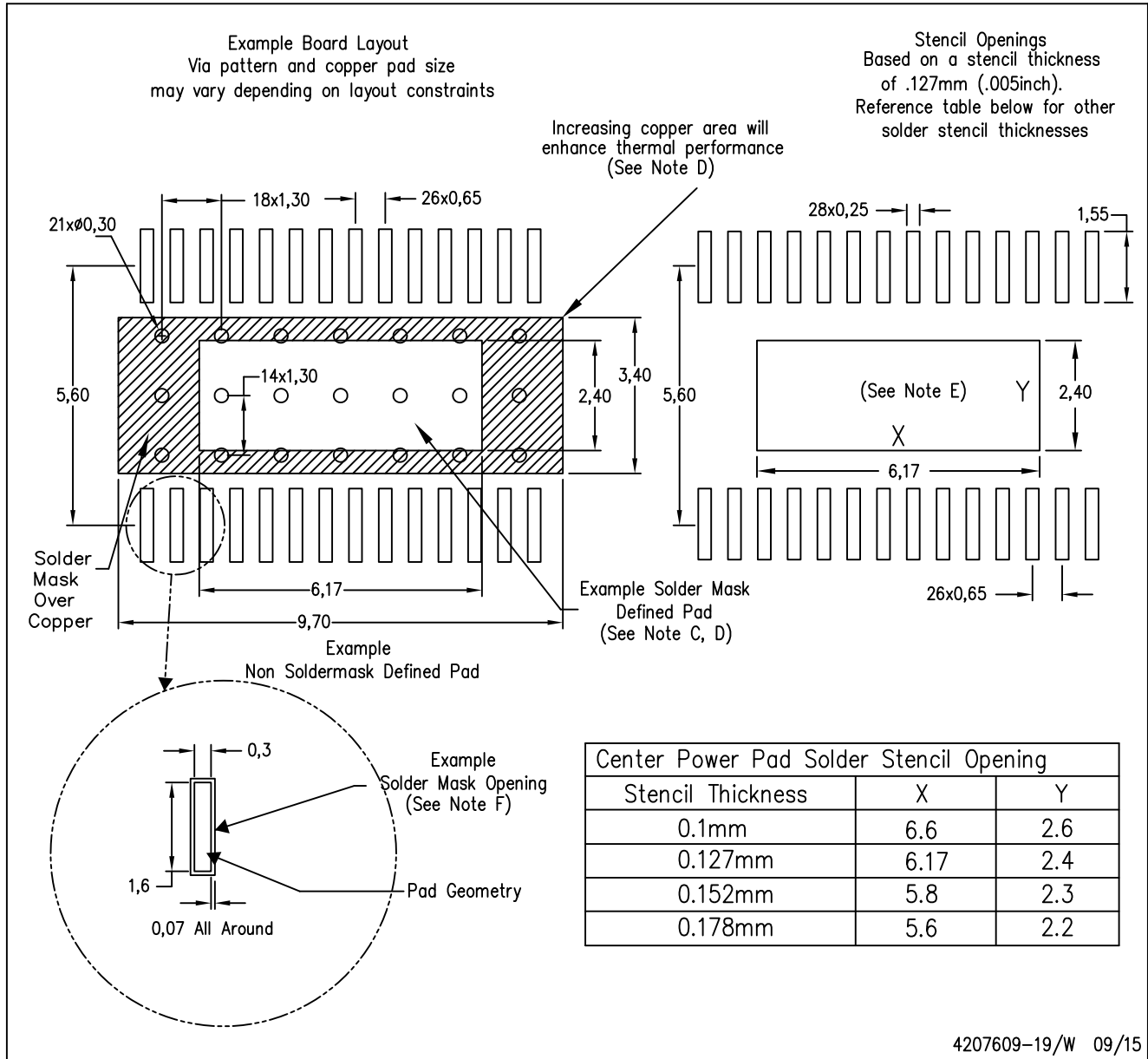

- NOTES:
- All linear dimensions are in millimeters.
 - This drawing is subject to change without notice.
 - Customers should place a note on the circuit board fabrication drawing not to alter the center solder mask defined pad.
 - This package is designed to be soldered to a thermal pad on the board. Refer to Technical Brief, PowerPad Thermally Enhanced Package, Texas Instruments Literature No. SLMA002, SLMA004, and also the Product Data Sheets.
 - For specific thermal information, via requirements, and recommended board layout. These documents are available at www.ti.com <<http://www.ti.com>>. Publication IPC-7351 is recommended for alternate designs. Laser cutting apertures with trapezoidal walls and also rounding corners will offer better paste release. Customers should contact their board assembly site for stencil design recommendations. Example stencil design based on a 50% volumetric metal load solder paste. Refer to IPC-7525 for other stencil
 - Customers should contact their board fabrication site for solder mask tolerances between and around signal pads.

IMPORTANT NOTICE

Texas Instruments Incorporated and its subsidiaries (TI) reserve the right to make corrections, enhancements, improvements and other changes to its semiconductor products and services per JESD46, latest issue, and to discontinue any product or service per JESD48, latest issue. Buyers should obtain the latest relevant information before placing orders and should verify that such information is current and complete. All semiconductor products (also referred to herein as "components") are sold subject to TI's terms and conditions of sale supplied at the time of order acknowledgment.

TI warrants performance of its components to the specifications applicable at the time of sale, in accordance with the warranty in TI's terms and conditions of sale of semiconductor products. Testing and other quality control techniques are used to the extent TI deems necessary to support this warranty. Except where mandated by applicable law, testing of all parameters of each component is not necessarily performed.

TI assumes no liability for applications assistance or the design of Buyers' products. Buyers are responsible for their products and applications using TI components. To minimize the risks associated with Buyers' products and applications, Buyers should provide adequate design and operating safeguards.

TI does not warrant or represent that any license, either express or implied, is granted under any patent right, copyright, mask work right, or other intellectual property right relating to any combination, machine, or process in which TI components or services are used. Information published by TI regarding third-party products or services does not constitute a license to use such products or services or a warranty or endorsement thereof. Use of such information may require a license from a third party under the patents or other intellectual property of the third party, or a license from TI under the patents or other intellectual property of TI.

Reproduction of significant portions of TI information in TI data books or data sheets is permissible only if reproduction is without alteration and is accompanied by all associated warranties, conditions, limitations, and notices. TI is not responsible or liable for such altered documentation. Information of third parties may be subject to additional restrictions.

Resale of TI components or services with statements different from or beyond the parameters stated by TI for that component or service voids all express and any implied warranties for the associated TI component or service and is an unfair and deceptive business practice. TI is not responsible or liable for any such statements.

Buyer acknowledges and agrees that it is solely responsible for compliance with all legal, regulatory and safety-related requirements concerning its products, and any use of TI components in its applications, notwithstanding any applications-related information or support that may be provided by TI. Buyer represents and agrees that it has all the necessary expertise to create and implement safeguards which anticipate dangerous consequences of failures, monitor failures and their consequences, lessen the likelihood of failures that might cause harm and take appropriate remedial actions. Buyer will fully indemnify TI and its representatives against any damages arising out of the use of any TI components in safety-critical applications.

In some cases, TI components may be promoted specifically to facilitate safety-related applications. With such components, TI's goal is to help enable customers to design and create their own end-product solutions that meet applicable functional safety standards and requirements. Nonetheless, such components are subject to these terms.

No TI components are authorized for use in FDA Class III (or similar life-critical medical equipment) unless authorized officers of the parties have executed a special agreement specifically governing such use.

Only those TI components which TI has specifically designated as military grade or "enhanced plastic" are designed and intended for use in military/aerospace applications or environments. Buyer acknowledges and agrees that any military or aerospace use of TI components which have **not** been so designated is solely at the Buyer's risk, and that Buyer is solely responsible for compliance with all legal and regulatory requirements in connection with such use.

TI has specifically designated certain components as meeting ISO/TS16949 requirements, mainly for automotive use. In any case of use of non-designated products, TI will not be responsible for any failure to meet ISO/TS16949.

Products

Audio	www.ti.com/audio
Amplifiers	amplifier.ti.com
Data Converters	dataconverter.ti.com
DLP® Products	www.dlp.com
DSP	dsp.ti.com
Clocks and Timers	www.ti.com/clocks
Interface	interface.ti.com
Logic	logic.ti.com
Power Mgmt	power.ti.com
Microcontrollers	microcontroller.ti.com
RFID	www.ti-rfid.com
OMAP Applications Processors	www.ti.com/omap
Wireless Connectivity	www.ti.com/wirelessconnectivity

Applications

Automotive and Transportation	www.ti.com/automotive
Communications and Telecom	www.ti.com/communications
Computers and Peripherals	www.ti.com/computers
Consumer Electronics	www.ti.com/consumer-apps
Energy and Lighting	www.ti.com/energy
Industrial	www.ti.com/industrial
Medical	www.ti.com/medical
Security	www.ti.com/security
Space, Avionics and Defense	www.ti.com/space-avionics-defense
Video and Imaging	www.ti.com/video

TI E2E Community

e2e.ti.com