

25-07235

- 1 MATERIAL: HEADER-THERMOPLASTIC POLYESTER
GLASS-FILLED 94V-0 (NATURAL)
POST-COPPER ALLOY
- 2 FINISH: CONTACT-TIN PLATE
- 3 PARTS COMPLY WITH AMP SOLDERABILITY SPEC. NO. 109-11-12.
- 4 SPECIAL PACKAGING VARIATION FOR IMPROVED PRODUCT PROTECTION

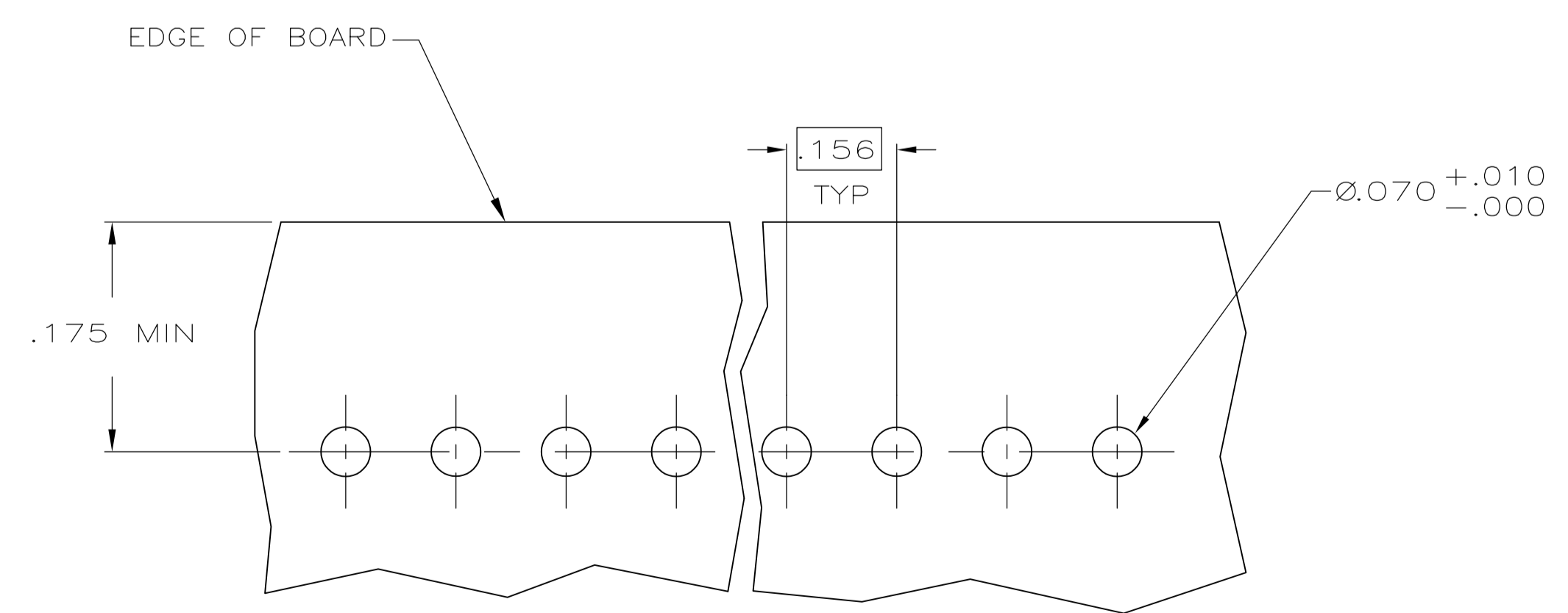
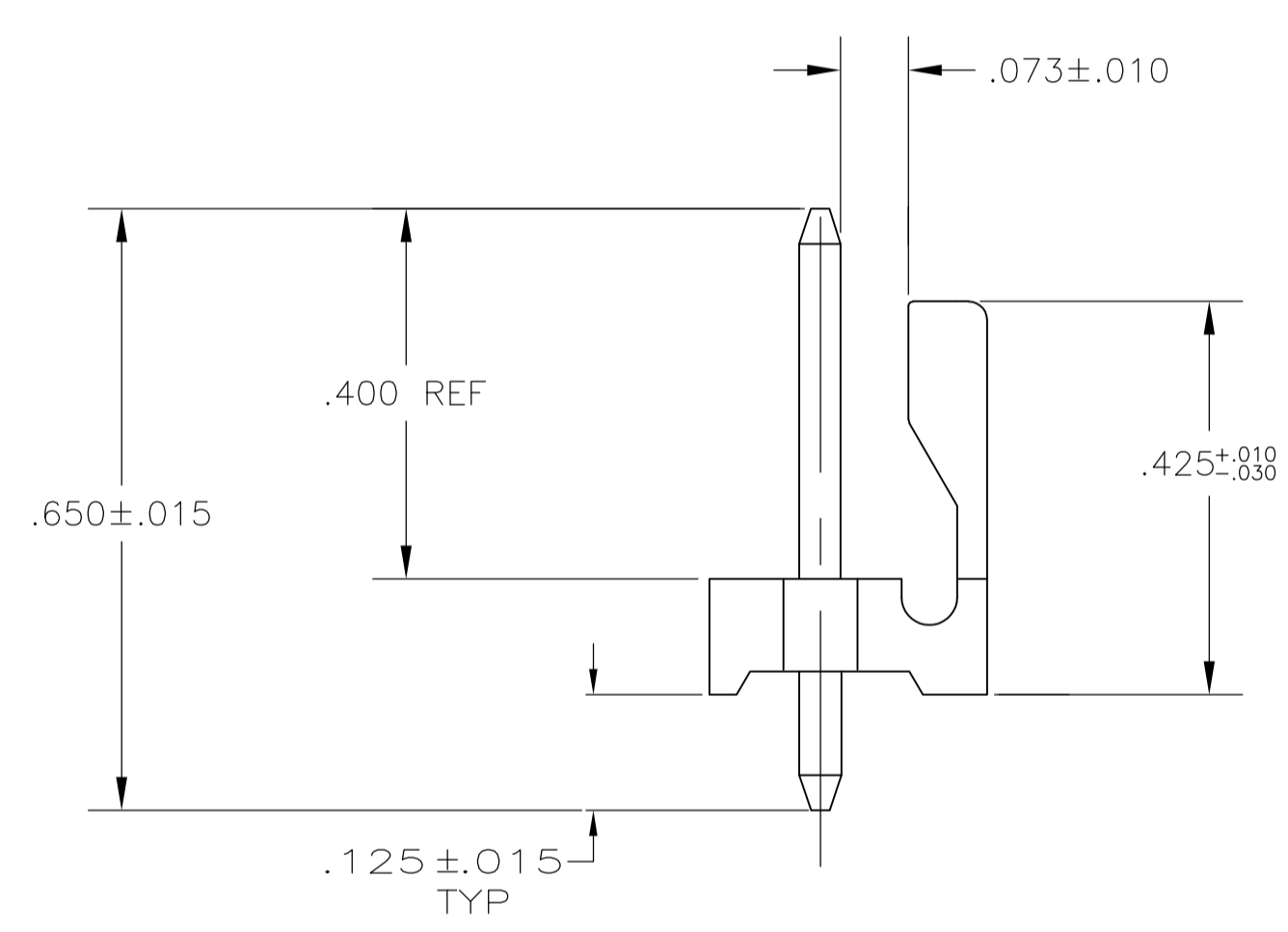
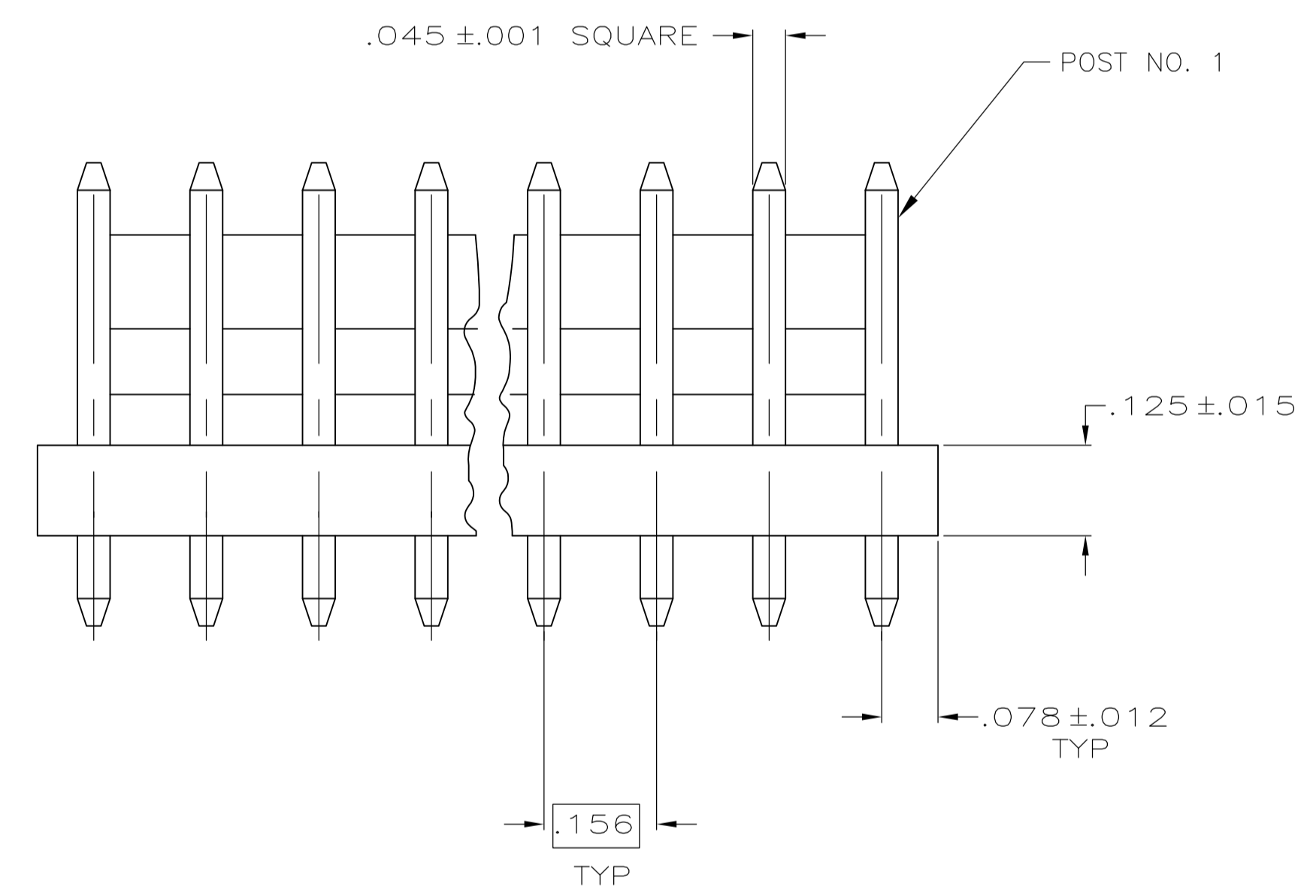
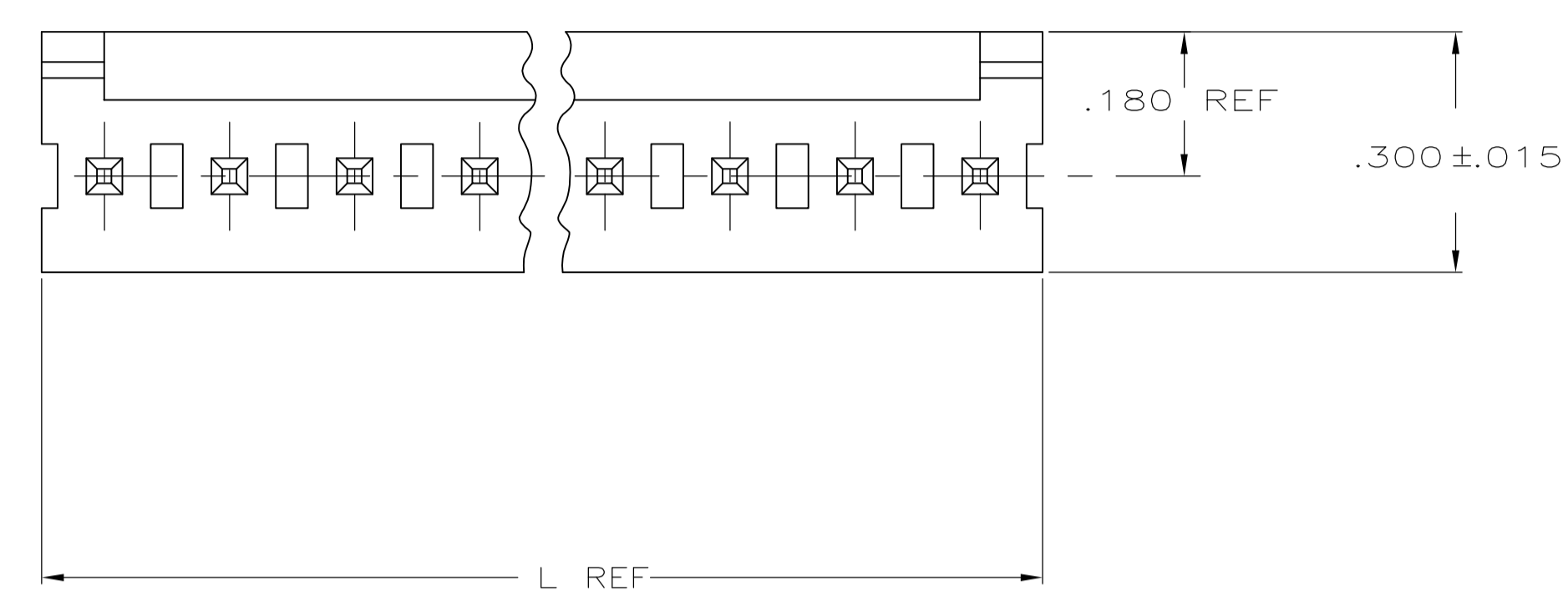

RECOMMENDED MOUNTING HOLE PATTERN FOR .063 THICK P.C. BOARD

31.70	1.248	8	3-640445-8
95.10	3.744	24	2-640445-4
91.14	3.588	23	2-640445-3
87.17	3.432	22	2-640445-2
83.21	3.276	21	2-640445-1
79.25	3.120	20	2-640445-0
75.29	2.964	19	1-640445-9
71.32	2.808	18	1-640445-8
67.36	2.652	17	1-640445-7
63.40	2.496	16	1-640445-6
59.44	2.340	15	1-640445-5
55.47	2.184	14	1-640445-4
51.51	2.028	13	1-640445-3
47.55	1.872	12	1-640445-2
43.59	1.716	11	1-640445-1
39.62	1.560	10	1-640445-0
35.66	1.404	9	640445-9
31.70	1.248	8	640445-8
27.74	1.092	7	640445-7
23.77	.936	6	640445-6
19.81	.780	5	640445-5
15.85	.624	4	640445-4
11.89	.468	3	640445-3
7.92	.312	2	640445-2
MM	[IN]	NUMBER OF POSITIONS	PART NUMBER

THIS DRAWING IS A CONTROLLED DOCUMENT.

DIMENSIONS: INCHES	TOLERANCES UNLESS OTHERWISE SPECIFIED:	DIN S. HOOVER 05-NOV-2002	APPROVED D. ROSSI 05-NOV-2002
0 PLC ±	1 PLC ±	2 PLC ±	3 PLC ±
4 PLC ±	ANGLES ±	APPLIC. SPEC	SIZE: A1
MATERIAL: 1	FINISH: 2	WEIGHT: 00779	CAGE CODE: 640445
CUSTOMER DRAWING		SCALE: 5:1	SHEET 1 OF 1 REV AD3

STE TE Connectivity
MTA-156 HEADER ASSEMBLY, FRICTION LOCK, STRAIGHT .045 SQUARE POST, TIN PLATED