

25-07168

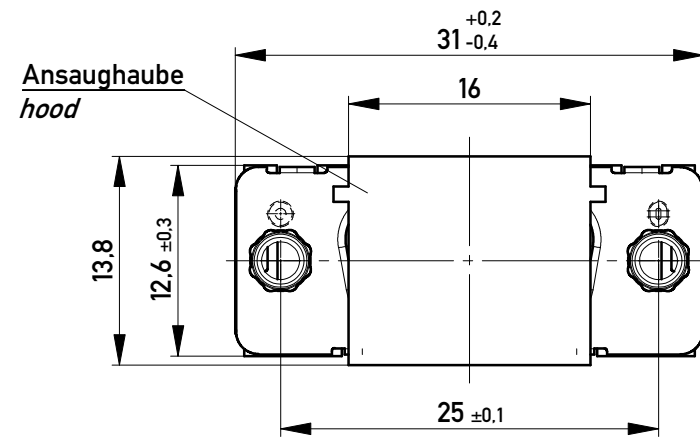

ohne / without

Mutter / nut

max. Einschraubtiefe 5.0 mm
thread depth max. 5.0 mm

Bolzen / bolt

max. Einschraubtiefe 5.5 mm
thread depth max. 5.5 mm

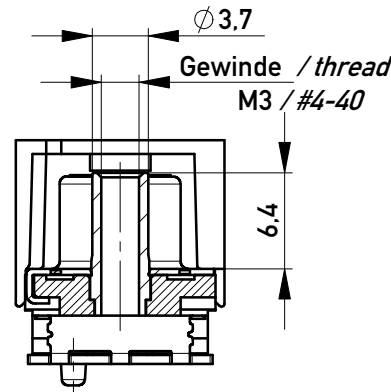
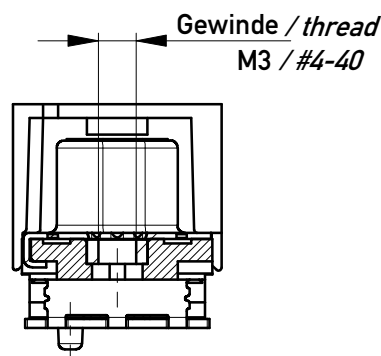
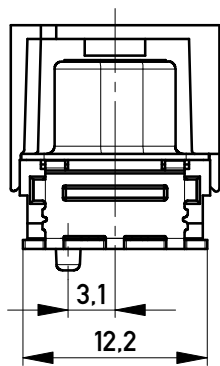

Beschriftung nach Bedruckungsvorschrift 174538
Part marking according to specification 174538

194270	174389	X			
194271	204264			#4-40	
194272	164025			M3	
194273	164021		#4-40		
194274	164017		M3		
Ident.-Nr. part-no. tape & reel	Ident.-Nr. part-no. tray	ohne without	Mutter thread	Bolzen bolt	Bemerkung remark

M 1:1

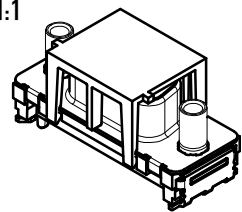

Anschlussbereich verzinkt
terminal area tin plating

Koplanarität der Anschlüsse ≤ 0,1 mm
coplanarity area of termination ≤ 0,1 mm

Anforderungsstufe: 2
class: 2

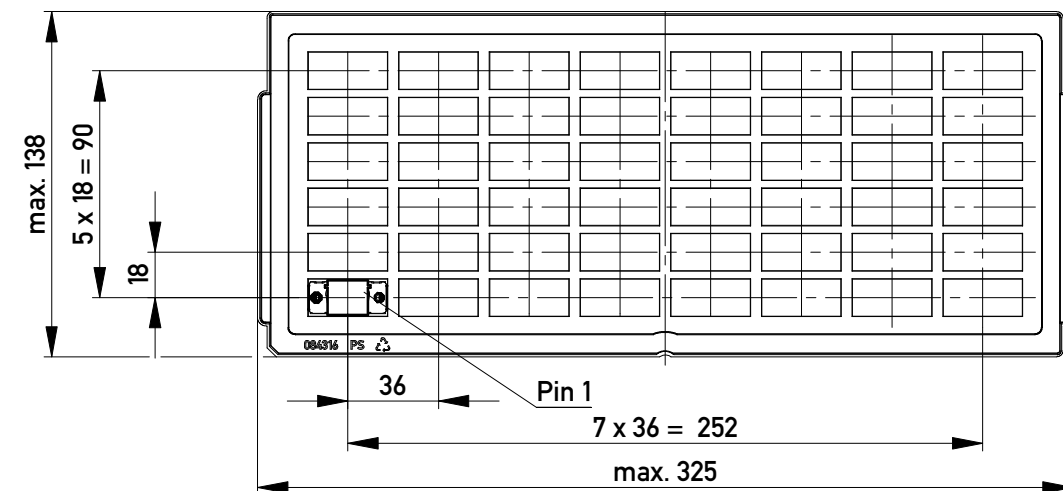

Verpackt in Tray
Verpackungseinheit 48 St.
tray packaging
packaging unit 48 pcs

Sonstige Angaben siehe Zeichnung 204628 / Additional indications according to drawing 204628

Verpackt in Gurtverpackung - Tape on Reel Packaging
Verpackungseinheit: 120 Stück - Packaging unit: 120 pcs

Abspulrichtung - Reel off Direction

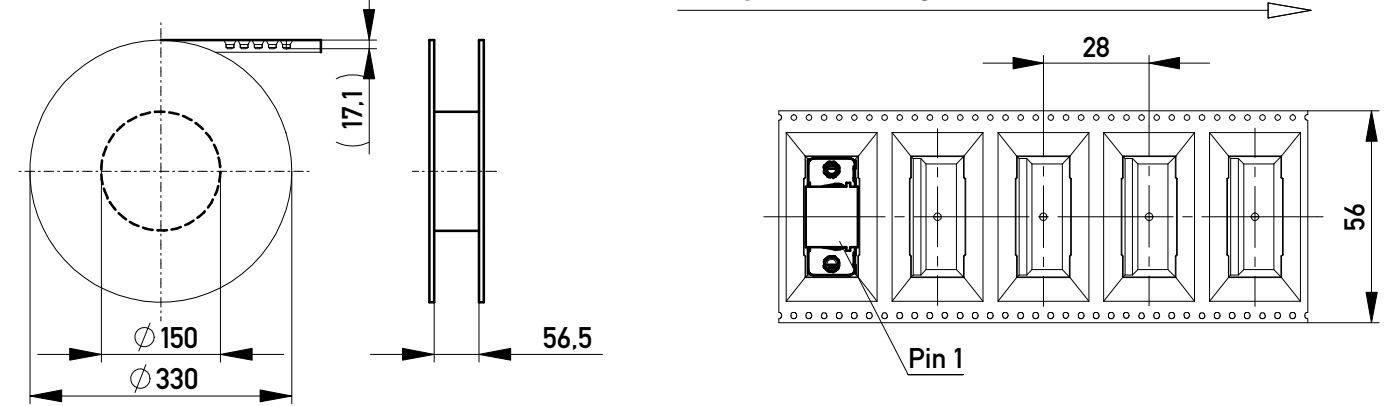

Sonstige Angaben siehe Zeichnung 204654 / Additional indications according to drawing 204654

Layoutvorschlag:
recommended layout:

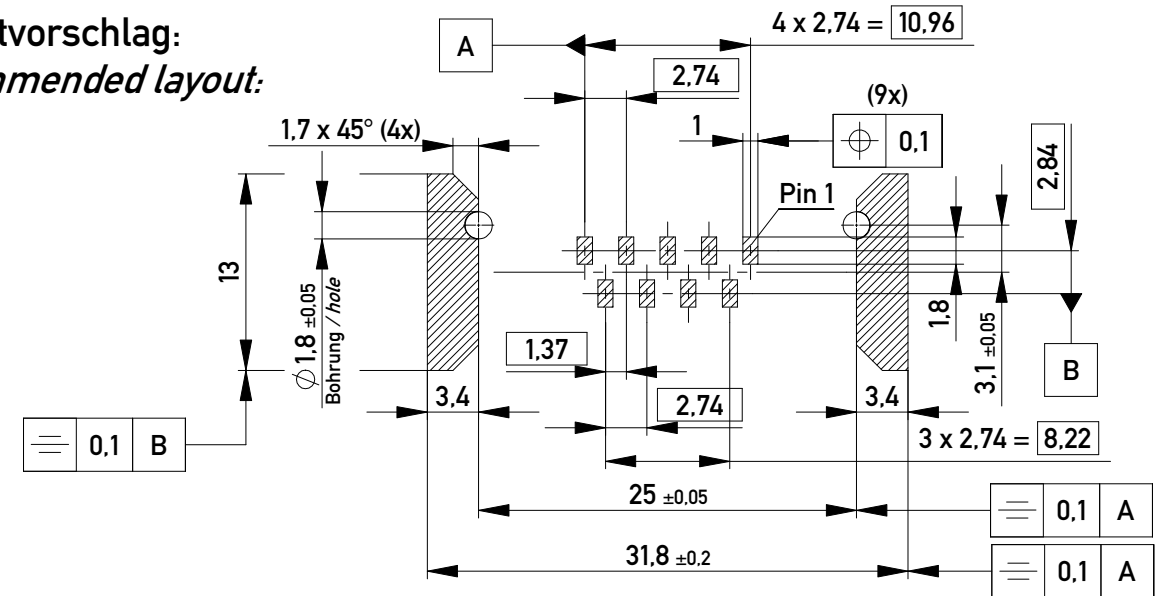

Fehlende Masse und Angaben siehe DIN 41652 / Missing information and dimensions according to DIN 41652
Sonstige Angaben siehe Fertigungsunterlagen / Additional indications please see the production documentation

Information:	Tolerances	Scale	2:1
All rights reserved. Only for Information. To ensure that this is the latest version of this drawing, please contact one of the ERNI companies before using.	Subject to modification without prior notice. Drawing will not be updated.	Designation	
		TMC-S 09-SMD-6,3-BA8 TMC-S 09-SMD-6,3-type 8	
www.ERNI.com	144893	I	
Class	TMCS	A3	

Copyright by ERNI GmbH
Proprietary notice pursuant to ISO 16016 to be observed.

f	19.04.2010
Index	Date