

25-07105

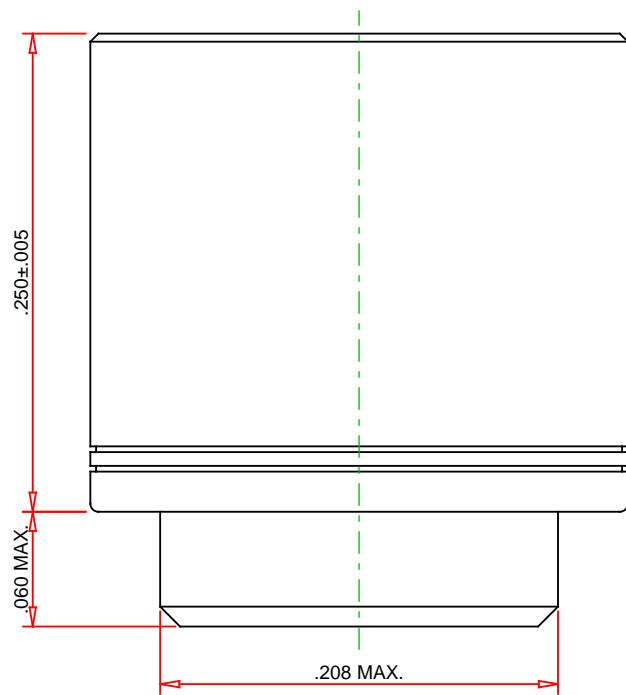
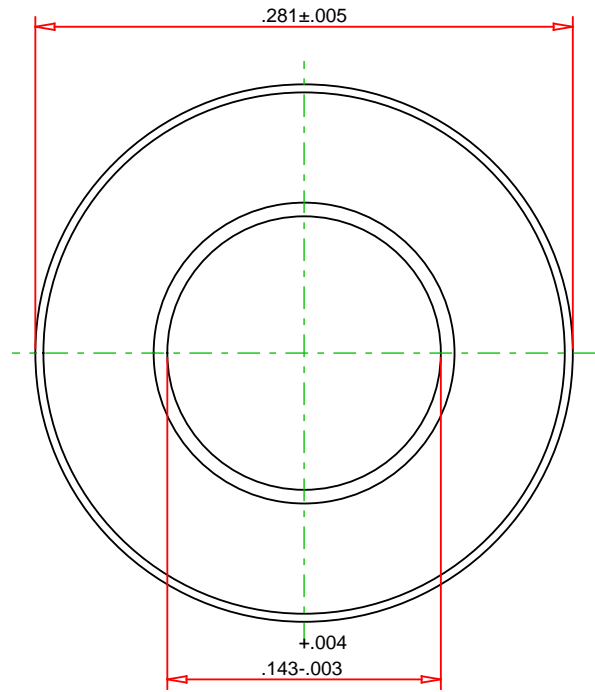
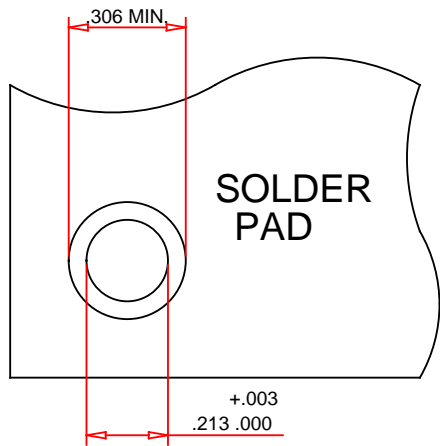

© 2015 PennEngineering

ALL DIMENSIONS IN INCHES

DATE 4-AUG-2015

NOTE : DRAWING NOT TO SCALE

THREAD :	A	MOUNTING HOLE DIA. :	.213 +.003 -.000
MATERIAL:	STEEL	PANEL THICKNESS:	.060 MINIMUM
HEAT TREAT:	NONE	MAX. PANEL HARDNESS:	NOT APPLICABLE
FINISH:	ELECTRO-PLATED BRIGHT TIN WITH CLEAR PRESERVATIVE COATING	MIN CENTERLINE-TO-EDGE:	NOT APPLICABLE
DESCRIPTION :	REELFAST® SURFACE MOUNT STANDOFFS - TYPE SMTSO - UNIFIED		
PART NO. :	SMTSO-143-8ET		



PennEngineering®

EMAIL: TECHSUPPORT@PEMNET.COM
WWW.PEMNET.COM