

26-07061

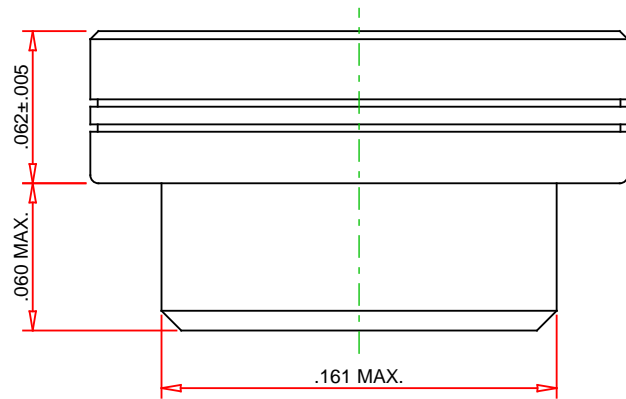
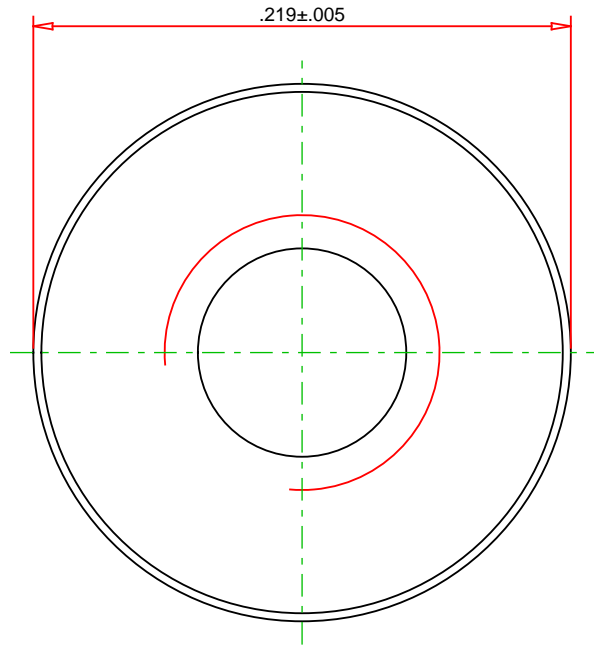
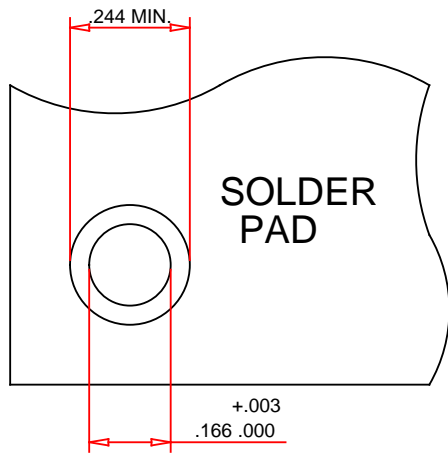

© 2015 PennEngineering

ALL DIMENSIONS IN INCHES

DATE 31-MAR-2015

NOTE : DRAWING NOT TO SCALE

THREAD : .112-40 (#4-40)

MOUNTING HOLE DIA. : .166 +.003 -.000

MATERIAL: STEEL

PANEL THICKNESS: .060 MINIMUM

HEAT TREAT: NONE

MAX. PANEL HARDNESS: NOT APPLICABLE

FINISH: ELECTRO-PLATED BRIGHT TIN WITH CLEAR PRESERVATIVE COATING

MIN CENTERLINE-TO-EDGE: NOT APPLICABLE

DESCRIPTION :  
REELFAST® SURFACE MOUNT STANDOFFS - TYPE SMTSO - UNIFIED



PennEngineering®

PART NO. :

EMAIL: TECHSUPPORT@PEMNET.COM

SMTSO-440-2ET

WWW.PEMNET.COM