

DESCRIPTION: 0.625 CENTER DUAL PORT D-SUB - FEMALE OVER MALE

25 PIN SHOWN

DIMENSIONS (IN.)				
	9	15	25	37
A	1.204	1.535	2.078	2.724
B	0.984	1.312	1.850	2.500
C	0.494	0.494	0.494	0.494

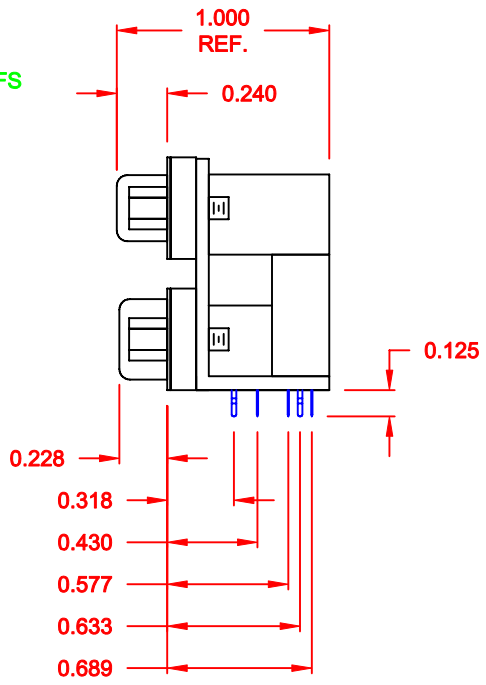
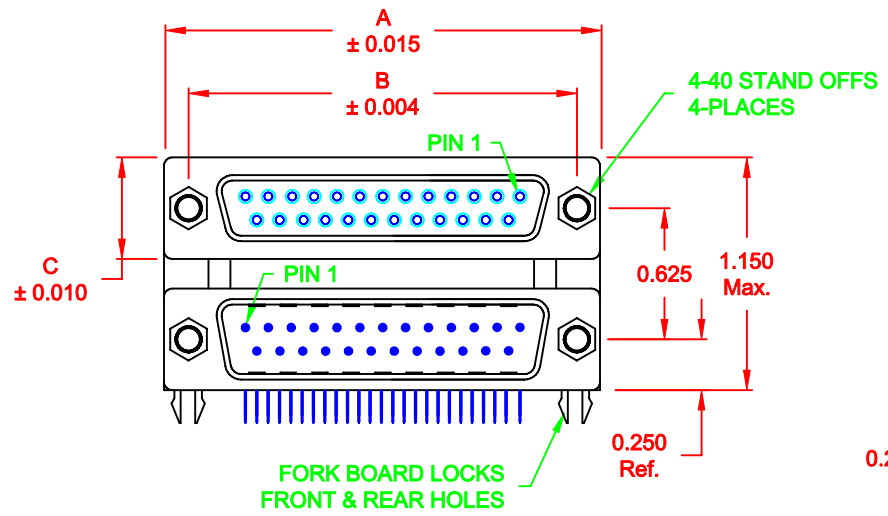

SPECIFICATION:

MATERIAL:
 SHELL: STEEL, NICKEL PLATED
 INSULATOR: UL 94V-0 RATED, BLACK PA9T, 260° PROCESS TEMP.
 CONTACTS: BRASS
 CONTACT PLATING: GOLD PLATED ENTIRE CONTACT

ELECTRICAL:
 INSULATOR RESISTANCE: 1,000 Ohms Min.
 DIELECTRIC STRENGTH: 1,000VAC RMS
 CURRENT RATING: 5 AMPS
 OPERATING TEMPERATURE: -55° C TO 105° C

189-YYY-313R571

SERIES _____
 POSITIONS _____
 009
 015
 025
 037
 GENDER _____
 31 = FEMALE OVER MALE
 41 = MALE OVER FEMALE
 51 = FEMALE OVER FEMALE
 61 = MALE OVER MALE
 SHELL PLATING _____
 3 = NICKEL
 RoHS COMPLIANT (HIGH TEMP. PROCESS) _____
 HARDWARE OPTIONS _____
 57 = 4-40 STAND OFFS/BOARD LOCKS
 PLATING OPTIONS _____
 1 = GOLD FLASH

DO NOT SCALE FROM DRAWING

	THESE DRAWINGS AND SPECIFICATIONS ARE THE PROPERTY OF NorComp AND SHALL NOT BE REPRODUCED, COPIED OR USED AS THE BASIS FOR THE MANUFACTURE OR SALE OF APPARATUS WITHOUT WRITTEN PERMISSION.	DRAWN: C. SMITH CHECKED:	DATE: 03-30-07 DATE:
	NorComp	SCALE: 1:1 DWG NO. 189-YYY-313R571	SHEET 1 OF 1 REV 4

RoHS COMPLIANT