

25-06375  
D15P33E4GV00LF

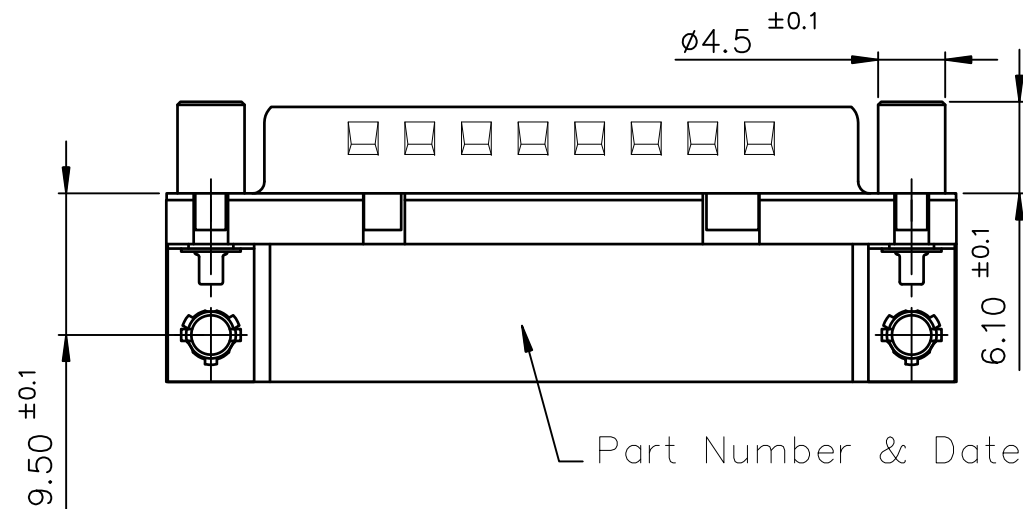

Part Number & Date Code Printing

PC card drilling dimensions(after plating)  
(thickness 1.60±0.20mm)

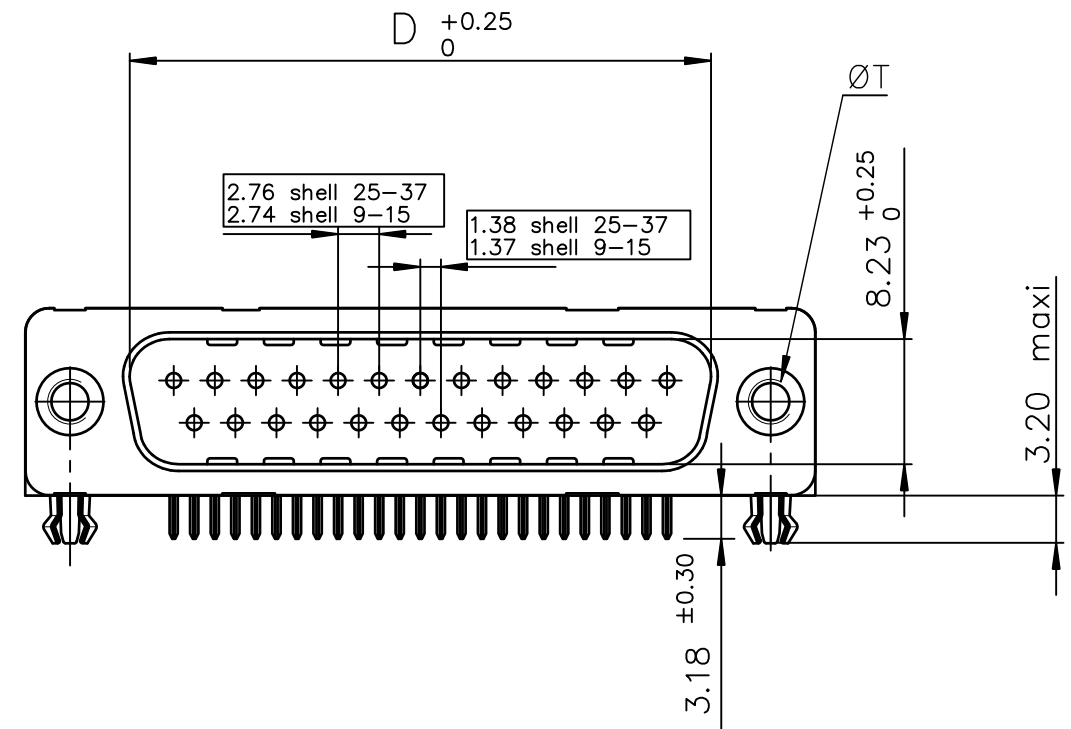
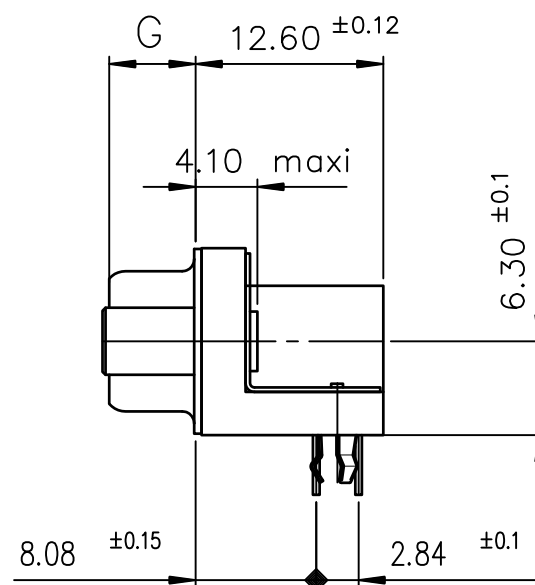
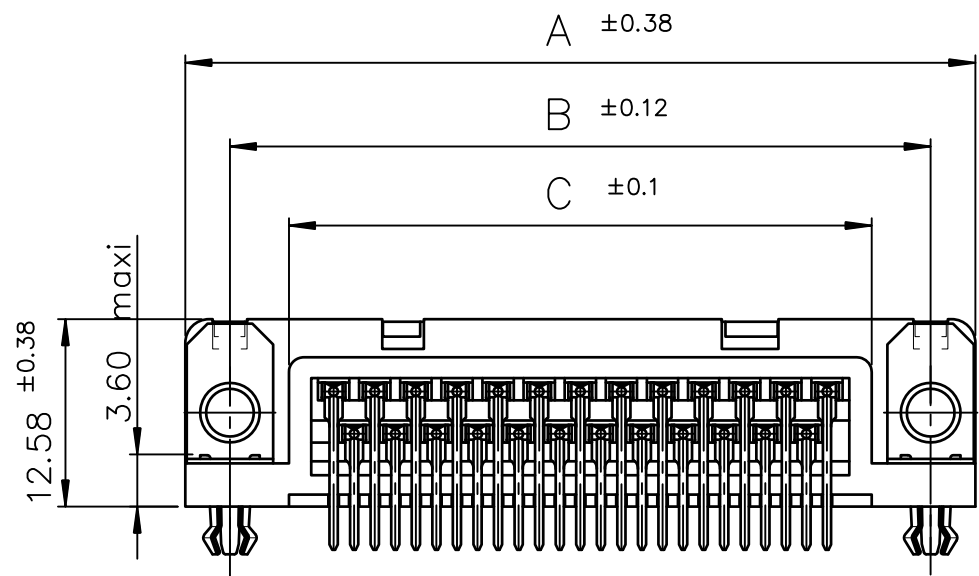
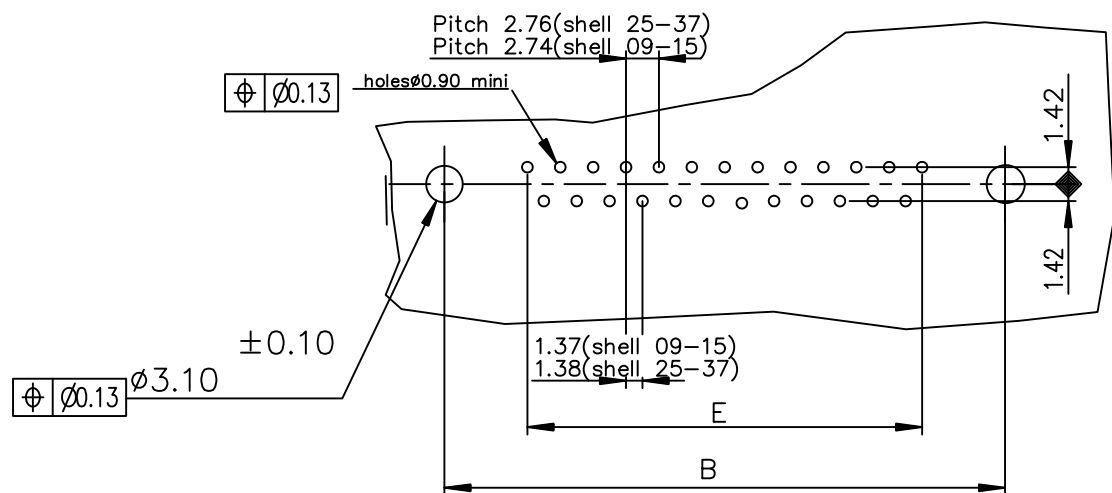

TIN LEAD PART NUMBER										
SHELL	A±0.38	B±0.12	C±0.10	D±0.25	E±0.07	G±0.25	200 Mating cycles	500 Mating cycles		
09	30.81	24.99	16.96	16.79	10.96	5.90	D09P33E4GV00	D09P33E4GI00	D09P33E6GV00	D09P33E6GI00
15	39.14	33.32	25.18	25.12	19.18	5.90	D15P33E4GV00	D15P33E4GI00	D15P33E6GV00	D15P33E6GI00
25	53.03	47.04	39.12	38.84	33.12	5.70	D25P33E4GV00	D25P33E4GI00	D25P33E6GV00	D25P33E6GI00
37	69.32	63.50	55.68	55.30	49.68	5.70	D37P33E4GV00	D37P33E4GI00	D37P33E6GV00	D37P33E6GI00

Threaded ØT M3 = I  
Threaded ØT 4.40 = V

Threaded ØT M3 = I  
Threaded ØT 4.40 = V

LEAD FREE PART NUMBER										
SHELL	A±0.38	B±0.12	C±0.10	D±0.25	E±0.07	G±0.25	200 Mating cycles	500 Mating cycles		
09	30.81	24.99	16.96	16.79	10.96	5.90	D09P33E4GV00LF	D09P33E4GI00LF	D09P33E6GV00LF	D09P33E6GI00LF
15	39.14	33.32	25.18	25.12	19.18	5.90	D15P33E4GV00LF	D15P33E4GI00LF	D15P33E6GV00LF	D15P33E6GI00LF
25	53.03	47.04	39.12	38.84	33.12	5.70	D25P33E4GV00LF	D25P33E4GI00LF	D25P33E6GV00LF	D25P33E6GI00LF
37	69.32	63.50	55.68	55.30	49.68	5.70	D37P33E4GV00LF	D37P33E4GI00LF	D37P33E6GV00LF	D37P33E6GI00LF

Threaded ØT M3 = I  
Threaded ØT 4.40 = V

Threaded ØT M3 = I  
Threaded ØT 4.40 = V

GENERAL CHARACTERISTICS : SEE DRAWING C01-8646-0000

mat'l. code		surface ISO 1302		tolerance ISO 406 ISO 1101		projection		product family	
-		✓				MM		D-SUB	
ltr	ecn no	dr	date	tolerances unless otherwise specified		MM		title	
D	ELX-I-19243	AB	2014-10-29					MALE CONNECT. DELTA-D R/A SCREW LOCK, HARPOON & METAL PLATE	
				angles	linear	scale 2:1		dwg no	
				0°±2'	.00±0.1 .00±0.1 .000±0.1			sheet 1 of 1	
				dr	JOHN SLEEBA	1993-04-07		size	
				enr	ALIAS BABU	2014-10-29		A3	
				chr	MITHUN PAUL	2014-10-29		C01-8646-0825	
				app	BIJU K PAUL	2014-10-29		type Product Customer Drawing	
sheet index	revision sheet	D	1						