

**Precision Thick Film Chip Resistors**

**ERJ G : 01005, 0201**  
**ERJ R : 0201, 0402, 0603, 0805**  
**ERJ E : 0603, 0805, 1206,**  
**1210, 1812, 2010, 2512**



Type: **ERJ XG, 1G**  
**ERJ 1R, 2R, 3R, 6R**  
**ERJ 3E, 6E, 8E, 14, 12, 1T**

■ **Features**

- Small size and lightweight
- High reliability  
Metal glaze thick film resistive element and three layers of electrodes
- Compatible with placement machines  
Taping packaging available
- Suitable for both reflow and flow soldering
- RoHS compliant

- Low Resistance Tolerance  
ERJXG, 1G, 2R, 3E, 6E, 8E, 14, 12, 1T Series ..... ±1 %  
ERJ1R, 2R, 3R, 6R Series ..... ±0.5 %
- Reference Standards  
IEC 60115-8, JIS C 5201-8, EIAJ RC-2134B

■ **Packaging Methods, Land Pattern, Soldering Conditions and Safety Precautions**

Please see Data Files

■ **Explanation of Part Numbers**

- ERJ1R, 2R, 3R, 6R Series, ±0.5 % type

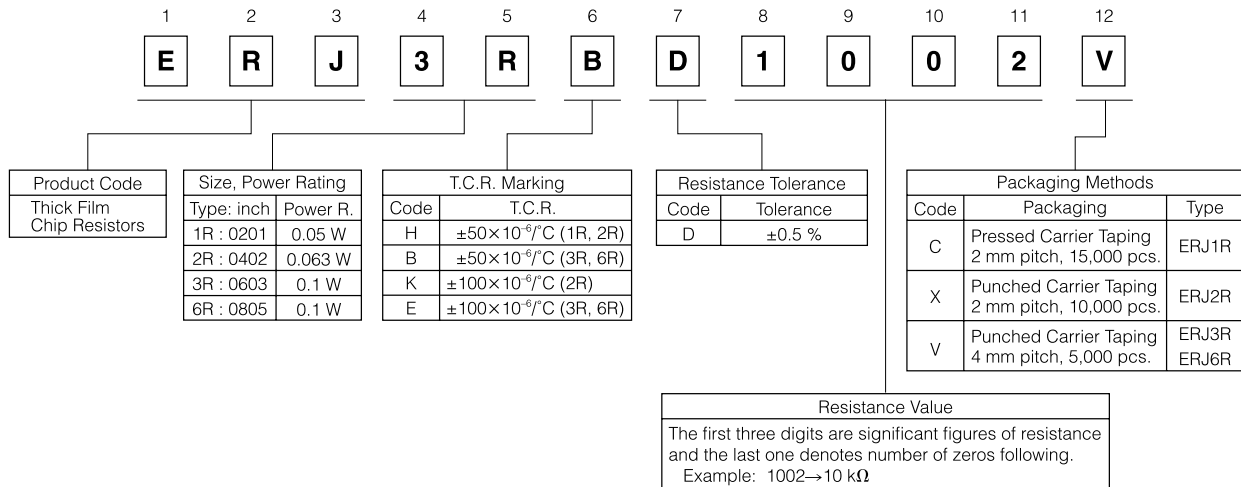

● ERJXG, 1G, 2R, 3E, 6E, 8E, 14, 12, 1T Series,  $\pm 1\%$  type

**ERJ-3EKF3010V**

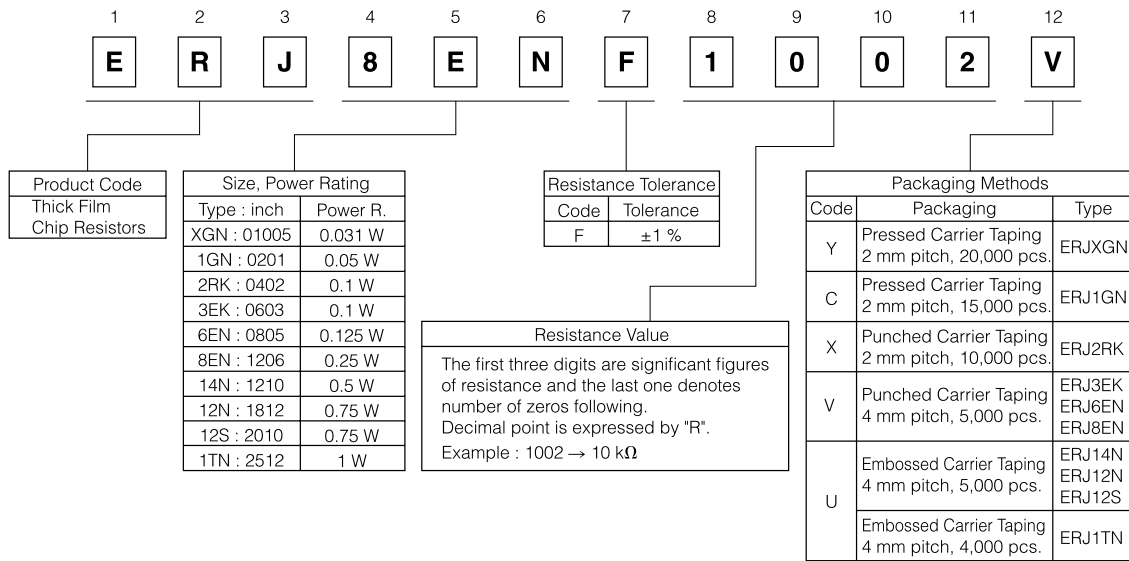

### Construction

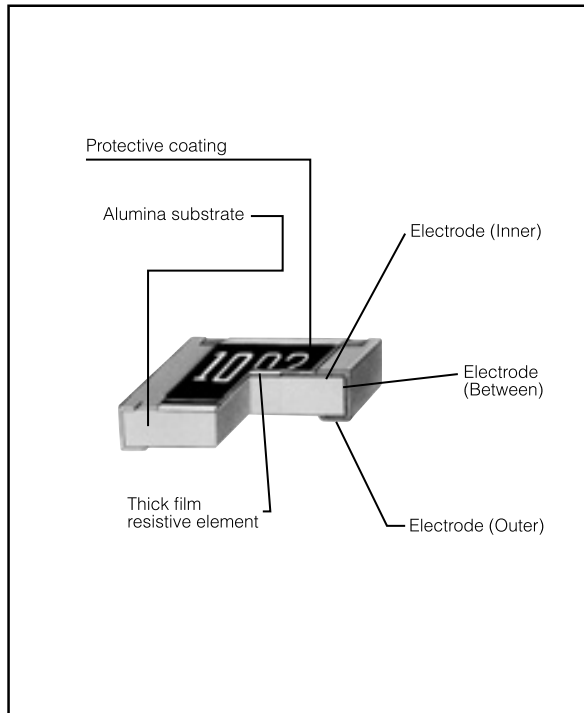

### Dimensions in mm (not to scale)

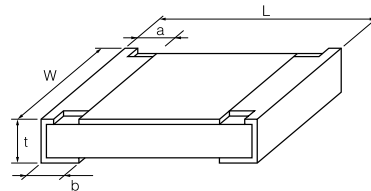

Type (inch size)	Dimensions (mm)					Mass (Weight) [g/1000 pcs.]
	L	W	a	b	t	
ERJXG (01005)	0.40 $^{+0.02}$	0.20 $^{+0.02}$	0.10 $^{+0.03}$	0.10 $^{+0.03}$	0.13 $^{+0.02}$	0.04
ERJ1G, 1R (0201)	0.60 $^{+0.03}$	0.30 $^{+0.03}$	0.10 $^{+0.05}$	0.15 $^{+0.05}$	0.23 $^{+0.03}$	0.15
ERJ2R□ (0402)	1.00 $^{+0.05}$	0.50 $^{+0.05}$	0.20 $^{+0.10}$	0.25 $^{+0.05}$	0.35 $^{+0.05}$	0.8
ERJ3R□ ERJ3EK (0603)	1.60 $^{+0.15}$	0.80 $^{+0.15}$ $^{-0.05}$	0.30 $^{+0.20}$	0.30 $^{+0.15}$	0.45 $^{+0.10}$	2
ERJ6R□ ERJ6EN (0805)	2.00 $^{+0.20}$	1.25 $^{+0.10}$	0.40 $^{+0.20}$	0.40 $^{+0.20}$	0.60 $^{+0.10}$	4
ERJ8EN (1206)	3.20 $^{+0.05}$ $^{-0.20}$	1.60 $^{+0.05}$ $^{-0.15}$	0.50 $^{+0.20}$	0.50 $^{+0.20}$	0.60 $^{+0.10}$	10
ERJ14N (1210)	3.20 $^{+0.20}$	2.50 $^{+0.20}$	0.50 $^{+0.20}$	0.50 $^{+0.20}$	0.60 $^{+0.10}$	16
ERJ12N (1812)	4.50 $^{+0.20}$	3.20 $^{+0.20}$	0.50 $^{+0.20}$	0.50 $^{+0.20}$	0.60 $^{+0.10}$	27
ERJ12S (2010)	5.00 $^{+0.20}$	2.50 $^{+0.20}$	0.60 $^{+0.20}$	0.60 $^{+0.20}$	0.60 $^{+0.10}$	27
ERJ1TN (2512)	6.40 $^{+0.20}$	3.20 $^{+0.20}$	0.65 $^{+0.20}$	0.60 $^{+0.20}$	0.60 $^{+0.10}$	45

### ■ Ratings <±0.5 %>

Type (inch size)	Power Rating at 70 °C (W)	Limiting Element Voltage <sup>(1)</sup> (V)	Maximum Overload Voltage <sup>(2)</sup> (V)	Resistance Tolerance (%)	Resistance Range (Ω)	T.C.R. (×10 <sup>-6</sup> /°C)	Category Temperature Range (°C)
ERJ1RH (0201)	0.05	15	30	±0.5	1 k to 1 M (E24, E96)	±50	-55 to +125
ERJ2RH (0402)	0.063	50	100	±0.5	100 to 100 k (E24, E96)	±50	-55 to +125
ERJ2RK (0402)	0.063	50	100	±0.5	10 to 97.6 102 k to 1 M (E24, E96)	±100	-55 to +125
ERJ3RB (0603)	0.1	50	100	±0.5	100 to 100 k (E24, E96)	±50	-55 to +125
ERJ3RE (0603)	0.1	50	100	±0.5	10 to 97.6 102 k to 1 M (E24, E96)	±100	-55 to +125
ERJ6RB (0805)	0.1	150	200	±0.5	100 to 100 k (E24, E96)	±50	-55 to +125
ERJ6RE (0805)	0.1	150	200	±0.5	10 to 97.6 102 k to 1 M (E24, E96)	±100	-55 to +125

### <±1 %>

Type (inch size)	Power Rating at 70 °C (W)	Limiting Element Voltage <sup>(1)</sup> (V)	Maximum Overload Voltage <sup>(2)</sup> (V)	Resistance Tolerance (%)	Resistance Range (Ω)	T.C.R. (×10 <sup>-6</sup> /°C)	Category Temperature Range (°C)
ERJXGN (01005)	0.031	15	30	±1	10 to 1 M (E24, E96)	<100 Ω : ±300 100 Ω ≤ : ±200	-55 to +125
ERJ1GN (0201)	0.05	25	50	±1	10 to 1 M <sup>(3)</sup> (E24, E96)	±200	-55 to +125
ERJ2RK (0402)	0.1	50	100	±1	10 to 1 M <sup>(3)</sup> (E24, E96)	±100	-55 to +155
ERJ3EK (0603)	0.1	75	150	±1	10 to 1 M (E24, E96)	±100	-55 to +155
ERJ6EN (0805)	0.125	150	200	±1	10 to 2.2 M (E24, E96)	±100	-55 to +155
ERJ8EN (1206)	0.25	200	400	±1	10 to 2.2 M (E24, E96)	±100	-55 to +155
ERJ14N (1210)	0.5	200	400	±1	10 to 1 M (E24, E96)	±100	-55 to +155
ERJ12N (1812)	0.75	200	500	±1	10 to 1 M (E24, E96)	±100	-55 to +155
ERJ12S (2010)	0.75	200	500	±1	10 to 1 M (E24, E96)	±100	-55 to +155
ERJ1TN (2512)	1	200	500	±1	10 to 1 M (E24, E96)	±100	-55 to +155

- (1) Rated Continuous Working Voltage (RCWV) shall be determined from  $RCWV = \sqrt{\text{Power Rating} \times \text{Resistance Values}}$ , or Limiting Element Voltage listed above, whichever less.
- (2) Overload (Short-time Overload) Test Voltage (SOTV) shall be determined from  $SOTV = 2.5$  (Only ERJ2RK ±1% = 2.0) × Power Rating or max. Overload Voltage listed above whichever less.
- (3) Please contact us when you need a type with a resistance of less than 10 Ω.

### Power Derating Curve

For resistors operated in ambient temperatures above 70 °C, power rating shall be derated in accordance with the figure on the right.

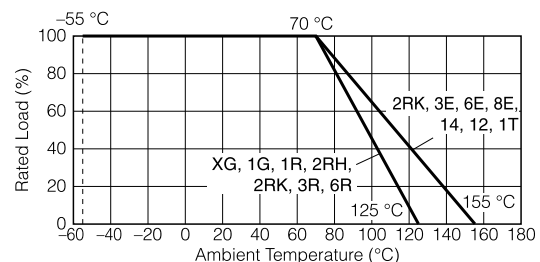

Design and specifications are each subject to change without notice. Ask factory for the current technical specifications before purchase and/or use. Should a safety concern arise regarding this product, please be sure to contact us immediately.

03 Aug. 2012