

THIS DRAWING IS UNPUBLISHED. RELEASED FOR PUBLICATION
 © COPYRIGHT - By - ALL RIGHTS RESERVED.

LOC	DIST	REVISIONS					
GP	00	P	LTR	DESCRIPTION	DATE	DWN	APVD
		D		REVISED PER ECO-11-020105	26OCT2011	CJV	CWR

25-06188

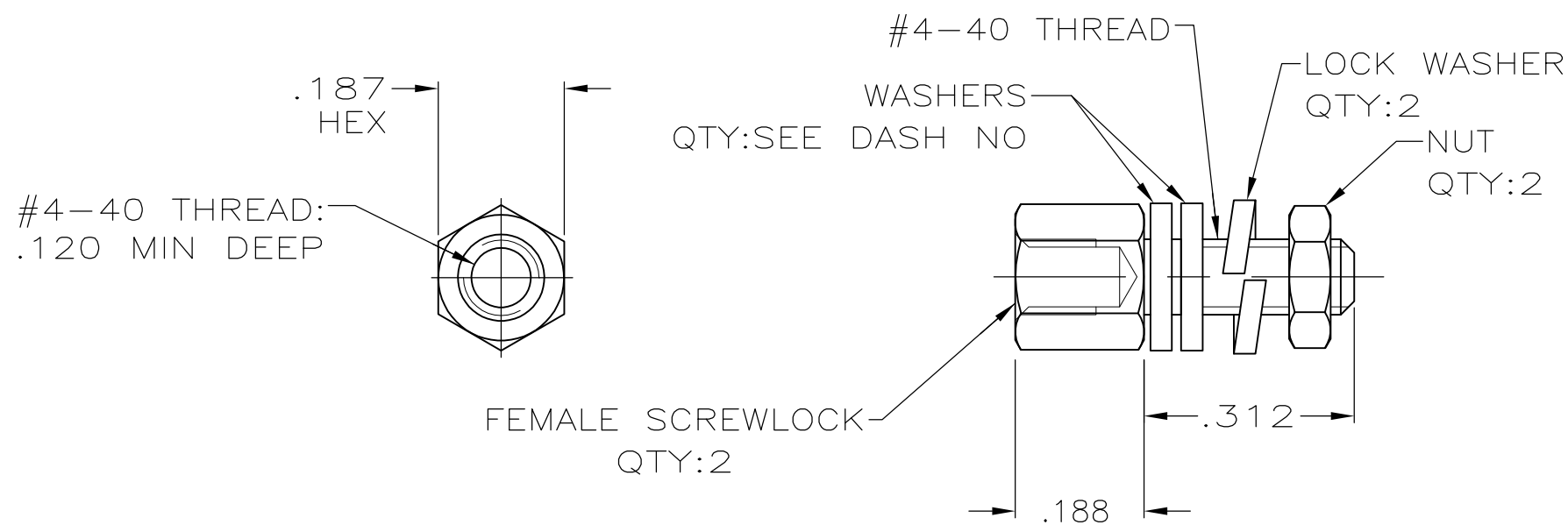

- 1 ZINC PLATED .000200-000400 THICK YELLOW CHROMATE COATING.
- 2 ZINC PLATED .000200-000400 THICK CLEAR CHROMATE COATING.
- 3. PARTS PACKAGED UNASSEMBLED.
- 4 PARTS PACKED AS A UNIT KIT.
- 5 PARTS INDIVIDUALLY BULK PACKED & SHIPPED AS A UNIT PACKAGE.
- 6. IDENTIFIED BY MIL SPEC PART NUMBER M24308/26-1 FOR -8 ONLY & TYCO PART NUMBER (FOR ALL DASH NUMBERS).
- 7 CHROMATE FINISH PER ASTM B633 EXCEPT FOR USE OF TRIVALENT CHROMIUM TO MEET RoHS REGULATIONS.

OBSOLETE	4	6	1	5205817-9
	4	6	1/7	5205817-8
	5	4	2	5205817-4
	4	4	2	5205817-3
	5	4	1	5205817-2
	4	4	1	5205817-1
	PACKAGING	NO OF WASHERS	FINISH	PART NUMBER

THIS DRAWING IS A CONTROLLED DOCUMENT.		DWN	S.WAITMAN	27JUN05	STE TE Connectivity		
DIMENSIONS: INCHES		CHK	C.ROHDE	27JUN05			
TOLERANCES UNLESS OTHERWISE SPECIFIED:		APVD	M.WALMSLEY	27JUN05	NAME		
0 PLC ± -		PRODUCT SPEC		KIT, SCREWLOCK, FEMALE, AMPLIMITE			
1 PLC ± -		APPLICATION SPEC		-			
2 PLC ± -		SIZE	A3	CAGE CODE	00779	DRAWING NO	C-5205817
3 PLC ± .005		WEIGHT		RESTRICTED TO		-	
4 PLC ± -		CUSTOMER DRAWING					
ANGLES ± -		SCALE		4:1		SHEET 1 OF 1	
FINISH		SEE TABLE		REV		D	