

DATE	DESCRIPTION	REV.
9.17.04	CHANGE AS PER ECN 04-104	F
8.15.11	ECN 11-106; ADD FLATNESS	G

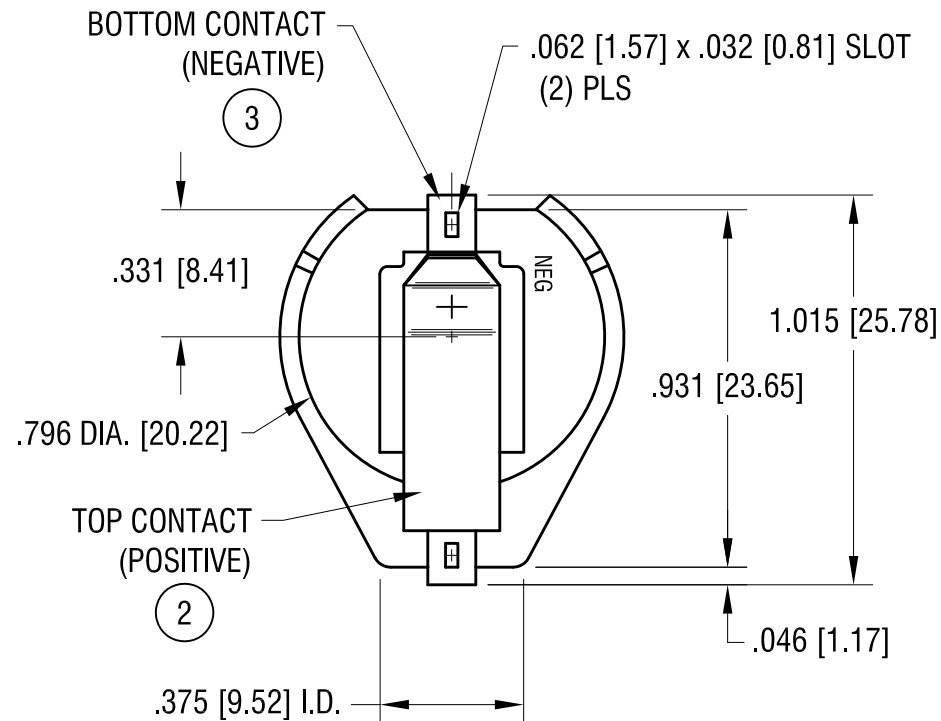

THIS DOCUMENT IS THE PROPERTY OF KEYSTONE ELECTRONICS CORP. AND SHALL NOT BE REPRODUCED, DISTRIBUTED OR USED AS A BASIS FOR MANUFACTURE WITHOUT PRIOR WRITTEN PERMISSION FROM KEYSTONE ELECTRONICS CORP.

MOUNTING DETAIL

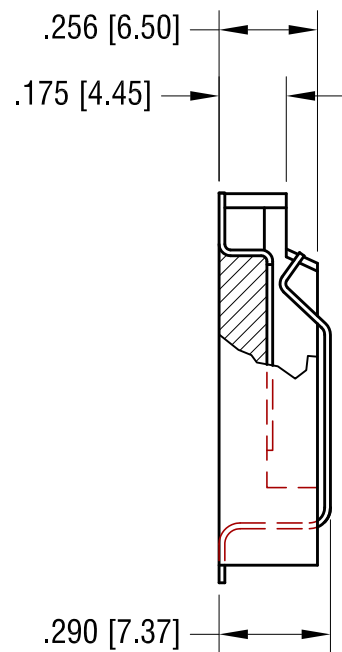
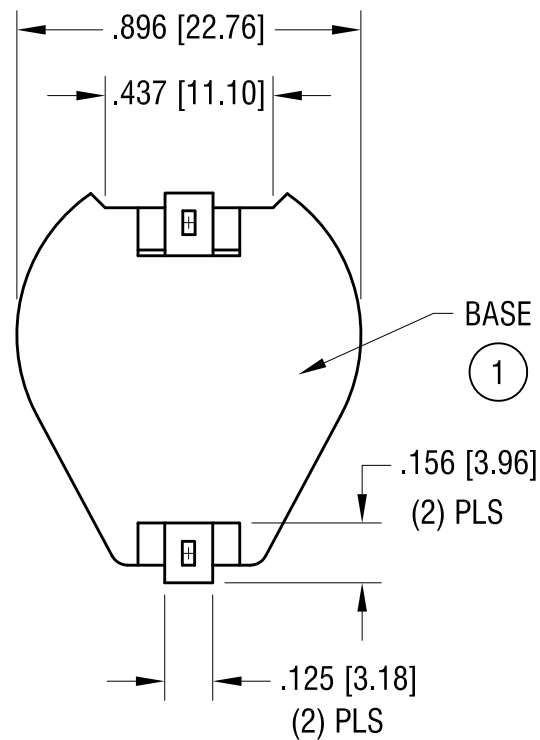
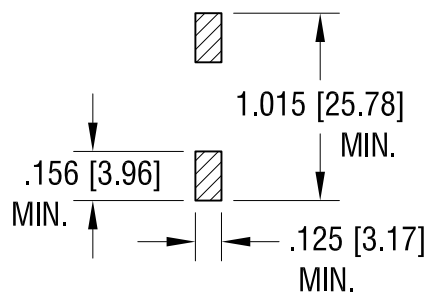

25-06098

ITEM	DESCRIPTION	MATERIAL/FINISH
1	BASE BLACK	HIGH TEMPERATURE NYLON (UL 94V-0)
2	TOP CONTACT	SPRING STEEL .015 [0.38] TH'K
3	BOTTOM CONTACT	TIN NICKEL PLATE

KEYSTONE ELECTRONICS CORP.			
www.keyelco.com • ASTORIA, N.Y. 11105-2017 • Tel (718) 956-8900			
PART NAME 20mm BATTERY HOLDER, SMT			
MATERIAL AS NOTED			
FINISH AS NOTED		DRN BY BOONE	DATE 12.14.92
		APPD LN	SCALE 2X
TOLERANCES DECIMAL ANGULAR UNLESS OTHERWISE SPECIFIED	INCH [MM] ± .010 [± 0.25] ± 1°	CODE C	DWG NO. 1061