

25-05869

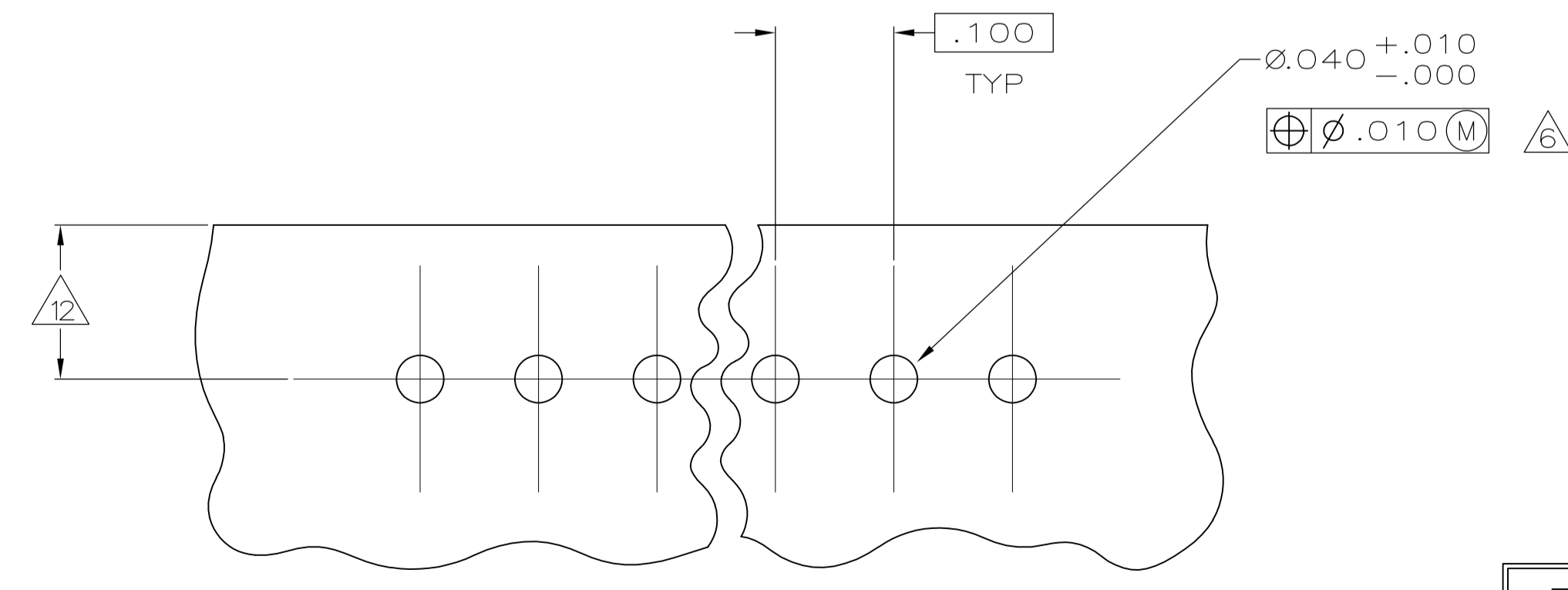
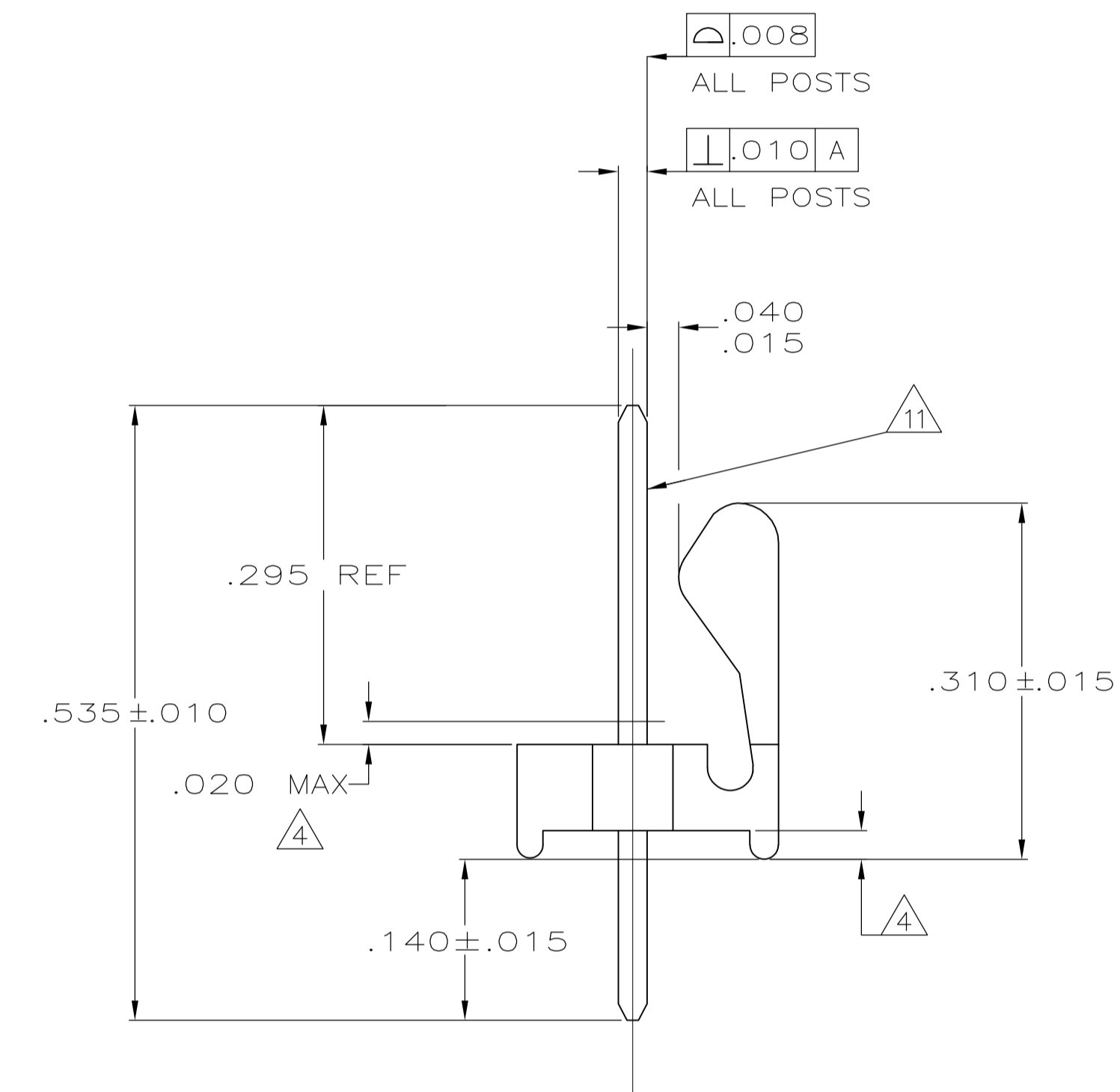
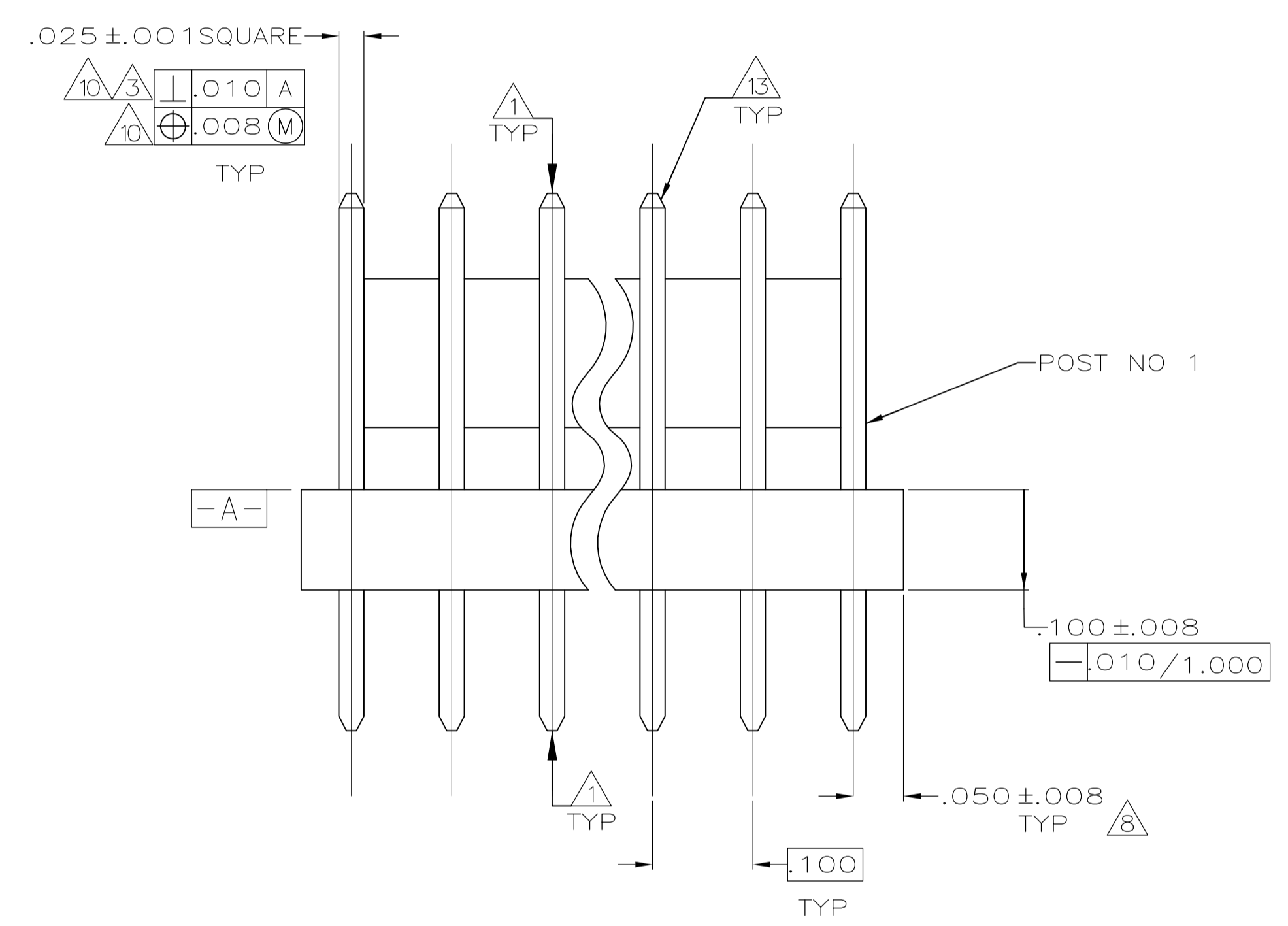
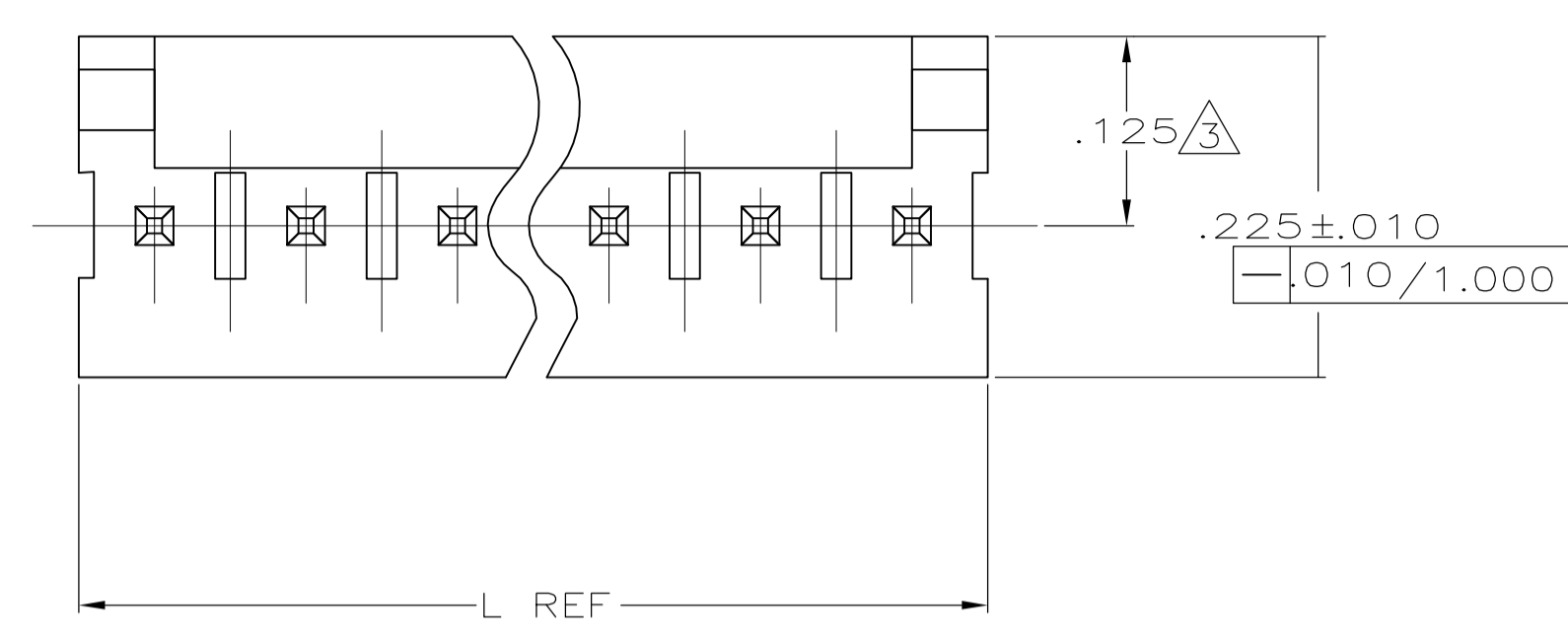

IN	MM	IN	MM
.035	0.89	.535	13.59
.032	0.81	.310	7.87
.025	0.64	.295	7.49
.020	0.51	.225	5.72
.015	0.38	.140	3.56
.010	0.25	.130	3.30
.008	0.20	.125	3.18
.005	0.13	.100	2.54
.003	0.08	.063	1.60
.001	0.03	.050	1.27
.000	0.00	.040	1.02
IN	MM	IN	MM

CONVERSION TABLE

1. POST TO WITHSTAND 13 NEWTONS (3 LBS) MIN. AXIAL FORCE IN BOTH DIRECTIONS SHOWN WITHOUT DISLODGING.
2. TOLERANCES APPLY TO SOLDER SIDE OF BOARD.
3. MEASURED AT SURFACE $-A-$
4. PLASTIC FLASH PERMITTED IN THIS AREA.
5. PARTS COMPLY WITH AMP SOLDERABILITY SPEC. NO. 109-11-2.
6. ONE HOLE MAY BE UNDERSIZED (.032-.035 DIA) FOR ASSEMBLY RETENTION DURING WAVE SOLDERING.
7. MATERIAL: HEADER-THERMOPLASTIC POLYESTER
UL94V-0(NATURAL)
POST-COPPER ALLOY (TIN-PLATED)
8. COORDINATE DIMENSION APPLIES FROM CENTER OF ACTUAL FEATURE.
9. PLASTIC BURRS CAUSED BY CUT-OFF TOOLING ARE PERMITTED WITHIN THE MAXIMUM TOLERANCE ENVELOPE.
10. POSTS TO BE MEASURED WHEN STRIP IS HELD FLAT.
11. POSTS MUST WITHSTAND TWO 90° BENDS AGAINST EXTRUSION WITHOUT BREAKING.
12. DIMENSION SHOULD BE .130 MIN WHEN MATING WITH A MTA 100 CONNECTOR ASSEMBLY OR A CST 100 CONNECTOR.
13. PIN BURR OF .005 MAX. VERTICAL AND .003 MAX. HORIZONTAL PERMITTED AT POST TIPS ON BOTH ENDS.

L	MM	NO OF POSITIONS	PART NUMBER
2.800	71.12	28	2-640456-8
2.700	68.58	27	2-640456-7
2.600	66.04	26	2-640456-6
2.500	63.50	25	2-640456-5
2.400	60.96	24	2-640456-4
2.300	58.42	23	2-640456-3
2.200	55.88	22	2-640456-2
2.100	53.34	21	2-640456-1
2.000	50.80	20	2-640456-0
1.900	48.26	19	1-640456-9
1.800	45.72	18	1-640456-8
1.700	43.18	17	1-640456-7
1.600	40.64	16	1-640456-6
1.500	38.10	15	1-640456-5
1.400	35.56	14	1-640456-4
1.300	33.02	13	1-640456-3
1.200	30.48	12	1-640456-2
1.100	27.94	11	1-640456-1
1.000	25.40	10	1-640456-0
.900	22.86	9	640456-9
.800	20.32	8	640456-8
.700	17.78	7	640456-7
.600	15.24	6	640456-6
.500	12.70	5	640456-5
.400	10.16	4	640456-4
.300	7.62	3	640456-3
.200	5.08	2	640456-2
IN	MM	NO OF POSITIONS	PART NUMBER

METRIC

THIS DRAWING IS A CONTROLLED DOCUMENT.

DIMENSIONS: INCHES	TOLERANCES UNLESS OTHERWISE SPECIFIED:	DIN K. WHITAKER 11JUN2004	TE Connectivity
0. PLC ± -	1. PLC ± -	CHK D. ROSSI 11JUN04	NAME MTA-100 HEADER ASSEMBLY, POLARIZED, NOTCHED, .025 SQUARE STRAIGHT POST, TIN PLATED
2. PLC ± -	3. PLC ± .005	APVD D. ROSSI 11JUN04	APPLICATION SPEC
4. PLC ± -	ANGLES ± # 0°30'	SIZE A1	CAGE CODE 00779
MATERIAL	FINISH	WEIGHT	DRAWING NO. 640456
		CUSTOMER DRAWING	SCALE 8:1 SHEET 1 OF 1 REV W1