

4

3

2

1

THIS DRAWING IS UNPUBLISHED. RELEASED FOR PUBLICATION AUG 2006  
COPYRIGHT BY TYCO ELECTRONICS CORPORATION. ALL RIGHTS RESERVED.

LOC	DIST	REVISIONS			
P	LTR	DESCRIPTION	DATE	DWN	APVD
DW	-	A4	REVISED (ECR-10-020637)	07OCT10	JL WK

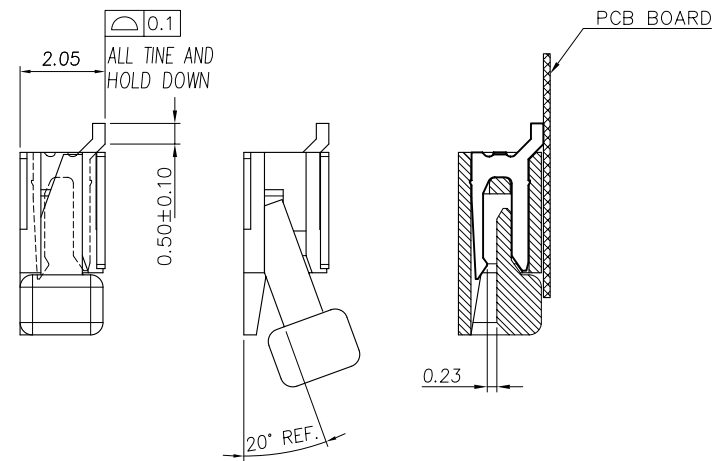
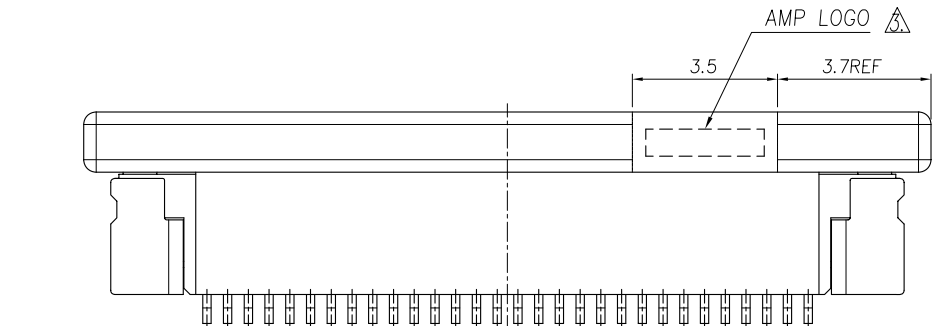
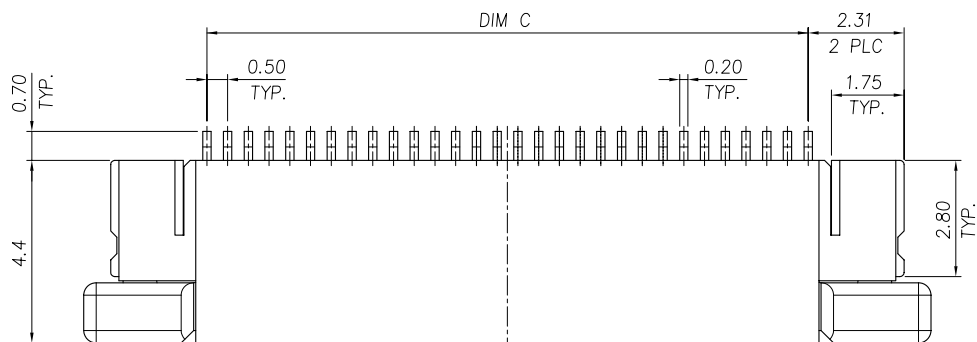

24.50	25.60	30.43	50	5-1734839-0
24.00	25.10	29.93	49	4-1734839-9
23.50	24.60	29.43	48	4-1734839-8
23.00	24.10	28.93	47	4-1734839-7
22.50	23.60	28.43	46	4-1734839-6
22.00	23.10	27.93	45	4-1734839-5
21.50	22.60	27.43	44	4-1734839-4
21.00	22.10	26.93	43	4-1734839-3
20.50	21.60	26.43	42	4-1734839-2
20.00	21.10	25.93	41	4-1734839-1
19.50	20.60	25.43	40	4-1734839-0
19.00	20.10	24.93	39	3-1734839-9
18.50	19.60	24.43	38	3-1734839-8
18.00	19.10	23.93	37	3-1734839-7
17.50	18.60	23.43	36	3-1734839-6
17.00	18.10	22.93	35	3-1734839-5
16.50	17.60	22.43	34	3-1734839-4
16.00	17.10	21.93	33	3-1734839-3
15.50	16.60	21.43	32	3-1734839-2
15.00	16.10	20.93	31	3-1734839-1
14.50	15.60	20.43	30	3-1734839-0
14.00	15.10	19.93	29	2-1734839-9
13.50	14.60	19.43	28	2-1734839-8
13.00	14.10	18.93	27	2-1734839-7
12.50	13.60	18.43	26	2-1734839-6
12.00	13.10	17.93	25	2-1734839-5
11.50	12.60	17.43	24	2-1734839-4
11.00	12.10	16.93	23	2-1734839-3
10.50	11.60	16.43	22	2-1734839-2
10.00	11.10	15.93	21	2-1734839-1
9.50	10.60	15.43	20	2-1734839-0
9.00	10.10	14.93	19	1-1734839-9
8.50	9.60	14.43	18	1-1734839-8
8.00	9.10	13.93	17	1-1734839-7
7.50	8.60	13.43	16	1-1734839-6
7.00	8.10	12.93	15	1-1734839-5
6.50	7.60	12.43	14	1-1734839-4
6.00	7.10	11.93	13	1-1734839-3
5.50	6.60	11.43	12	1-1734839-2
5.00	6.10	10.93	11	1-1734839-1
4.50	5.60	10.43	10	1-1734839-0
4.00	5.10	9.93	09	0-1734839-9
3.50	4.60	9.43	08	0-1734839-8
3.00	4.10	8.93	07	0-1734839-7
2.50	3.60	8.43	06	0-1734839-6
2.00	3.10	7.93	05	0-1734839-5
C	B	A	POS.	PART NUMBER
DIMENSIONS				

NOTE:  
 1. MATERIAL:  
 HOUSING: HIGH TEMP. THERMOPLASTIC, UL 94V-0, COLOR: NATURE.  
 ACTUATOR: THERMOPLASTIC, UL 94 V-0, COLOR: IVORY.  
 HOLD DOWN: PHOSPHOR BRONZE.  
 CONTACT: PHOSPHOR BRONZE.  
 2. FINISH:  
 CONTACT: GOLD FLASH OVER ALL 50" MIN. NICKEL UNDERPLATED.  
 HOLD DOWN: 100u" MIN. TIN PLATING ON SOLDER AREA, 50u" MIN. NICKEL UNDERPLATED ALL OVER.  
 WITHOUT AMP LOGO FOR 12 POSITION UNDER.

# 25-05683

THIS DRAWING IS A CONTROLLED DOCUMENT.		DWN J. LAI 15APR2009	Tyco Electronics Corporation Taipei, Taiwan	
DIMENSIONS: MM		CHK S. CHIEN 15APR2009	NAME	
TOLERANCES UNLESS OTHERWISE SPECIFIED:		APVD W. KODAMA 15APR2009	FPC CONNECTOR, 0.5mm PITCH, TOP CONTACT, SMT TYPE.	
0 PLC ± 0.1		PRODUCT SPEC 108-57523	QUALIFICATION TEST REPORT 501-57598	
1 PLC ± 0.1		WEIGHT - GRAMS	SIZE A3	CAGE CODE 00779
2 PLC ± 0.1		CUSTOMER DRAWING	DRAWING NO C=1734839	RESTRICTED TO -
3 PLC ± 0.1			SCALE -	SHEET 1 of 3
4 PLC ± -				REV A4
ANGLES ± 1°				
MATERIAL SEE NOTE				
FINISH SEE NOTE				

LOC	DIST	REVISIONS			
P	LTR	DESCRIPTION	DATE	DWN	APVD
DW		SEE SHEET 1.			

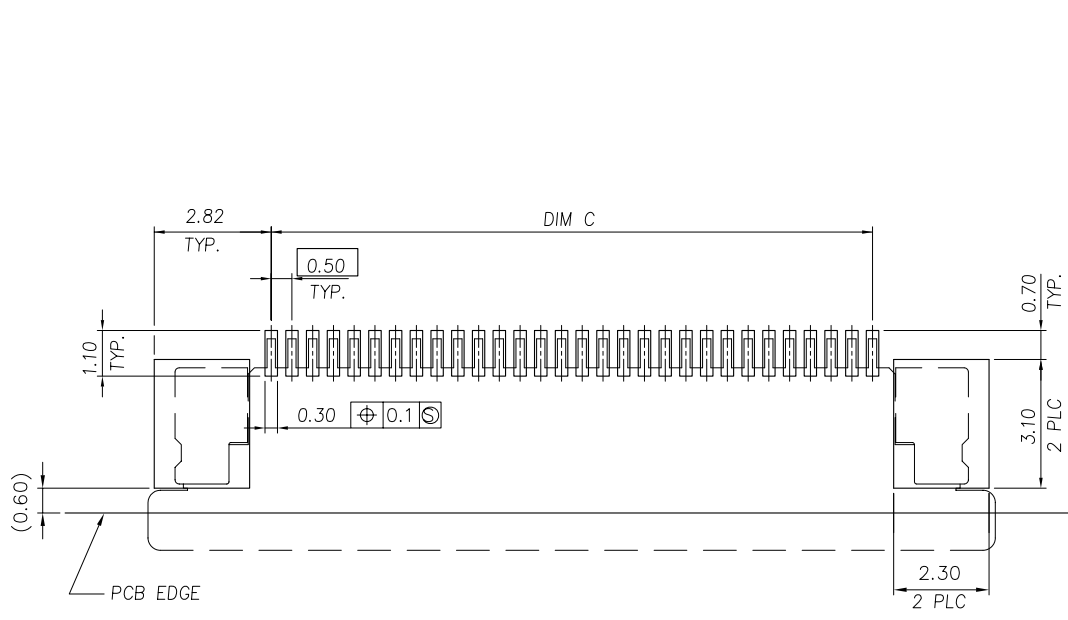

RECOMMENDED PCB DIMENSIONS DIAGRAM  
 TOLERANCE: ±0.05

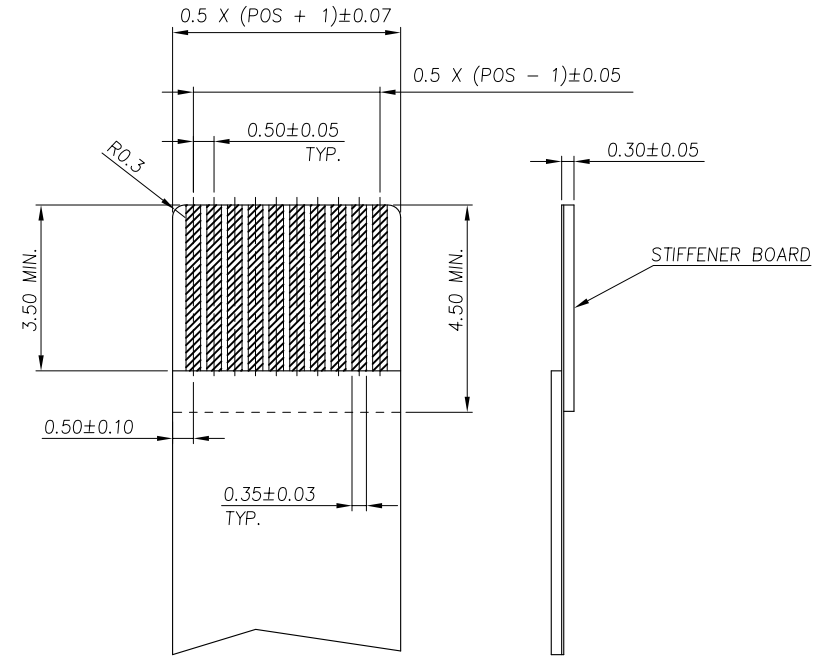

RECOMMENDED FPC DIMENSIONS DIAGRAM

THIS DRAWING IS A CONTROLLED DOCUMENT.		DWN	Tyco Electronics Corporation	
		CHK	Taipei, Taiwan	
DIMENSIONS: MM		APVD	NAME	
TOLERANCES UNLESS OTHERWISE SPECIFIED:		PRODUCT SPEC	FPC CONNECTOR, 0.5mm PITCH, TOP CONTACT, SMT TYPE.	
0 PLC ± -		APPLICATION SPEC	SIZE	RESTRICTED TO
1 PLC ± -			A3	
2 PLC ± -		WEIGHT	CAGE CODE	
3 PLC ± -			00779	
4 PLC ± -			DRAWING NO	
ANGLES ± -			G=1734839	
MATERIAL	FINISH	CUSTOMER DRAWING		SCALE
				SHEET
				2 of 3
				REV A4

LOC		DIST		REVISIONS				
P	LTR	DESCRIPTION	DATE	DWN	APVD			
		SEE SHEET 1.						

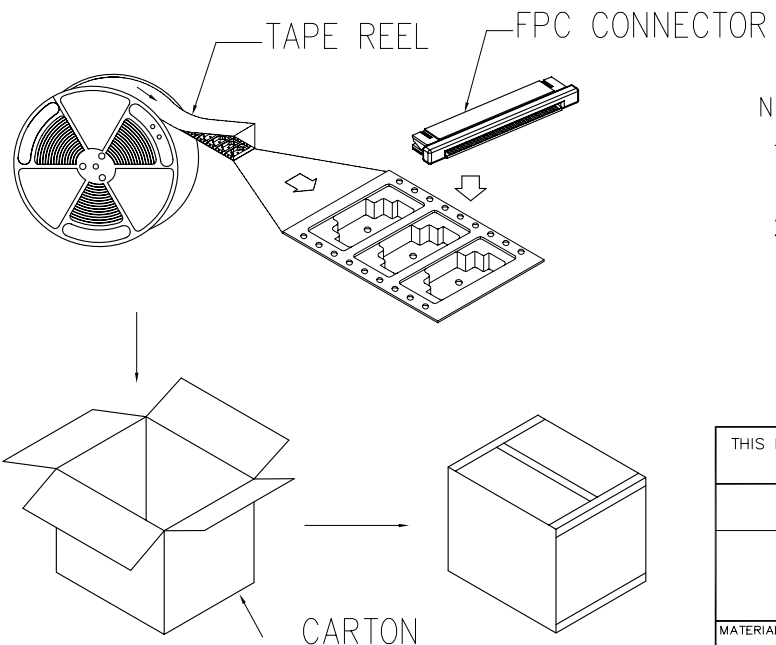
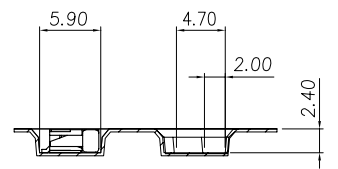
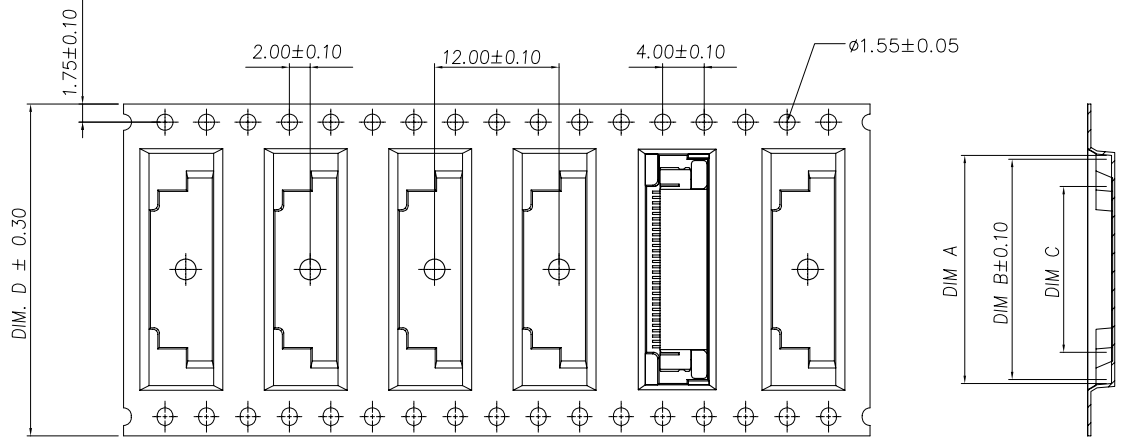

- NOTE :
- 1. TAPE REEL:  
DIAMETER: 13", THICKNESS : 0.35±0.05mm.
  - 2. CARTON:  
SIZE: 350mm(L)X 350mm(W)X 340mm(H).
  - 3. WEIGHT:  
NET WEIGHT: 7.5kg  
GROSS WEIGHT: 13.4kg

QTY	QTY	QTY	QTY	QTY	QTY	QTY	QTY
44.00	25.50	30.75	31.50	50	5-1734839-0		
44.00	25.00	30.25	31.00	49	4-1734839-9		
44.00	24.50	29.75	30.50	48	4-1734839-8		
44.00	24.00	29.25	30.00	47	4-1734839-7		
44.00	23.50	28.75	29.50	46	4-1734839-6		
44.00	23.00	28.25	29.00	45	4-1734839-5		
44.00	22.50	27.75	28.50	44	4-1734839-4		
44.00	22.00	27.25	28.00	43	4-1734839-3		
44.00	21.50	26.75	27.50	42	4-1734839-2		
44.00	21.00	26.25	27.00	41	4-1734839-1		
44.00	20.50	25.75	26.50	40	4-1734839-0		
44.00	20.00	25.25	26.00	39	3-1734839-9		
44.00	19.50	24.75	25.50	38	3-1734839-8		
44.00	19.00	24.25	25.00	37	3-1734839-7		
44.00	18.50	23.75	24.50	36	3-1734839-6		
44.00	18.00	23.25	24.00	35	3-1734839-5		
44.00	17.50	22.75	23.50	34	3-1734839-4		
44.00	17.00	22.25	23.00	33	3-1734839-3		
44.00	16.50	21.75	22.50	32	3-1734839-2		
32.00	16.00	21.25	22.00	31	3-1734839-1		
32.00	15.50	20.75	21.50	30	3-1734839-0		
32.00	15.00	20.25	21.00	29	2-1734839-9		
32.00	14.50	19.75	20.50	28	2-1734839-8		
32.00	14.00	19.25	20.00	27	2-1734839-7		
32.00	13.50	18.75	19.50	26	2-1734839-6		
32.00	13.00	18.25	19.00	25	2-1734839-5		
32.00	12.50	17.75	18.50	24	2-1734839-4		
32.00	12.00	17.25	18.00	23	2-1734839-3		
32.00	11.50	16.75	17.50	22	2-1734839-2		
24.00	11.00	16.25	17.00	21	2-1734839-1		
24.00	10.50	15.75	16.50	20	2-1734839-0		
24.00	10.00	15.25	16.00	19	1-1734839-9		
24.00	9.50	14.75	15.50	18	1-1734839-8		
24.00	9.00	14.25	15.00	17	1-1734839-7		
24.00	8.50	13.75	14.50	16	1-1734839-6		
24.00	8.00	13.25	14.00	15	1-1734839-5		
24.00	7.50	12.75	13.50	14	1-1734839-4		
24.00	7.00	12.25	13.00	13	1-1734839-3		
24.00	6.50	11.75	12.50	12	1-1734839-2		
24.00	6.00	11.25	12.00	11	1-1734839-1		
24.00	5.50	10.75	11.50	10	1-1734839-0		
24.00	5.00	10.25	11.00	09	0-1734839-9		
24.00	4.50	9.75	10.50	08	0-1734839-8		
24.00	4.00	9.25	10.00	07	0-1734839-7		
24.00	3.50	8.75	9.50	06	0-1734839-6		
16.00	3.00	8.25	9.00	05	0-1734839-5		

DIMENSIONS: MM		TOLERANCES UNLESS OTHERWISE SPECIFIED:		DWN		Tyco Electronics		Tyco Electronics Corporation	
0 PLC	±	0 PLC	±	CHK	/	NAME		Taipei, Taiwan	
1 PLC	±	1 PLC	±	APVD	/	PRODUCT SPEC		FPC CONNECTOR, 0.5mm PITCH,	
2 PLC	±	2 PLC	±	PRODUCT SPEC	/	APPLICATION SPEC		TOP CONTACT, SMT TYPE.	
3 PLC	±	3 PLC	±	APPLICATION SPEC	/	SIZE	CAGE CODE	DRAWING NO	RESTRICTED TO
4 PLC	±	4 PLC	±	WEIGHT	-	A3	00779	C=1734839	/
ANGLES	±	ANGLES	±	CUSTOMER DRAWING	/	SCALE		SHEET 3 of 3	
MATERIAL	/	FINISH	/	CUSTOMER DRAWING		SCALE		REV A4	