

- Low Supply Voltage Range: 1.8 V to 3.6 V
- Ultralow Power Consumption
  - Active Mode: 270  $\mu$ A at 1 MHz, 2.2 V
  - Standby Mode: 0.7  $\mu$ A
  - Off Mode (RAM Retention): 0.1  $\mu$ A
- Ultrafast Wake-Up From Standby Mode in Less Than 1  $\mu$ s
- 16-Bit RISC Architecture, 62.5-ns Instruction Cycle Time
- Basic Clock Module Configurations:
  - Internal Frequencies up to 16 MHz With Four Calibrated Frequencies to  $\pm$ 1%
  - Internal Very-Low-Power Low-Frequency Oscillator
  - 32-kHz Crystal
  - High-Frequency Crystal up to 16 MHz
  - Resonator
  - External Digital Clock Source
  - External Resistor
- 16-Bit Timer\_A With Three Capture/Compare Registers
- 16-Bit Timer\_B With Three Capture/Compare Registers
- Universal Serial Communication Interface
  - Enhanced UART Supporting Auto-Baudrate Detection (LIN)
  - IrDA Encoder and Decoder
  - Synchronous SPI
  - I<sup>2</sup>C™
- 10-Bit 200-ksps Analog-to-Digital (A/D) Converter With Internal Reference, Sample-and-Hold, Autoscan, and Data Transfer Controller
- Two Configurable Operational Amplifiers (MSP430x22x4 Only)
- Brownout Detector
- Serial Onboard Programming, No External Programming Voltage Needed
- Programmable Code Protection by Security Fuse
- Bootstrap Loader
- On Chip Emulation Module
- Family Members Include:
  - MSP430F2232: 8KB + 256B Flash Memory 512B RAM
  - MSP430F2252: 16KB + 256B Flash Memory 512B RAM
  - MSP430F2272: 32KB + 256B Flash Memory 1KB RAM
  - MSP430F2234: 8KB + 256B Flash Memory 512B RAM
  - MSP430F2254: 16KB + 256B Flash Memory 512B RAM
  - MSP430F2274: 32KB + 256B Flash Memory 1KB RAM
- Available in a 38-Pin Thin Shrink Small-Outline Package (TSSOP) (DA) and 40-Pin QFN Package (RHA) (See Available Options)
- For Complete Module Descriptions, See the *MSP430x2xx Family User's Guide*, Literature Number SLAU144

## description

The Texas Instruments MSP430 family of ultralow-power microcontrollers consist of several devices featuring different sets of peripherals targeted for various applications. The architecture, combined with five low-power modes is optimized to achieve extended battery life in portable measurement applications. The device features a powerful 16-bit RISC CPU, 16-bit registers, and constant generators that contribute to maximum code efficiency. The digitally controlled oscillator (DCO) allows wake-up from low-power modes to active mode in less than 1  $\mu$ s.



This integrated circuit can be damaged by ESD. Texas Instruments recommends that all integrated circuits be handled with appropriate precautions. Failure to observe proper handling and installation procedures can cause damage. ESD damage can range from subtle performance degradation to complete device failure. Precision integrated circuits may be more susceptible to damage because very small parametric changes could cause the device not to meet its published specifications. These devices have limited built-in ESD protection.



Please be aware that an important notice concerning availability, standard warranty, and use in critical applications of Texas Instruments semiconductor products and disclaimers thereto appears at the end of this data sheet.

All trademarks are the property of their respective owners.

PRODUCTION DATA information is current as of publication date. Products conform to specifications per the terms of Texas Instruments standard warranty. Production processing does not necessarily include testing of all parameters.



POST OFFICE BOX 655303 • DALLAS, TEXAS 75265

Copyright © 2010 Texas Instruments Incorporated

# MSP430x22x2, MSP430x22x4 MIXED SIGNAL MICROCONTROLLER

SLAS504D - JULY 2006 - REVISED MARCH 2010

## description (continued)

The MSP430x22xx series is an ultralow-power mixed signal microcontroller with two built-in 16-bit timers, a universal serial communication interface, 10-bit A/D converter with integrated reference and data transfer controller (DTC), two general-purpose operational amplifiers in the MSP430x22x4 devices, and 32 I/O pins.

Typical applications include sensor systems that capture analog signals, convert them to digital values, and then process the data for display or for transmission to a host system. Stand-alone radio-frequency (RF) sensor front ends are another area of application.

### AVAILABLE OPTIONS<sup>†</sup>

T <sub>A</sub>	PACKAGED DEVICES <sup>‡</sup>	
	PLASTIC 38-PIN TSSOP (DA)	PLASTIC 40-PIN QFN (RHA)
-40°C to 85°C	MSP430F2232IDA MSP430F2252IDA MSP430F2272IDA MSP430F2234IDA MSP430F2254IDA MSP430F2274IDA	MSP430F2232IRHA MSP430F2252IRHA MSP430F2272IRHA MSP430F2234IRHA MSP430F2254IRHA MSP430F2274IRHA
-40°C to 105°C	MSP430F2232TDA <sup>§</sup> MSP430F2252TDA <sup>§</sup> MSP430F2272TDA <sup>§</sup> MSP430F2234TDA MSP430F2254TDA MSP430F2274TDA	MSP430F2232TRHA <sup>§</sup> MSP430F2252TRHA <sup>§</sup> MSP430F2272TRHA <sup>§</sup> MSP430F2234TRHA MSP430F2254TRHA MSP430F2274TRHA

<sup>†</sup> For the most current package and ordering information, see the Package Option Addendum at the end of this document, or see the TI web site at [www.ti.com](http://www.ti.com).

<sup>‡</sup> Package drawings, thermal data, and symbolization are available at [www.ti.com/packaging](http://www.ti.com/packaging).

<sup>§</sup> Product Preview

## DEVELOPMENT TOOL SUPPORT

All MSP430 microcontrollers include an Embedded Emulation Module (EEM) allowing advanced debugging and programming through easy to use development tools. Recommended hardware options include the following:

- Debugging and Programming Interface
  - MSP-FET430UIF (USB)
  - MSP-FET430PIF (Parallel Port)
- Debugging and Programming Interface with Target Board
  - MSP-FET430U38 (DA package)
- Production Programmer
  - MSP-GANG430



# MSP430x22x2, MSP430x22x4 MIXED SIGNAL MICROCONTROLLER

SLAS504D - JULY 2006 - REVISED MARCH 2010

## MSP430x22x2 device pinout, DA package

TEST/SBWTCK	1	38	P1.7/TA 2/TDO/TDI
DVCC	2	37	P1.6/TA 1/TDI
P2.5/Rosc	3	36	P1.5/TA 0/TMS
DVSS	4	35	P1.4/SMCLK/TCK
XOUT/P2.7	5	34	P1.3/TA 2
XIN/P2.6	6	33	P1.2/TA 1
$\overline{\text{RST}}$ /NMI/SBWDIO	7	32	P1.1/TA 0
P2.0/ACLK/A0	8	31	P1.0/TACLK/ADC 10CLK
P2.1/TAINCLK/SMCLK/A1	9	30	P2.4/TA 2/A4/VREF+/VeREF+
P2.2/TA 0/A2	10	29	P2.3/TA 1/A3/VREF-/VeREF-
P3.0/UCB 0STE/UCA 0CLK/A5	11	28	P3.7/A7
P3.1/UCB 0SIMO/UCB 0SDA	12	27	P3.6/A6
P3.2/UCB 0SOMI/UCB 0SCL	13	26	P3.5/UCA 0RXD/UCA0SOMI
P3.3/UCB 0CLK/UCA 0STE	14	25	P3.4/UCA 0TXD/UCA0SIMO
AVSS	15	24	P4.7/TBCLK
AVCC	16	23	P4.6/TBOUTH/A15
P4.0/TB0	17	22	P4.5/TB2/A14
P4.1/TB1	18	21	P4.4/TB1/A13
P4.2/TB2	19	20	P4.3/TB0/A12

## MSP430x22x4 device pinout, DA package

TEST/SBWTCK	1	38	P1.7/TA 2/TDO/TDI
DVCC	2	37	P1.6/TA 1/TDI
P2.5/Rosc	3	36	P1.5/TA 0/TMS
DVSS	4	35	P1.4/SMCLK/TCK
XOUT/P2.7	5	34	P1.3/TA 2
XIN/P2.6	6	33	P1.2/TA 1
$\overline{\text{RST}}$ /NMI/SBWDIO	7	32	P1.1/TA 0
P2.0/ACLK/A0/OA0I0	8	31	P1.0/TACLK/ADC 10CLK
P2.1/TAINCLK/SMCLK/A1/OA0O	9	30	P2.4/TA 2/A4/VREF+/VeREF+/OA1I0
P2.2/TA 0/A2/OA0I1	10	29	P2.3/TA 1/A3/VREF-/VeREF-/OA1I1/OA1O
P3.0/UCB 0STE/UCA 0CLK/A5	11	28	P3.7/A7/OA1I2
P3.1/UCB 0SIMO/UCB 0SDA	12	27	P3.6/A6/OA0I2
P3.2/UCB 0SOMI/UCB 0SCL	13	26	P3.5/UCA 0RXD/UCA0SOMI
P3.3/UCB 0CLK/UCA 0STE	14	25	P3.4/UCA 0TXD/UCA0SIMO
AVSS	15	24	P4.7/TBCLK
AVCC	16	23	P4.6/TBOUTH/A15/OA1I3
P4.0/TB0	17	22	P4.5/TB2/A14/OA0I3
P4.1/TB1	18	21	P4.4/TB1/A13/OA1O
P4.2/TB2	19	20	P4.3/TB0/A12/OA0O

# MSP430x22x2, MSP430x22x4 MIXED SIGNAL MICROCONTROLLER

SLAS504D - JULY 2006 - REVISED MARCH 2010

## MSP430x22x2 device pinout, RHA package

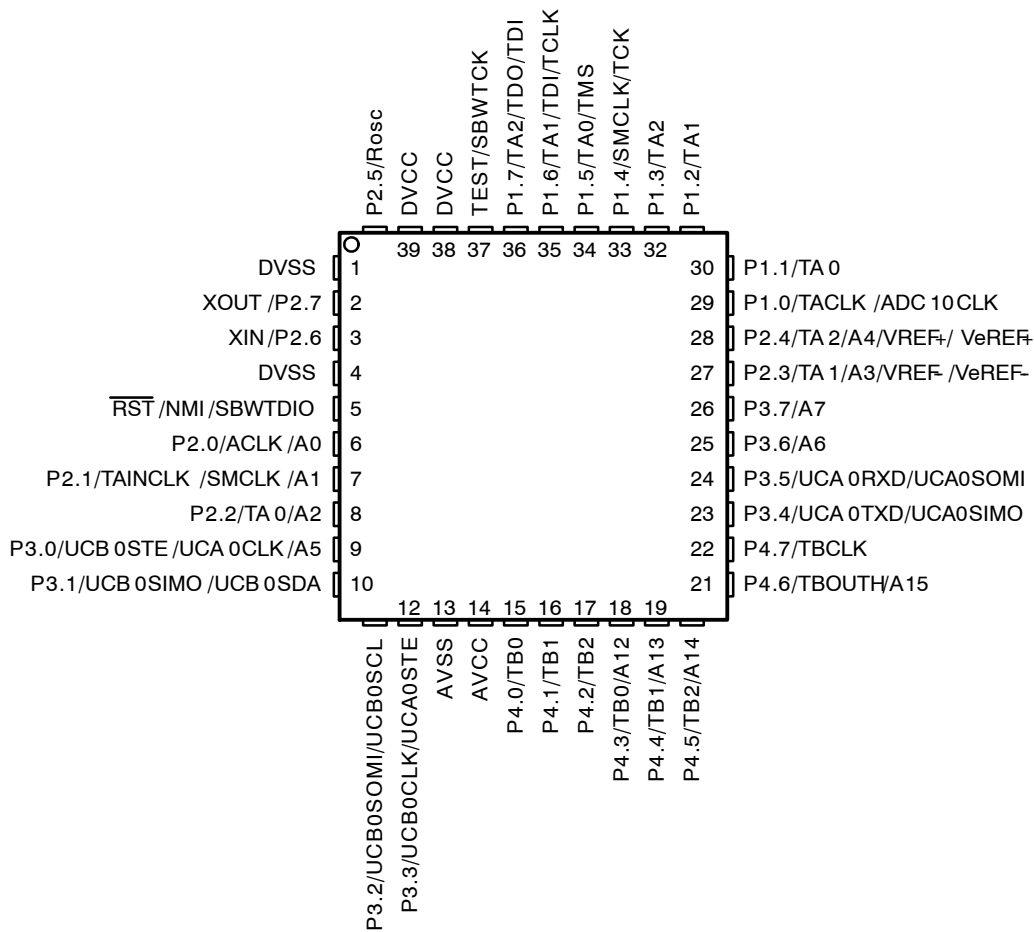

## MSP430x22x4 device pinout, RHA package

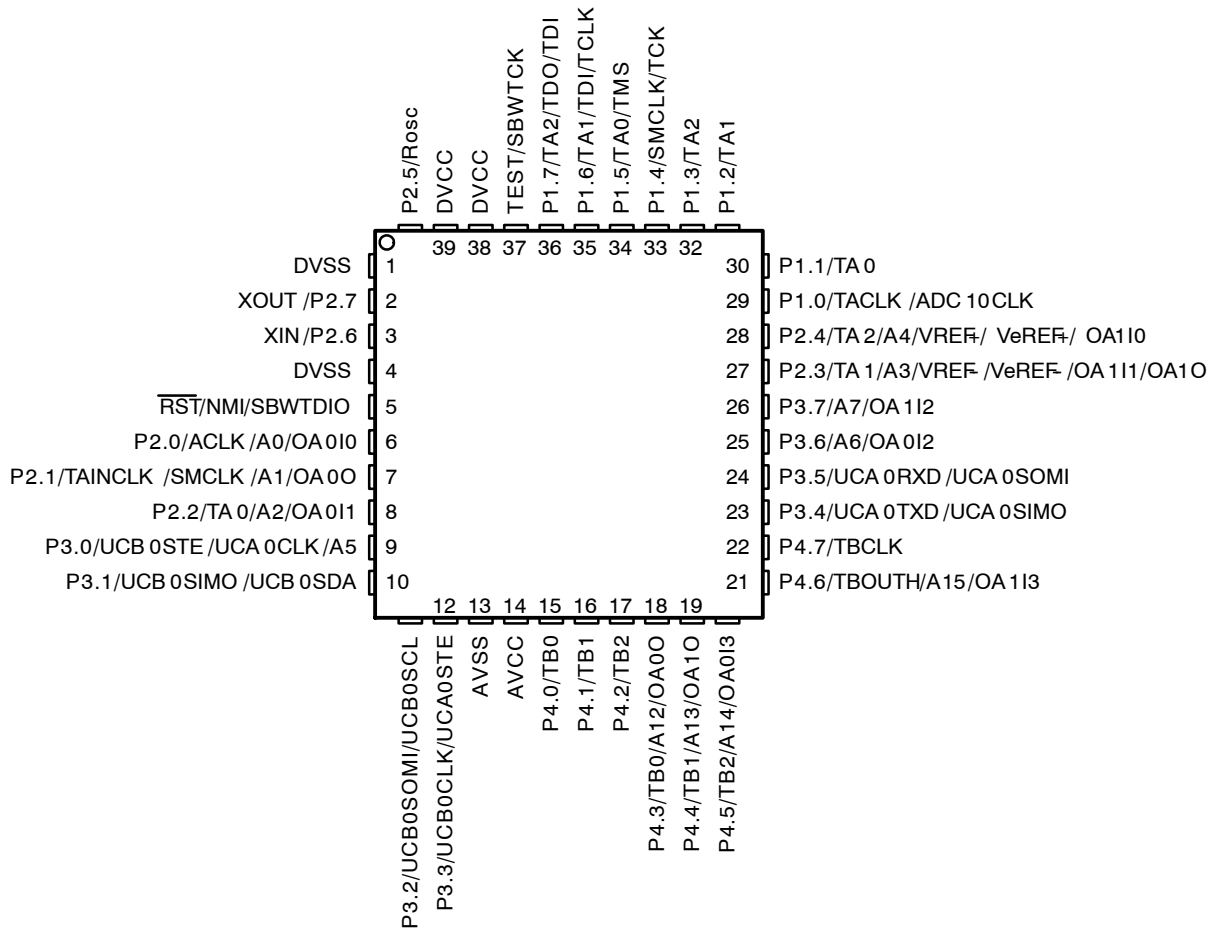

# MSP430x22x2, MSP430x22x4 MIXED SIGNAL MICROCONTROLLER

SLAS504D - JULY 2006 - REVISED MARCH 2010

## MSP430x22x2 functional block diagram

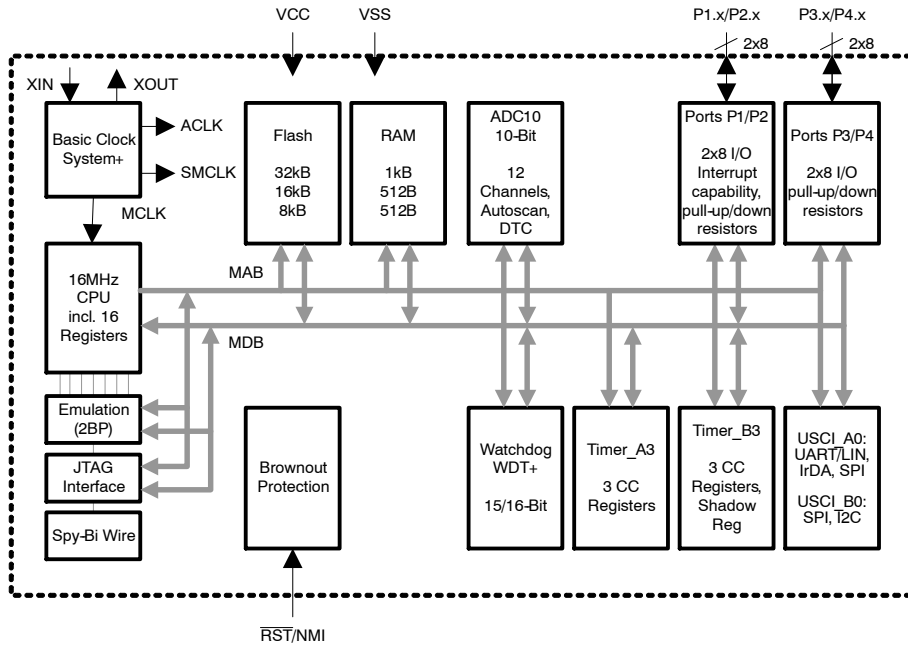

NOTE: See port schematics section for detailed I/O information.

## MSP430x22x4 functional block diagram

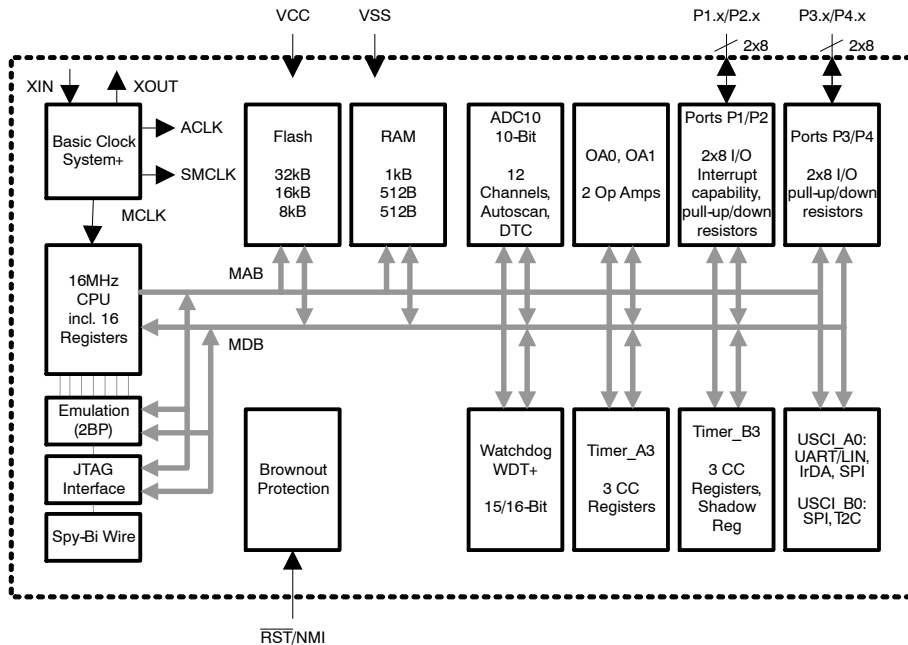

NOTE: See port schematics section for detailed I/O information.



# MSP430x22x2, MSP430x22x4 MIXED SIGNAL MICROCONTROLLER

SLAS504D - JULY 2006 - REVISED MARCH 2010

## Terminal Functions, MSP430x22x2

TERMINAL				DESCRIPTION
NAME	DA NO.	RHA NO.	I/O	
P1.0/TACLK/ ADC10CLK	31	29	I/O	General-purpose digital I/O pin Timer_A, clock signal TACLK input ADC10, conversion clock
P1.1/TA0	32	30	I/O	General-purpose digital I/O pin Timer_A, capture: CCI0A input, compare: OUT0 output/BSL transmit
P1.2/TA1	33	31	I/O	General-purpose digital I/O pin Timer_A, capture: CCI1A input, compare: OUT1 output
P1.3/TA2	34	32	I/O	General-purpose digital I/O pin Timer_A, capture: CCI2A input, compare: OUT2 output
P1.4/SMCLK/ TCK	35	33	I/O	General-purpose digital I/O pin / SMCLK signal output Test Clock input for device programming and test
P1.5/TA0/ TMS	36	34	I/O	General-purpose digital I/O pin / Timer_A, compare: OUT0 output Test Mode Select input for device programming and test
P1.6/TA1/ TDI/TCLK	37	35	I/O	General-purpose digital I/O pin / Timer_A, compare: OUT1 output Test Data Input or Test Clock Input for programming and test
P1.7/TA2/ TDO/TDI†	38	36	I/O	General-purpose digital I/O pin / Timer_A, compare: OUT2 output Test Data Output or Test Data Input for programming and test
P2.0/ACLK/A0	8	6	I/O	General-purpose digital I/O pin / ACLK output ADC10, analog input A0
P2.1/TAINCLK/SMCLK/A1	9	7	I/O	General-purpose digital I/O pin Timer_A, clock signal at INCLK, SMCLK signal output ADC10, analog input A1
P2.2/TA0/A2	10	8	I/O	General-purpose digital I/O pin Timer_A, capture: CCI0B input/BSL receive, compare: OUT0 output ADC10, analog input A2
P2.3/TA1/ A3/V <sub>REF-</sub> /V <sub>eREF-</sub>	29	27	I/O	General-purpose digital I/O pin Timer_A, capture CCI1B input, compare: OUT1 output ADC10, analog input A3 / negative reference voltage output/input
P2.4/TA2/ A4/V <sub>REF+</sub> /V <sub>eREF+</sub>	30	28	I/O	General-purpose digital I/O pin / Timer_A, compare: OUT2 output ADC10, analog input A4 / positive reference voltage output/input
P2.5/ R <sub>OSC</sub>	3	40	I/O	General-purpose digital I/O pin Input for external DCO resistor to define DCO frequency
XIN/P2.6	6	3	I/O	Input terminal of crystal oscillator General-purpose digital I/O pin
XOUT/P2.7	5	2	I/O	Output terminal of crystal oscillator General-purpose digital I/O pin
P3.0/ UCB0STE/UCA0CLK/ A5	11	9	I/O	General-purpose digital I/O pin USCI_B0 slave transmit enable / USCI_A0 clock input/output ADC10, analog input A5
P3.1/ UCB0SIMO/UCB0SDA	12	10	I/O	General-purpose digital I/O pin USCI_B0 slave in/master out in SPI mode, SDA I <sup>2</sup> C data in I <sup>2</sup> C mode
P3.2/ UCB0SOMI/UCB0SCL	13	11	I/O	General-purpose digital I/O pin USCI_B0 slave out/master in in SPI mode, SCL I <sup>2</sup> C clock in I <sup>2</sup> C mode
P3.3/ UCB0CLK/UCA0STE	14	12	I/O	General-purpose digital I/O pin USCI_B0 clock input/output / USCI_A0 slave transmit enable
P3.4/ UCA0TXD/UCA0SIMO	25	23	I/O	General-purpose digital I/O pin USCI_A0 transmit data output in UART mode, slave in/master out in SPI mode



# MSP430x22x2, MSP430x22x4 MIXED SIGNAL MICROCONTROLLER

SLAS504D - JULY 2006 - REVISED MARCH 2010

## Terminal Functions, MSP430x22x2 (Continued)

TERMINAL				DESCRIPTION
NAME	DA NO.	RHA NO.	I/O	
P3.5/ UCA0RXD/UCA0SOMI	26	24	I/O	General-purpose digital I/O pin USCI_A0 receive data input in UART mode, slave out/master in in SPI mode
P3.6/A6	27	25	I/O	General-purpose digital I/O pin ADC10 analog input A6
P3.7/A7	28	26	I/O	General-purpose digital I/O pin ADC10 analog input A7
P4.0/TB0	17	15	I/O	General-purpose digital I/O pin Timer_B, capture: CCI0A input, compare: OUT0 output
P4.1/TB1	18	16	I/O	General-purpose digital I/O pin Timer_B, capture: CCI1A input, compare: OUT1 output
P4.2/TB2	19	17	I/O	General-purpose digital I/O pin Timer_B, capture: CCI2A input, compare: OUT2 output
P4.3/TB0/ A12	20	18	I/O	General-purpose digital I/O pin Timer_B, capture: CCI0B input, compare: OUT0 output ADC10 analog input A12
P4.4/TB1 A13	21	19	I/O	General-purpose digital I/O pin Timer_B, capture: CCI1B input, compare: OUT1 output ADC10 analog input A13
P4.5/TB2 A14	22	20	I/O	General-purpose digital I/O pin Timer_B, compare: OUT2 output ADC10 analog input A14
P4.6/TBOUTH A15	23	21	I/O	General-purpose digital I/O pin Timer_B, switch all TB0 to TB3 outputs to high impedance ADC10 analog input A15
P4.7/TBCLK	24	22	I/O	General-purpose digital I/O pin Timer_B, clock signal TBCLK input
RST/NMI/SBWTIO	7	5	I	Reset or nonmaskable interrupt input Spy-Bi-Wire test data input/output during programming and test
TEST/SBWTCK	1	37	I	Selects test mode for JTAG pins on Port1. The device protection fuse is connected to TEST. Spy-Bi-Wire test clock input during programming and test
DV <sub>CC</sub>	2	38, 39		Digital supply voltage
AV <sub>CC</sub>	16	14		Analog supply voltage
DV <sub>SS</sub>	4	1, 4		Digital ground reference
AV <sub>SS</sub>	15	13		Analog ground reference
QFN Pad	NA	Package Pad	NA	QFN package pad; connection to DV <sub>SS</sub> recommended.

† TDO or TDI is selected via JTAG instruction.

NOTE: If XOUT/P2.7/CA7 is used as an input, excess current will flow until P2SEL.7 is cleared. This is due to the oscillator output driver connection to this pad after reset.





# MSP430x22x2, MSP430x22x4 MIXED SIGNAL MICROCONTROLLER

SLAS504D - JULY 2006 - REVISED MARCH 2010

## Terminal Functions, MSP430x22x4

TERMINAL				DESCRIPTION
NAME	DA NO.	RHA NO.	I/O	
P1.0/TACLK/ ADC10CLK	31	29	I/O	General-purpose digital I/O pin Timer_A, clock signal TACLK input ADC10, conversion clock
P1.1/TA0	32	30	I/O	General-purpose digital I/O pin Timer_A, capture: CCI0A input, compare: OUT0 output/BSL transmit
P1.2/TA1	33	31	I/O	General-purpose digital I/O pin Timer_A, capture: CCI1A input, compare: OUT1 output
P1.3/TA2	34	32	I/O	General-purpose digital I/O pin Timer_A, capture: CCI2A input, compare: OUT2 output
P1.4/SMCLK/ TCK	35	33	I/O	General-purpose digital I/O pin / SMCLK signal output Test Clock input for device programming and test
P1.5/TA0/ TMS	36	34	I/O	General-purpose digital I/O pin / Timer_A, compare: OUT0 output Test Mode Select input for device programming and test
P1.6/TA1/ TDI/TCLK	37	35	I/O	General-purpose digital I/O pin / Timer_A, compare: OUT1 output Test Data Input or Test Clock Input for programming and test
P1.7/TA2/ TDO/TDI†	38	36	I/O	General-purpose digital I/O pin / Timer_A, compare: OUT2 output Test Data Output or Test Data Input for programming and test
P2.0/ACLK/A0/OA0IO	8	6	I/O	General-purpose digital I/O pin / ACLK output ADC10, analog input A0 / OA0, analog input I0
P2.1/TAINCLK/SMCLK/ A1/OA0O	9	7	I/O	General-purpose digital I/O pin / Timer_A, clock signal at INCLK SMCLK signal output ADC10, analog input A1 / OA0, analog output
P2.2/TA0/ A2/OA0I1	10	8	I/O	General-purpose digital I/O pin Timer_A, capture: CCI0B input/BSL receive, compare: OUT0 output ADC10, analog input A2 / OA0, analog input I1
P2.3/TA1/ A3/V <sub>REF-</sub> /V <sub>eREF-</sub> / OA1I1/OA1O	29	27	I/O	General-purpose digital I/O pin Timer_A, capture CCI1B input, compare: OUT1 output ADC10, analog input A3 / negative reference voltage output/input OA1, analog input I1 / OA1, analog output
P2.4/TA2/ A4/V <sub>REF+</sub> /V <sub>eREF+</sub> / OA1I0	30	28	I/O	General-purpose digital I/O pin / Timer_A, compare: OUT2 output ADC10, analog input A4 / positive reference voltage output/input OA1, analog input I0
P2.5/ R <sub>OSC</sub>	3	40	I/O	General-purpose digital I/O pin Input for external DCO resistor to define DCO frequency
XIN/P2.6	6	3	I/O	Input terminal of crystal oscillator General-purpose digital I/O pin
XOUT/P2.7	5	2	I/O	Output terminal of crystal oscillator General-purpose digital I/O pin
P3.0/ UCB0STE/UCA0CLK/ A5	11	9	I/O	General-purpose digital I/O pin USCI_B0 slave transmit enable / USCI_A0 clock input/output ADC10, analog input A5
P3.1/ UCB0SIMO/UCB0SDA	12	10	I/O	General-purpose digital I/O pin USCI_B0 slave in/master out in SPI mode, SDA I <sup>2</sup> C data in I <sup>2</sup> C mode
P3.2/ UCB0SOMI/UCB0SCL	13	11	I/O	General-purpose digital I/O pin USCI_B0 slave out/master in in SPI mode, SCL I <sup>2</sup> C clock in I <sup>2</sup> C mode
P3.3/ UCB0CLK/UCA0STE	14	12	I/O	General-purpose digital I/O pin USCI_B0 clock input/output / USCI_A0 slave transmit enable
P3.4/ UCA0TXD/UCA0SIMO	25	23	I/O	General-purpose digital I/O pin USCI_A0 transmit data output in UART mode, slave in/master out in SPI mode



# MSP430x22x2, MSP430x22x4 MIXED SIGNAL MICROCONTROLLER

SLAS504D - JULY 2006 - REVISED MARCH 2010

## Terminal Functions, MSP430x22x4 (Continued)

TERMINAL				DESCRIPTION
NAME	DA NO.	RHA NO.	I/O	
P3.5/ UCA0RXD/UCA0SOMI	26	24	I/O	General-purpose digital I/O pin USCI_A0 receive data input in UART mode, slave out/master in in SPI mode
P3.6/A6/OA0I2	27	25	I/O	General-purpose digital I/O pin ADC10 analog input A6 / OA0 analog input I2
P3.7/A7/OA1I2	28	26	I/O	General-purpose digital I/O pin ADC10 analog input A7 / OA1 analog input I2
P4.0/TB0	17	15	I/O	General-purpose digital I/O pin Timer_B, capture: CCI0A input, compare: OUT0 output
P4.1/TB1	18	16	I/O	General-purpose digital I/O pin Timer_B, capture: CCI1A input, compare: OUT1 output
P4.2/TB2	19	17	I/O	General-purpose digital I/O pin Timer_B, capture: CCI2A input, compare: OUT2 output
P4.3/TB0/ A12/OA0O	20	18	I/O	General-purpose digital I/O pin Timer_B, capture: CCI0B input, compare: OUT0 output ADC10 analog input A12 / OA0 analog output
P4.4/TB1 A13/OA1O	21	19	I/O	General-purpose digital I/O pin Timer_B, capture: CCI1B input, compare: OUT1 output ADC10 analog input A13 / OA1 analog output
P4.5/TB2 A14/OA0I3	22	20	I/O	General-purpose digital I/O pin Timer_B, compare: OUT2 output ADC10 analog input A14 / OA0 analog input I3
P4.6/TBOUTH A15/OA1I3	23	21	I/O	General-purpose digital I/O pin Timer_B, switch all TB0 to TB3 outputs to high impedance ADC10 analog input A15 / OA1 analog input I3
P4.7/TBCLK	24	22	I/O	General-purpose digital I/O pin Timer_B, clock signal TBCLK input
RST/NMI/SBWTIO	7	5	I	Reset or nonmaskable interrupt input Spy-Bi-Wire test data input/output during programming and test
TEST/SBWTCK	1	37	I	Selects test mode for JTAG pins on Port1. The device protection fuse is connected to TEST. Spy-Bi-Wire test clock input during programming and test
DV <sub>CC</sub>	2	38, 39		Digital supply voltage
AV <sub>CC</sub>	16	14		Analog supply voltage
DV <sub>SS</sub>	4	1, 4		Digital ground reference
AV <sub>SS</sub>	15	13		Analog ground reference
QFN Pad	NA	Package Pad	NA	QFN package pad connection to DV <sub>SS</sub> recommended.

† TDO or TDI is selected via JTAG instruction.

NOTE: If XOUT/P2.7/CA7 is used as an input, excess current will flow until P2SEL.7 is cleared. This is due to the oscillator output driver connection to this pad after reset.



## short-form description

### CPU

The MSP430 CPU has a 16-bit RISC architecture that is highly transparent to the application. All operations, other than program-flow instructions, are performed as register operations in conjunction with seven addressing modes for source operand and four addressing modes for destination operand.

The CPU is integrated with 16 registers that provide reduced instruction execution time. The register-to-register operation execution time is one cycle of the CPU clock.

Four of the registers, R0 to R3, are dedicated as program counter, stack pointer, status register, and constant generator respectively. The remaining registers are general-purpose registers.

Peripherals are connected to the CPU using data, address, and control buses, and can be handled with all instructions.

### instruction set

The instruction set consists of 51 instructions with three formats and seven address modes. Each instruction can operate on word and byte data. Table 1 shows examples of the three types of instruction formats; the address modes are listed in Table 2.

Program Counter	PC/R0
Stack Pointer	SP/R1
Status Register	SR/CG1/R2
Constant Generator	CG2/R3
General-Purpose Register	R4
General-Purpose Register	R5
General-Purpose Register	R6
General-Purpose Register	R7
General-Purpose Register	R8
General-Purpose Register	R9
General-Purpose Register	R10
General-Purpose Register	R11
General-Purpose Register	R12
General-Purpose Register	R13
General-Purpose Register	R14
General-Purpose Register	R15

Table 1. Instruction Word Formats

Dual operands, source-destination	e.g., ADD R4,R5	R4 + R5 ---> R5
Single operands, destination only	e.g., CALL R8	PC --> (TOS), R8--> PC
Relative jump, un/conditional	e.g., JNE	Jump-on-equal bit = 0

Table 2. Address Mode Descriptions

ADDRESS MODE	S	D	SYNTAX	EXAMPLE	OPERATION
Register	●	●	MOV Rs,Rd	MOV R10,R11	R10 --> R11
Indexed	●	●	MOV X(Rn),Y(Rm)	MOV 2(R5),6(R6)	M(2+R5)--> M(6+R6)
Symbolic (PC relative)	●	●	MOV EDE,TONI		M(EDE) --> M(TONI)
Absolute	●	●	MOV &MEM,&TCDAT		M(MEM) --> M(TCDAT)
Indirect	●		MOV @Rn,Y(Rm)	MOV @R10,Tab(R6)	M(R10) --> M(Tab+R6)
Indirect autoincrement	●		MOV @Rn+,Rm	MOV @R10+,R11	M(R10) --> R11 R10 + 2--> R10
Immediate	●		MOV #X,TONI	MOV #45,TONI	#45 --> M(TONI)

NOTE: S = source D = destination

# MSP430x22x2, MSP430x22x4 MIXED SIGNAL MICROCONTROLLER

SLAS504D - JULY 2006 - REVISED MARCH 2010

---

## operating modes

The MSP430 has one active mode and five software selectable low-power modes of operation. An interrupt event can wake up the device from any of the five low-power modes, service the request, and restore back to the low-power mode on return from the interrupt program.

The following six operating modes can be configured by software:

- Active mode (AM)
  - All clocks are active
- Low-power mode 0 (LPM0)
  - CPU is disabled
  - ACLK and SMCLK remain active
  - MCLK is disabled
- Low-power mode 1 (LPM1)
  - CPU is disabled
  - ACLK and SMCLK remain active
  - MCLK is disabled
  - DCO's dc-generator is disabled if DCO not used in active mode
- Low-power mode 2 (LPM2)
  - CPU is disabled
  - MCLK and SMCLK are disabled
  - DCO's dc generator remains enabled
  - ACLK remains active
- Low-power mode 3 (LPM3)
  - CPU is disabled
  - MCLK and SMCLK are disabled
  - DCO's dc generator is disabled
  - ACLK remains active
- Low-power mode 4 (LPM4)
  - CPU is disabled
  - ACLK is disabled
  - MCLK and SMCLK are disabled
  - DCO's dc generator is disabled
  - Crystal oscillator is stopped



POST OFFICE BOX 655303 • DALLAS, TEXAS 75265

**interrupt vector addresses**

The interrupt vectors and the power-up starting address are located in the address range of 0FFFFh to 0FFC0h. The vector contains the 16-bit address of the appropriate interrupt handler instruction sequence.

If the reset vector (located at address 0FFFEh) contains 0FFFFh (e.g., flash is not programmed) the CPU goes into LPM4 immediately after power up.

INTERRUPT SOURCE	INTERRUPT FLAG	SYSTEM INTERRUPT	WORD ADDRESS	PRIORITY
Power-up External reset Watchdog Flash key violation PC out-of-range (see Note 1)	PORIFG RSTIFG WDTIFG KEYV (see Note 2)	Reset	0FFFEh	31, highest
NMI Oscillator fault Flash memory access violation	NMIIFG OFIFG ACCVIFG (see Notes 2 & 4)	(non)-maskable, (non)-maskable, (non)-maskable	0FFFCh	30
Timer_B3	TBCCR0 CCIFG (see Note 3)	maskable	0FFFAh	29
Timer_B3	TBCCR1 and TBCCR2 CCIFGs, TBIFG (see Notes 2 and 3)	maskable	0FFF8h	28
			0FFF6h	27
Watchdog Timer	WDTIFG	maskable	0FFF4h	26
Timer_A3	TACCR0 CCIFG (see Note 3)	maskable	0FFF2h	25
Timer_A3	TACCR1 CCIFG. TACCR2 CCIFG TAIFG (see Notes 2 and 3)	maskable	0FFF0h	24
USCI_A0/USCI_B0 Receive	UCA0RXIFG, UCB0RXIFG (see Notes 2)	maskable	0FFEEh	23
USCI_A0/USCI_B0 Transmit	UCA0TXIFG, UCB0TXIFG (see Notes 2)	maskable	0FFECh	22
ADC10	ADC10IFG (see Note 3)	maskable	0FFEAh	21
			0FFE8h	20
I/O Port P2 (eight flags)	P2IFG.0 to P2IFG.7 (see Notes 2 and 3)	maskable	0FFE6h	19
I/O Port P1 (eight flags)	P1IFG.0 to P1IFG.7 (see Notes 2 and 3)	maskable	0FFE4h	18
			0FFE2h	17
			0FFE0h	16
(see Note 5)			0FFDEh	15
(see Note 6)			0FFDCh ... 0FFC0h	14 ... 0, lowest

- NOTES: 1. A reset is generated if the CPU tries to fetch instructions from within the module register memory address range (0h to 01FFh) or from within unused address ranges.
2. Multiple source flags
3. Interrupt flags are located in the module.
4. (non)-maskable: the individual interrupt-enable bit can disable an interrupt event, but the general interrupt enable cannot. Nonmaskable: neither the individual nor the general interrupt-enable bit will disable an interrupt event.
5. This location is used as bootstrap loader security key (BSLSKEY).  
A 0AA55h at this location disables the BSL completely.  
A zero (0h) disables the erasure of the flash if an invalid password is supplied.
6. The interrupt vectors at addresses 0FFDCh to 0FFC0h are not used in this device and can be used for regular program code if necessary.

# MSP430x22x2, MSP430x22x4 MIXED SIGNAL MICROCONTROLLER

SLAS504D - JULY 2006 - REVISED MARCH 2010

## special function registers

Most interrupt and module enable bits are collected into the lowest address space. Special function register bits not allocated to a functional purpose are not physically present in the device. Simple software access is provided with this arrangement.

### interrupt enable 1 and 2

Address	7	6	5	4	3	2	1	0
00h			ACCVIE	NMIIE			OFIE	WDTIE
			rw-0	rw-0			rw-0	rw-0

- WDTIE      Watchdog Timer interrupt enable. Inactive if watchdog mode is selected. Active if Watchdog Timer is configured in interval timer mode.
- OFIE      Oscillator fault enable
- NMIIE      (Non)-maskable interrupt enable
- ACCVIE      Flash access violation interrupt enable

Address	7	6	5	4	3	2	1	0
01h					UCB0TXIE	UCB0RXIE	UCA0TXIE	UCA0RXIE
					rw-0	rw-0	rw-0	rw-0

- UCA0RXIE      USCI\_A0 receive-interrupt enable
- UCA0TXIE      USCI\_A0 transmit-interrupt enable
- UCB0RXIE      USCI\_B0 receive-interrupt enable
- UCB0TXIE      USCI\_B0 transmit-interrupt enable



interrupt flag register 1 and 2

Address	7	6	5	4	3	2	1	0
02h				NMIIFG	RSTIFG	PORIFG	OFIFG	WDTIFG
				rw-0	rw-(0)	rw-(1)	rw-1	rw-(0)

- WDTIFG Set on Watchdog Timer overflow (in watchdog mode) or security key violation. Reset on V<sub>CC</sub> power up or a reset condition at  $\overline{\text{RST}}$ /NMI pin in reset mode.
- OFIFG Flag set on oscillator fault
- RSTIFG External reset interrupt flag. Set on a reset condition at  $\overline{\text{RST}}$ /NMI pin in reset mode. Reset on V<sub>CC</sub> power up.
- PORIFG Power-On interrupt flag. Set on V<sub>CC</sub> power up.
- NMIIFG Set via  $\overline{\text{RST}}$ /NMI-pin

Address	7	6	5	4	3	2	1	0
03h					UCB0 TXIFG	UCB0 RXIFG	UCA0 TXIFG	UCA0 RXIFG
					rw-1	rw-0	rw-1	rw-0

- UCA0RXIFG USCI\_A0 receive-interrupt flag
- UCA0TXIFG USCI\_A0 transmit-interrupt flag
- UCB0RXIFG USCI\_B0 receive-interrupt flag
- UCB0TXIFG USCI\_B0 transmit-interrupt flag

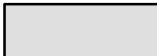
- Legend**
- rw: Bit can be read and written.
  - rw-0,1: Bit can be read and written. It is reset or set by PUC.
  - rw-(0,1): Bit can be read and written. It is reset or set by POR.
  -  SFR bit is not present in device.

# MSP430x22x2, MSP430x22x4 MIXED SIGNAL MICROCONTROLLER

SLAS504D - JULY 2006 - REVISED MARCH 2010

## memory organization

		MSP430F223x	MSP430F225x	MSP430F227x
Memory	Size	8KB Flash	16KB Flash	32KB Flash
Main: interrupt vector	Flash	0FFFFh-0FFC0h	0FFFFh-0FFC0h	0FFFFh-0FFC0h
Main: code memory	Flash	0FFFFh-0E000h	0FFFFh-0C000h	0FFFFh-08000h
Information memory	Size	256 Byte	256 Byte	256 Byte
	Flash	010FFh-01000h	010FFh-01000h	010FFh-01000h
Boot memory	Size	1KB	1KB	1KB
	ROM	0FFFh-0C00h	0FFFh-0C00h	0FFFh-0C00h
RAM	Size	512 Byte	512 Byte	1KB
		03FFh-0200h	03FFh-0200h	05FFh-0200h
Peripherals	16-bit	01FFh-0100h	01FFh-0100h	01FFh-0100h
	8-bit	0FFh-010h	0FFh-010h	0FFh-010h
	8-bit SFR	0Fh-00h	0Fh-00h	0Fh-00h

## bootstrap loader (BSL)

The MSP430 bootstrap loader (BSL) enables users to program the flash memory or RAM using a UART serial interface. Access to the MSP430 memory via the BSL is protected by user-defined password. For complete description of the features of the BSL and its implementation, see the *MSP430 Memory Programming User's Guide*, literature number SLAU265.

BSL FUNCTION	DA PACKAGE PINS	RHA PACKAGE PINS
Data transmit	32 - P1.1	30 - P1.1
Data receive	10 - P2.2	8 - P2.2

## flash memory

The flash memory can be programmed via the JTAG port, the bootstrap loader, or in-system by the CPU. The CPU can perform single-byte and single-word writes to the flash memory. Features of the flash memory include:

- Flash memory has n segments of main memory and four segments of information memory (A to D) of 64 bytes each. Each segment in main memory is 512 bytes in size.
- Segments 0 to n may be erased in one step, or each segment may be individually erased.
- Segments A to D can be erased individually, or as a group with segments 0 to n. Segments A to D are also called *information memory*.
- Segment A contains calibration data. After reset, segment A is protected against programming or erasing. It can be unlocked, but care should be taken not to erase this segment if the calibration data is required.





## peripherals

Peripherals are connected to the CPU through data, address, and control busses and can be handled using all instructions. For complete module descriptions, refer to the *MSP430x2xx Family User's Guide*.

## oscillator and system clock

The clock system is supported by the basic clock module that includes support for a 32768-Hz watch crystal oscillator, an internal very low power, low frequency oscillator, an internal digitally-controlled oscillator (DCO), and a high frequency crystal oscillator. The basic clock module is designed to meet the requirements of both low system cost and low power consumption. The internal DCO provides a fast turn-on clock source and stabilizes in less than 1  $\mu$ s. The basic clock module provides the following clock signals:

- Auxiliary clock (ACLK), sourced from a 32768-Hz watch crystal, a high frequency crystal, or the internal very low power LF oscillator.
- Main clock (MCLK), the system clock used by the CPU.
- Sub-Main clock (SMCLK), the sub-system clock used by the peripheral modules.

DCO Calibration Data (provided from factory in flash info memory segment A)			
DCO Frequency	Calibration Register	Size	Address
1 MHz	CALBC1_1MHZ	byte	010FFh
	CALDCO_1MHZ	byte	010FEh
8 MHz	CALBC1_8MHZ	byte	010FDh
	CALDCO_8MHZ	byte	010FCh
12 MHz	CALBC1_12MHZ	byte	010FBh
	CALDCO_12MHZ	byte	010FAh
16 MHz	CALBC1_16MHZ	byte	010F9h
	CALDCO_16MHZ	byte	010F8h

## brownout

The brownout circuit is implemented to provide the proper internal reset signal to the device during power on and power off.

## digital I/O

There are four 8-bit I/O ports implemented—ports P1, P2, P3, and P4:

- All individual I/O bits are independently programmable.
- Any combination of input, output, and interrupt conditions is possible.
- Edge-selectable interrupt input capability for all the eight bits of port P1 and P2.
- Read/write access to port-control registers is supported by all instructions.
- Each I/O has an individually programmable pullup/pulldown resistor.

## watchdog timer (WDT+)

The primary function of the WDT+ module is to perform a controlled system restart after a software problem occurs. If the selected time interval expires, a system reset is generated. If the watchdog function is not needed in an application, the module can be configured as an interval timer and can generate interrupts at selected time intervals.

# MSP430x22x2, MSP430x22x4 MIXED SIGNAL MICROCONTROLLER

SLAS504D - JULY 2006 - REVISED MARCH 2010

## timer\_A3

Timer\_A3 is a 16-bit timer/counter with three capture/compare registers. Timer\_A3 can support multiple capture/compares, PWM outputs, and interval timing. Timer\_A3 also has extensive interrupt capabilities. Interrupts may be generated from the counter on overflow conditions and from each of the capture/compare registers.

Timer_A3 Signal Connections							
Input Pin Number		Device Input Signal	Module Input Name	Module Block	Module Output Signal	Output Pin Number	
DA	RHA					DA	RHA
31 - P1.0	29 - P1.0	TACLK	TACLK	Timer	NA		
		ACLK	ACLK				
		SMCLK	SMCLK				
9 - P2.1	7 - P2.1	TAINCLK	INCLK				
32 - P1.1	30 - P1.1	TA0	CCI0A	CCR0	TA0	32 - P1.1	30 - P1.1
10 - P2.2	8 - P2.2	TA0	CCI0B			10 - P2.2	8 - P2.2
		V <sub>SS</sub>	GND			36 - P1.5	34 - P1.5
		V <sub>CC</sub>	V <sub>CC</sub>				
33 - P1.2	31 - P1.2	TA1	CCI1A	CCR1	TA1	33 - P1.2	31 - P1.2
29 - P2.3	27 - P2.3	TA1	CCI1B			29 - P2.3	27 - P2.3
		V <sub>SS</sub>	GND			37 - P1.6	35 - P1.6
		V <sub>CC</sub>	V <sub>CC</sub>				
34 - P1.3	32 - P1.3	TA2	CCI2A	CCR2	TA2	34 - P1.3	32 - P1.3
		ACLK (internal)	CCI2B			30 - P2.4	28 - P2.4
		V <sub>SS</sub>	GND			38 - P1.7	36 - P1.7
		V <sub>CC</sub>	V <sub>CC</sub>				

## timer\_B3

Timer\_B3 is a 16-bit timer/counter with three capture/compare registers. Timer\_B3 can support multiple capture/compares, PWM outputs, and interval timing. Timer\_B3 also has extensive interrupt capabilities. Interrupts may be generated from the counter on overflow conditions and from each of the capture/compare registers.

Timer_B3 Signal Connections							
Input Pin Number		Device Input Signal	Module Input Name	Module Block	Module Output Signal	Output Pin Number	
DA	RHA					DA	RHA
24 - P4.7	22 - P4.7	TBCLK	TBCLK	Timer	NA		
		ACLK	ACLK				
		SMCLK	SMCLK				
24 - P4.7	22 - P4.7	TBCLK	INCLK				
17 - P4.0	15 - P4.0	TB0	CCI0A	CCR0	TB0	17 - P4.0	15 - P4.0
20 - P4.3	18 - P4.3	TB0	CCI0B			20 - P4.3	18 - P4.3
		V <sub>SS</sub>	GND				
		V <sub>CC</sub>	V <sub>CC</sub>				
18 - P4.1	16 - P4.1	TB1	CCI1A	CCR1	TB1	18 - P4.1	16 - P4.1
21 - P4.4	19 - P4.4	TB1	CCI1B			21 - P4.4	19 - P4.4
		V <sub>SS</sub>	GND				
		V <sub>CC</sub>	V <sub>CC</sub>				
19 - P4.2	17 - P4.2	TB2	CCI2A	CCR2	TB2	19 - P4.2	17 - P4.2
		ACLK (internal)	CCI2B			22 - P4.5	20 - P4.5
		V <sub>SS</sub>	GND				
		V <sub>CC</sub>	V <sub>CC</sub>				

## universal serial communications interface (USCI)

The USCI module is used for serial data communication. The USCI module supports synchronous communication protocols like SPI (3 or 4 pin), I<sup>2</sup>C and asynchronous communication protocols such as UART, enhanced UART with automatic baudrate detection (LIN), and IrDA.

USCI\_A0 provides support for SPI (3 or 4 pin), UART, enhanced UART, and IrDA.

USCI\_B0 provides support for SPI (3 or 4 pin) and I<sup>2</sup>C.

# MSP430x22x2, MSP430x22x4 MIXED SIGNAL MICROCONTROLLER

SLAS504D - JULY 2006 - REVISED MARCH 2010

## ADC10

The ADC10 module supports fast, 10-bit analog-to-digital conversions. The module implements a 10-bit SAR core, sample select control, reference generator and data transfer controller, or DTC, for automatic conversion result handling allowing ADC samples to be converted and stored without any CPU intervention.

## operational amplifier OA (MSP430x22x4 only)

The MSP430x22x4 has two configurable low-current general-purpose operational amplifiers. Each OA input and output terminal is software-selectable and offer a flexible choice of connections for various applications. The OA op amps primarily support front-end analog signal conditioning prior to analog-to-digital conversion.

OA0 Signal Connections			
Analog Input Pin Number		Device Input Signal	Module Input Name
DA	RHA		
8 - A0	6 - A0	OA0I0	OAxI0
10 - A2	8 - A2	OA0I1	OA0I1
10 - A2	8 - A2	OA0I1	OAxI1
27 - A6	25 - A6	OA0I2	OAxIA
22 - A14	20 - A14	OA0I3	OAxIB

OA1 Signal Connections			
Analog Input Pin Number		Device Input Signal	Module Input Name
DA	RHA		
30 - A4	28 - A4	OA1I0	OAxI0
10 - A2	8 - A2	OA0I1	OA0I1
29 - A3	27 - A3	OA1I1	OAxI1
28 - A7	26 - A7	OA1I2	OAxIA
23 - A15	21 - A15	OA1I3	OAxIB



**peripheral file map**

<b>PERIPHERALS WITH WORD ACCESS</b>			
<b>ADC10</b>	ADC data transfer start address	ADC10SA	1BCh
	ADC memory	ADC10MEM	1B4h
	ADC control register 1	ADC10CTL1	1B2h
	ADC control register 0	ADC10CTL0	1B0h
	ADC analog enable 0	ADC10AE0	04Ah
	ADC analog enable 1	ADC10AE1	04Bh
	ADC data transfer control register 1	ADC10DTC1	049h
	ADC data transfer control register 0	ADC10DTC0	048h
<b>Timer_B</b>	Capture/compare register	TBCCR2	0196h
	Capture/compare register	TBCCR1	0194h
	Capture/compare register	TBCCR0	0192h
	Timer_B register	TBR	0190h
	Capture/compare control	TBCCTL2	0186h
	Capture/compare control	TBCCTL1	0184h
	Capture/compare control	TBCCTL0	0182h
	Timer_B control	TBCTL	0180h
Timer_B interrupt vector	TBIV	011Eh	
<b>Timer_A</b>	Capture/compare register	TACCR2	0176h
	Capture/compare register	TACCR1	0174h
	Capture/compare register	TACCR0	0172h
	Timer_A register	TAR	0170h
	Capture/compare control	TACCTL2	0166h
	Capture/compare control	TACCTL1	0164h
	Capture/compare control	TACCTL0	0162h
	Timer_A control	TACTL	0160h
Timer_A interrupt vector	TAIV	012Eh	
<b>Flash Memory</b>	Flash control 3	FCTL3	012Ch
	Flash control 2	FCTL2	012Ah
	Flash control 1	FCTL1	0128h
<b>Watchdog Timer+</b>	Watchdog/timer control	WDTCTL	0120h
<b>PERIPHERALS WITH BYTE ACCESS</b>			
<b>OA1 (MSP430x22x4 only)</b>	Operational Amplifier 1 control register 1	OA1CTL1	0C3h
	Operational Amplifier 1 control register 1	OA1CTL0	0C2h
<b>OA0 (MSP430x22x4 only)</b>	Operational Amplifier 0 control register 1	OA0CTL1	0C1h
	Operational Amplifier 0 control register 1	OA0CTL0	0C0h
<b>USCI_B0</b>	USCI_B0 transmit buffer	UCB0TXBUF	06Fh
	USCI_B0 receive buffer	UCB0RXBUF	06Eh
	USCI_B0 status	UCB0STAT	06Dh
	USCI_B0 bit rate control 1	UCB0BR1	06Bh
	USCI_B0 bit rate control 0	UCB0BR0	06Ah
	USCI_B0 control 1	UCB0CTL1	069h
	USCI_B0 control 0	UCB0CTL0	068h
	USCI_B0 I2C slave address	UCB0SA	011Ah
	USCI_B0 I2C own address	UCB0OA	0118h
<b>USCI_A0</b>	USCI_A0 transmit buffer	UCA0TXBUF	067h
	USCI_A0 receive buffer	UCA0RXBUF	066h
	USCI_A0 status	UCA0STAT	065h
	USCI_A0 modulation control	UCA0MCTL	064h
	USCI_A0 baud rate control 1	UCA0BR1	063h
	USCI_A0 baud rate control 0	UCA0BR0	062h
	USCI_A0 control 1	UCA0CTL1	061h
	USCI_A0 control 0	UCA0CTL0	060h
	USCI_A0 IrDA receive control	UCA0IRRCTL	05Fh
	USCI_A0 IrDA transmit control	UCA0IRTCTL	05Eh
	USCI_A0 auto baud rate control	UCA0ABCTL	05Dh

# MSP430x22x2, MSP430x22x4 MIXED SIGNAL MICROCONTROLLER

SLAS504D - JULY 2006 - REVISED MARCH 2010

PERIPHERALS WITH BYTE ACCESS (continued)			
<b>Basic Clock System+</b>	Basic clock system control 3 Basic clock system control 2 Basic clock system control 1 DCO clock frequency control	BCSCTL3 BCSCTL2 BCSCTL1 DCOCTL	053h 058h 057h 056h
<b>Port P4</b>	Port P4 resistor enable Port P4 selection Port P4 direction Port P4 output Port P4 input	P4REN P4SEL P4DIR P4OUT P4IN	011h 01Fh 01Eh 01Dh 01Ch
<b>Port P3</b>	Port P3 resistor enable Port P3 selection Port P3 direction Port P3 output Port P3 input	P3REN P3SEL P3DIR P3OUT P3IN	010h 01Bh 01Ah 019h 018h
<b>Port P2</b>	Port P2 resistor enable Port P2 selection Port P2 interrupt enable Port P2 interrupt edge select Port P2 interrupt flag Port P2 direction Port P2 output Port P2 input	P2REN P2SEL P2IE P2IES P2IFG P2DIR P2OUT P2IN	02Fh 02Eh 02Dh 02Ch 02Bh 02Ah 029h 028h
<b>Port P1</b>	Port P1 resistor enable Port P1 selection Port P1 interrupt enable Port P1 interrupt edge select Port P1 interrupt flag Port P1 direction Port P1 output Port P1 input	P1REN P1SEL P1IE P1IES P1IFG P1DIR P1OUT P1IN	027h 026h 025h 024h 023h 022h 021h 020h
<b>Special Function</b>	SFR interrupt flag 2 SFR interrupt flag 1 SFR interrupt enable 2 SFR interrupt enable 1	IFG2 IFG1 IE2 IE1	003h 002h 001h 000h



## absolute maximum ratings (see Note 1)

Voltage applied at $V_{CC}$ to $V_{SS}$ .....	-0.3 V to 4.1 V
Voltage applied to any pin (see Note 2) .....	-0.3 V to $V_{CC}+0.3$ V
Diode current at any device terminal .....	$\pm 2$ mA
Storage temperature range, $T_{stg}$ :	
Unprogrammed device (see Note 3) .....	-55°C to 150°C
Programmed device (see Note 3) .....	-55°C to 105°C

- NOTES: 1. Stresses beyond those listed under “absolute maximum ratings” may cause permanent damage to the device. These are stress ratings only, and functional operation of the device at these or any other conditions beyond those indicated under “recommended operating conditions” is not implied. Exposure to absolute-maximum-rated conditions for extended periods may affect device reliability.
2. All voltages referenced to  $V_{SS}$ . The JTAG fuse-blow voltage,  $V_{FB}$ , is allowed to exceed the absolute maximum rating. The voltage is applied to the TEST pin when blowing the JTAG fuse.
3. Higher temperature may be applied during board soldering process according to the current JEDEC J-STD-020 specification with peak reflow temperatures not higher than classified on the device label on the shipping boxes or reels.

## recommended operating conditions

		MIN	NOM	MAX	UNIT
Supply voltage during program execution, $V_{CC}$		1.8		3.6	V
Supply voltage during program/erase flash memory, $V_{CC}$		2.2		3.6	V
Supply voltage, $V_{SS}$			0		V
Operating free-air temperature, $T_A$	I version	-40		85	°C
	T version	-40		105	
Processor frequency, $f_{SYSTEM}$ (maximum MCLK frequency) (see Notes 1 and 2 and Figure 1)	$V_{CC} = 1.8$ V, Duty cycle = 50% $\pm$ 10%	dc		4.15	MHz
	$V_{CC} = 2.7$ V, Duty cycle = 50% $\pm$ 10%	dc		12	
	$V_{CC} \geq 3.3$ V, Duty cycle = 50% $\pm$ 10%	dc		16	

- NOTES: 1. The MSP430 CPU is clocked directly with MCLK.  
Both the high and low phase of MCLK must not exceed the pulse width of the specified maximum frequency.
2. Modules might have a different maximum input clock specification. Refer to the specification of the respective module in this data sheet.

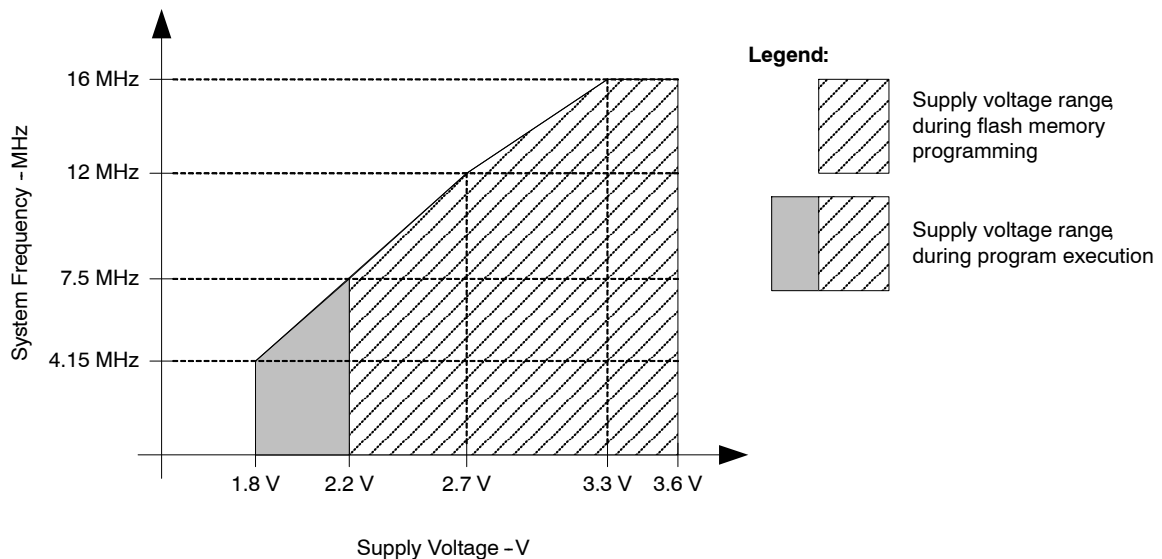

NOTE: Minimum processor frequency is defined by system clock. Flash program or erase operations require a minimum  $V_{CC}$  of 2.2 V.

**Figure 1. Operating Area**

# MSP430x22x2, MSP430x22x4 MIXED SIGNAL MICROCONTROLLER

SLAS504D - JULY 2006 - REVISED MARCH 2010

**electrical characteristics over recommended ranges of supply voltage and operating free-air temperature (unless otherwise noted)**

**active mode supply current (into DV<sub>CC</sub> + AV<sub>CC</sub>) excluding external current (see Notes 1 and 2)**

PARAMETER	TEST CONDITIONS	T <sub>A</sub>	V <sub>CC</sub>	MIN	TYP	MAX	UNIT
I <sub>AM, 1MHz</sub> Active mode (AM) current (1 MHz)	f <sub>DCO</sub> = f <sub>MCLK</sub> = f <sub>SMCLK</sub> = 1 MHz, f <sub>ACLK</sub> = 32,768 Hz, Program executes in flash, BCSCTL1 = CALBC1_1MHZ, DCOCTL = CALDCO_1MHZ, CPUOFF = 0, SCG0 = 0, SCG1 = 0, OSCOFF = 0		2.2 V		270	390	μA
			3 V		390	550	
I <sub>AM, 1MHz</sub> Active mode (AM) current (1 MHz)	f <sub>DCO</sub> = f <sub>MCLK</sub> = f <sub>SMCLK</sub> = 1 MHz, f <sub>ACLK</sub> = 32,768 Hz, Program executes in RAM, BCSCTL1 = CALBC1_1MHZ, DCOCTL = CALDCO_1MHZ, CPUOFF = 0, SCG0 = 0, SCG1 = 0, OSCOFF = 0		2.2 V		240		μA
			3 V		340		
I <sub>AM, 4kHz</sub> Active mode (AM) current (4 kHz)	f <sub>MCLK</sub> = f <sub>SMCLK</sub> = f <sub>ACLK</sub> = 32,768 Hz/8 = 4,096 Hz, f <sub>DCO</sub> = 0 Hz, Program executes in flash, SELMx = 11, SELS = 1, DIVMx = DIVSx = DIVAx = 11, CPUOFF = 0, SCG0 = 1, SCG1 = 0, OSCOFF = 0	-40–85°C	2.2 V		5	9	μA
		105°C	2.2 V			18	
		-40–85°C	3 V		6	10	
		105°C	3 V			20	
I <sub>AM, 100kHz</sub> Active mode (AM) current (100 kHz)	f <sub>MCLK</sub> = f <sub>SMCLK</sub> = f <sub>DCO(0, 0)</sub> ≈ 100 kHz, f <sub>ACLK</sub> = 0 Hz, Program executes in flash, RSELx = 0, DCOx = 0, CPUOFF = 0, SCG0 = 0, SCG1 = 0, OSCOFF = 1	-40–85°C	2.2 V		60	85	μA
		105°C	2.2 V			95	
		-40–85°C	3 V		72	95	
		105°C	3 V			105	

- NOTES: 1. All inputs are tied to 0 V or V<sub>CC</sub>. Outputs do not source or sink any current.  
2. The currents are characterized with a Micro Crystal CC4V-T1A SMD crystal with a load capacitance of 9 pF. The internal and external load capacitance is chosen to closely match the required 9 pF.



electrical characteristics over recommended ranges of supply voltage and operating free-air temperature (unless otherwise noted) (continued)

typical characteristics - active mode supply current (into DV<sub>CC</sub> + AV<sub>CC</sub>)

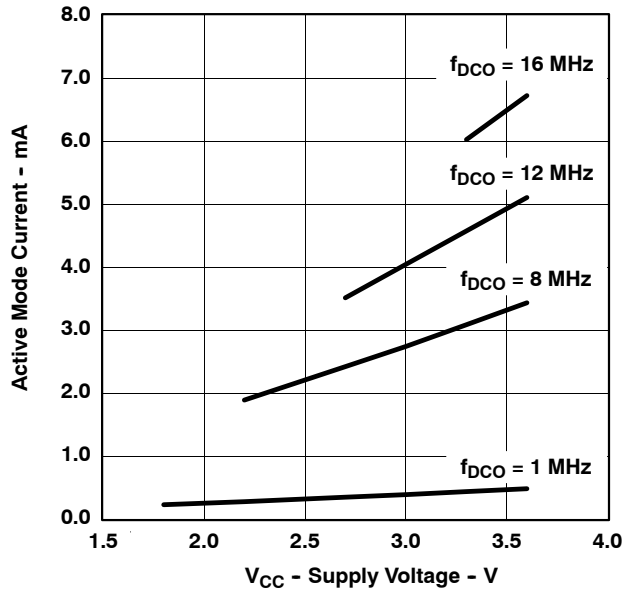

Figure 2. Active Mode Current vs V<sub>CC</sub>, T<sub>A</sub> = 25°C

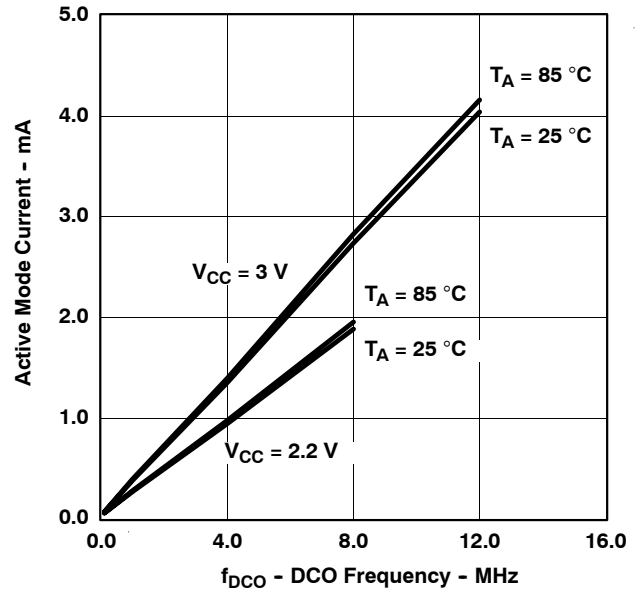

Figure 3. Active Mode Current vs DCO Frequency

# MSP430x22x2, MSP430x22x4 MIXED SIGNAL MICROCONTROLLER

SLAS504D - JULY 2006 - REVISED MARCH 2010

**electrical characteristics over recommended ranges of supply voltage and operating free-air temperature (unless otherwise noted) (continued)**

**low power mode supply currents (into DV<sub>CC</sub> + AV<sub>CC</sub>) excluding external current (see Notes 1 and 2)**

PARAMETER	TEST CONDITIONS	T <sub>A</sub>	V <sub>CC</sub>	MIN	TYP	MAX	UNIT	
I <sub>LPM0, 1MHz</sub> Low-power mode 0 (LPM0) current, see Note 3	f <sub>MCLK</sub> = 0 MHz, f <sub>SMCLK</sub> = f <sub>DCO</sub> = 1 MHz, f <sub>ACLK</sub> = 32,768 Hz, BCSCTL1 = CALBC1_1MHZ, DCOCTL = CALDCO_1MHZ, CPUOFF = 1, SCG0 = 0, SCG1 = 0, OSCOFF = 0		2.2 V		75	90	μA	
			3 V		90	120		
I <sub>LPM0, 100kHz</sub> Low-power mode 0 (LPM0) current, see Note 3	f <sub>MCLK</sub> = 0 MHz, f <sub>SMCLK</sub> = f <sub>DCO(0, 0)</sub> ≈ 100 kHz, f <sub>ACLK</sub> = 0 Hz, RSELX = 0, DCOX = 0, CPUOFF = 1, SCG0 = 0, SCG1 = 0, OSCOFF = 1		2.2 V		37	48	μA	
			3 V		41	65		
I <sub>LPM2</sub> Low-power mode 2 (LPM2) current, see Note 4	f <sub>MCLK</sub> = f <sub>SMCLK</sub> = 0 MHz, f <sub>DCO</sub> = 1 MHz, f <sub>ACLK</sub> = 32,768 Hz, BCSCTL1 = CALBC1_1MHZ, DCOCTL = CALDCO_1MHZ, CPUOFF = 1, SCG0 = 0, SCG1 = 1, OSCOFF = 0	-40-85°C	2.2 V		22	29	μA	
				105°C		31		
		105°C	3 V		25	32		
					34			
I <sub>LPM3, LFXT1</sub> Low-power mode 3 (LPM3) current, see Note 4	f <sub>DCO</sub> = f <sub>MCLK</sub> = f <sub>SMCLK</sub> = 0 MHz, f <sub>ACLK</sub> = 32,768 Hz, CPUOFF = 1, SCG0 = 1, SCG1 = 1, OSCOFF = 0	-40°C	2.2 V		0.7	1.4	μA	
				25°C		0.7		1.4
				85°C		2.4		3.3
				105°C		5		10
		105°C	3 V		0.9	1.5		
				25°C		0.9		1.5
				85°C		2.6		3.8
					6	12		
I <sub>LPM3, VLO</sub> Low-power mode 3 current, (LPM3) see Note 4	f <sub>DCO</sub> = f <sub>MCLK</sub> = f <sub>SMCLK</sub> = 0 MHz, f <sub>ACLK</sub> from internal LF oscillator (VLO), CPUOFF = 1, SCG0 = 1, SCG1 = 1, OSCOFF = 0	-40°C	2.2 V		0.4	1.0	μA	
				25°C		0.5		1.0
				85°C		1.8		2.9
				105°C		4.5		9
		105°C	3 V		0.5	1.2		
				25°C		0.6		1.2
				85°C		2.1		3.3
					5.5	11		
I <sub>LPM4</sub> Low-power mode 4 (LPM4) current, see Note 5	f <sub>DCO</sub> = f <sub>MCLK</sub> = f <sub>SMCLK</sub> = 0 MHz, f <sub>ACLK</sub> = 0 Hz, CPUOFF = 1, SCG0 = 1, SCG1 = 1, OSCOFF = 1	-40°C	2.2 V/3 V		0.1	0.5	μA	
				25°C		0.1		0.5
				85°C		1.5		3.0
				105°C		4.5		9

- NOTES: 1. All inputs are tied to 0 V or V<sub>CC</sub>. Outputs do not source or sink any current.  
 2. The currents are characterized with a Micro Crystal CC4V-T1A SMD crystal with a load capacitance of 9 pF. The internal and external load capacitance is chosen to closely match the required 9 pF.  
 3. Current for brownout and WDT clocked by SMCLK included.  
 4. Current for brownout and WDT clocked by ACLK included.  
 5. Current for brownout included.



**electrical characteristics over recommended ranges of supply voltage and operating free-air temperature (unless otherwise noted) (continued)**

**Schmitt-trigger inputs - Ports P1, P2, P3, P4, and  $\overline{\text{RST}}/\text{NMI}$**

PARAMETER	TEST CONDITIONS	V <sub>CC</sub>	MIN	TYP	MAX	UNIT
V <sub>IT+</sub> Positive-going input threshold voltage			0.45		0.75	V <sub>CC</sub>
		2.2 V	1.00		1.65	V
		3 V	1.35		2.25	
V <sub>IT-</sub> Negative-going input threshold voltage			0.25		0.55	V <sub>CC</sub>
		2.2 V	0.55		1.20	V
		3 V	0.75		1.65	
V <sub>hys</sub> Input voltage hysteresis (V <sub>IT+</sub> - V <sub>IT-</sub> )		2.2 V	0.2		1.0	V
		3 V	0.3		1.0	
R <sub>Pull</sub> Pullup/pulldown resistor	For pullup: V <sub>IN</sub> = V <sub>SS</sub> ; For pulldown: V <sub>IN</sub> = V <sub>CC</sub>		20	35	50	kΩ
C <sub>I</sub> Input capacitance	V <sub>IN</sub> = V <sub>SS</sub> or V <sub>CC</sub>			5		pF

**inputs - Ports P1 and P2**

PARAMETER	TEST CONDITIONS	V <sub>CC</sub>	MIN	MAX	UNIT
t <sub>(int)</sub> External interrupt timing	Port P1, P2: P1.x to P2.x, External trigger pulse width to set interrupt flag (see Note 1)	2.2 V/3 V	20		ns

NOTES: 1. An external signal sets the interrupt flag every time the minimum interrupt puls width t<sub>(int)</sub> is met. It may be set even with trigger signals shorter than t<sub>(int)</sub>.

**leakage current - Ports P1, P2, P3 and P4**

PARAMETER	TEST CONDITIONS	V <sub>CC</sub>	MIN	MAX	UNIT
I <sub>lkg(Px.x)</sub> High-impedance leakage current	See Notes 1 and 2	2.2 V/3 V		±50	nA

NOTES: 1. The leakage current is measured with V<sub>SS</sub> or V<sub>CC</sub> applied to the corresponding pin(s), unless otherwise noted.  
2. The leakage of the digital port pins is measured individually. The port pin is selected for input and the pullup/pulldown resistor is disabled.

# MSP430x22x2, MSP430x22x4 MIXED SIGNAL MICROCONTROLLER

SLAS504D - JULY 2006 - REVISED MARCH 2010

**electrical characteristics over recommended ranges of supply voltage and operating free-air temperature (unless otherwise noted) (continued)**

## outputs - Ports P1, P2, P3 and P4

PARAMETER	TEST CONDITIONS	V <sub>CC</sub>	MIN	MAX	UNIT
V <sub>OH</sub> High-level output voltage	I <sub>(OHmax)</sub> = -1.5 mA (see Note 1)	2.2 V	V <sub>CC</sub> -0.25	V <sub>CC</sub>	V
	I <sub>(OHmax)</sub> = -6 mA (see Note 2)	2.2 V	V <sub>CC</sub> -0.6	V <sub>CC</sub>	
	I <sub>(OHmax)</sub> = -1.5 mA (see Note 1)	3 V	V <sub>CC</sub> -0.25	V <sub>CC</sub>	
	I <sub>(OHmax)</sub> = -6 mA (see Note 2)	3 V	V <sub>CC</sub> -0.6	V <sub>CC</sub>	
V <sub>OL</sub> Low-level output voltage	I <sub>(OLmax)</sub> = 1.5 mA (see Note 1)	2.2 V	V <sub>SS</sub>	V <sub>SS</sub> +0.25	V
	I <sub>(OLmax)</sub> = 6 mA (see Note 2)	2.2 V	V <sub>SS</sub>	V <sub>SS</sub> +0.6	
	I <sub>(OLmax)</sub> = 1.5 mA (see Note 1)	3 V	V <sub>SS</sub>	V <sub>SS</sub> +0.25	
	I <sub>(OLmax)</sub> = 6 mA (see Note 2)	3 V	V <sub>SS</sub>	V <sub>SS</sub> +0.6	

- NOTES: 1. The maximum total current, I<sub>OHmax</sub> and I<sub>OLmax</sub>, for all outputs combined, should not exceed ±12 mA to hold the maximum voltage drop specified.  
 2. The maximum total current, I<sub>OHmax</sub> and I<sub>OLmax</sub>, for all outputs combined, should not exceed ±48 mA to hold the maximum voltage drop specified.

## output frequency - Ports P1, P2, P3 and P4

PARAMETER	TEST CONDITIONS	V <sub>CC</sub>	MIN	MAX	UNIT
f <sub>Px.y</sub> Port output frequency (with load)	P1.4/SMCLK, C <sub>L</sub> = 20 pF, R <sub>L</sub> = 1 kΩ against V <sub>CC</sub> /2 (see Notes 1 and 2)	2.2 V		10	MHz
		3 V		12	
f <sub>Port_CLK</sub> Clock output frequency	P2.0/ACLK, P1.4/SMCLK, C <sub>L</sub> = 20 pF (see Note 2)	2.2 V		12	MHz
		3 V		16	

- NOTES: 1. Alternatively a resistive divider with 2 times 2 kΩ between V<sub>CC</sub> and V<sub>SS</sub> is used as load. The output is connected to the center tap of the divider.  
 2. The output voltage reaches at least 10% and 90% V<sub>CC</sub> at the specified toggle frequency.



electrical characteristics over recommended ranges of supply voltage and operating free-air temperature (unless otherwise noted) (continued)

typical characteristics - outputs

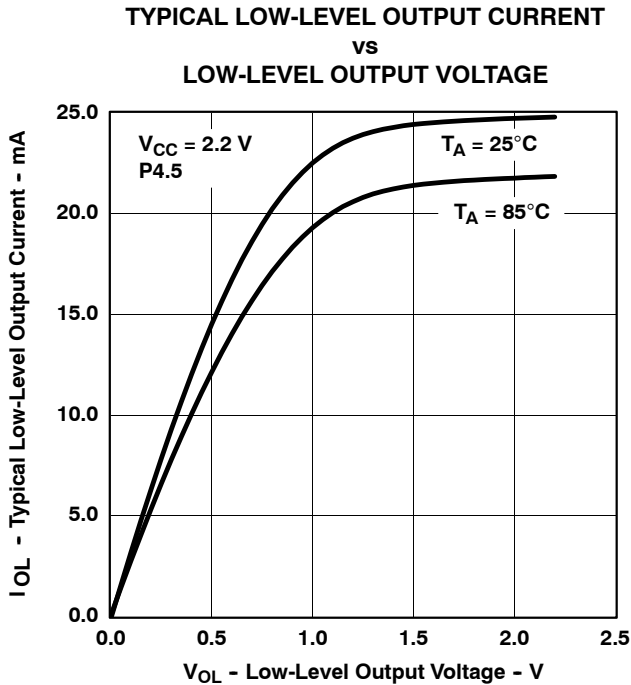

Figure 4

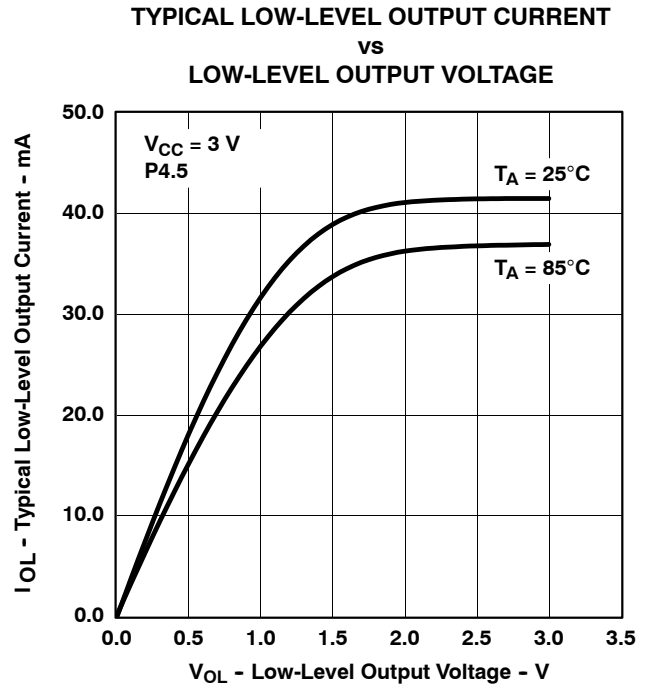

Figure 5

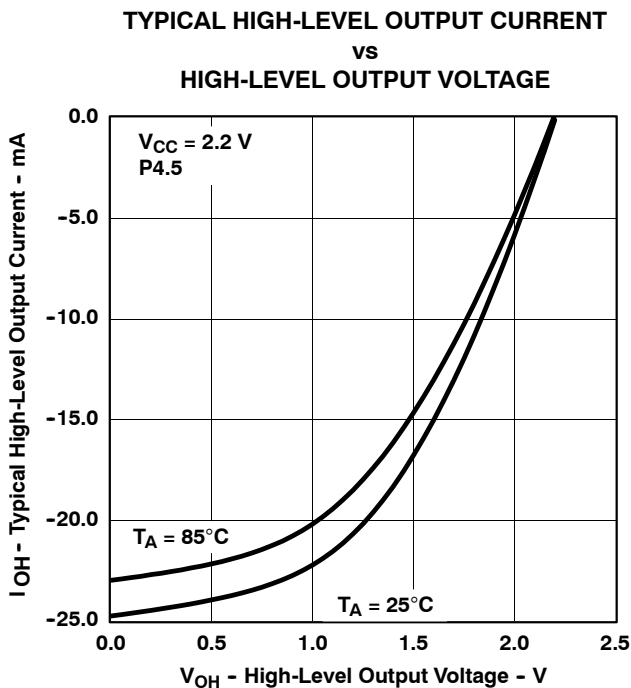

Figure 6

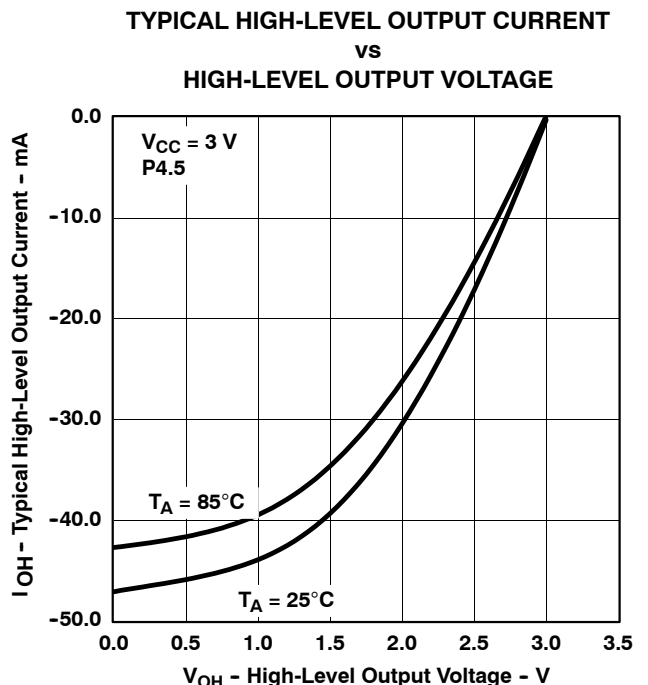

Figure 7

NOTE: One output loaded at a time

# MSP430x22x2, MSP430x22x4 MIXED SIGNAL MICROCONTROLLER

SLAS504D - JULY 2006 - REVISED MARCH 2010

electrical characteristics over recommended ranges of supply voltage and operating free-air temperature (unless otherwise noted) (continued)

## POR/brownout reset (BOR) (see Notes 1 and 2)

PARAMETER	TEST CONDITIONS	V <sub>CC</sub>	MIN	TYP	MAX	UNIT
V <sub>CC(start)</sub>	See Figure 8	dV <sub>CC</sub> /dt ≤ 3 V/s		0.7 × V <sub>(B_IT-)</sub>		V
V <sub>(B_IT-)</sub>	See Figure 8 through Figure 10	dV <sub>CC</sub> /dt ≤ 3 V/s			1.71	V
V <sub>hys(B_IT-)</sub>	See Figure 8	dV <sub>CC</sub> /dt ≤ 3 V/s	70	130	210	mV
t <sub>d(BOR)</sub>	See Figure 8				2000	μs
t <sub>(reset)</sub>	Pulse length needed at $\overline{\text{RST}}/\text{NMI}$ pin to accepted reset internally	2.2 V/3 V	2			μs

- NOTES: 1. The current consumption of the brownout module is already included in the I<sub>CC</sub> current consumption data. The voltage level V<sub>(B\_IT-)</sub> + V<sub>hys(B\_IT-)</sub> is ≤ 1.8V.  
 2. During power up, the CPU begins code execution following a period of t<sub>d(BOR)</sub> after V<sub>CC</sub> = V<sub>(B\_IT-)</sub> + V<sub>hys(B\_IT-)</sub>. The default DCO settings must not be changed until V<sub>CC</sub> ≥ V<sub>CC(min)</sub>, where V<sub>CC(min)</sub> is the minimum supply voltage for the desired operating frequency.

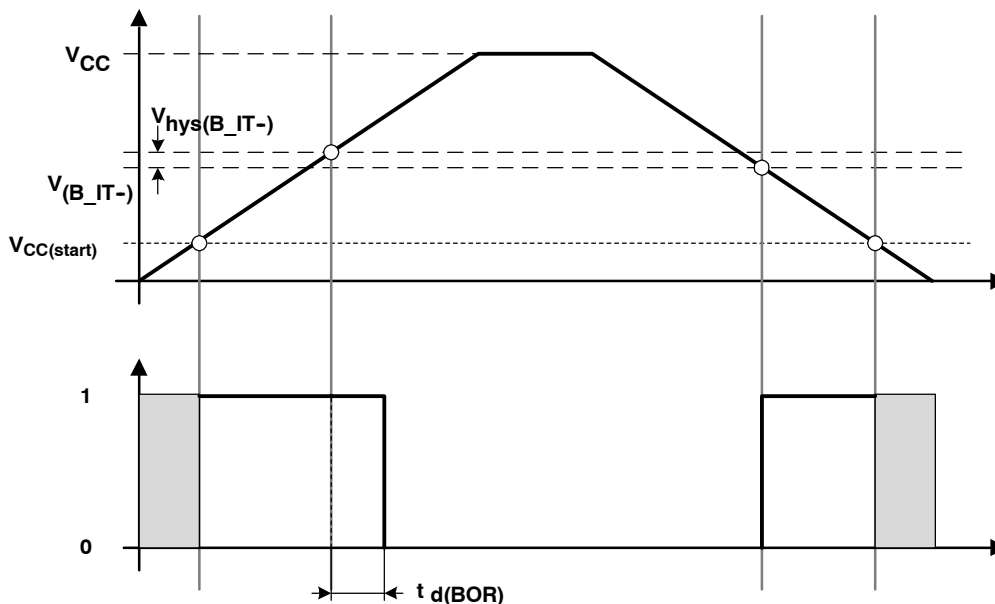

Figure 8. POR/Brownout Reset (BOR) vs Supply Voltage

electrical characteristics over recommended ranges of supply voltage and operating free-air temperature (unless otherwise noted) (continued)

typical characteristics - POR/brownout reset (BOR)

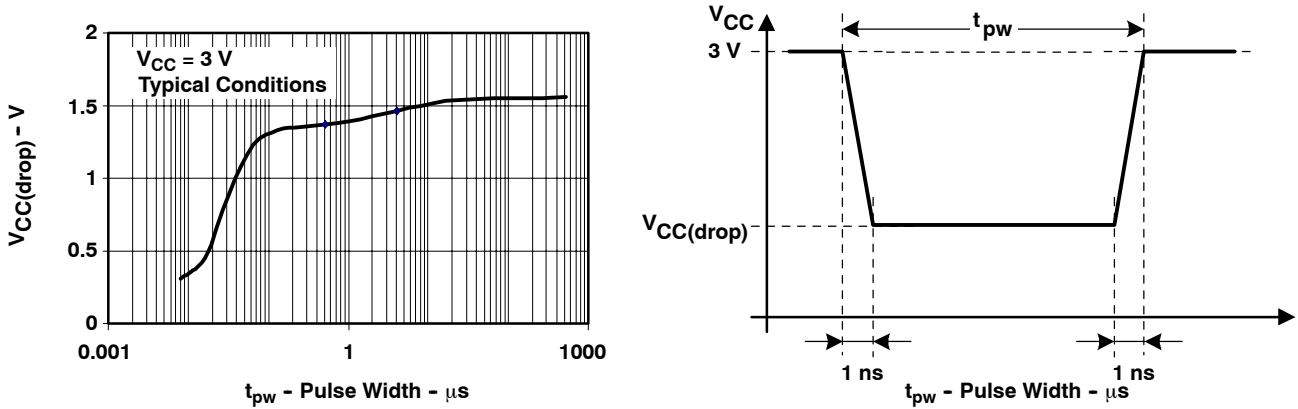

Figure 9.  $V_{CC(drop)}$  Level With a Square Voltage Drop to Generate a POR/Brownout Signal

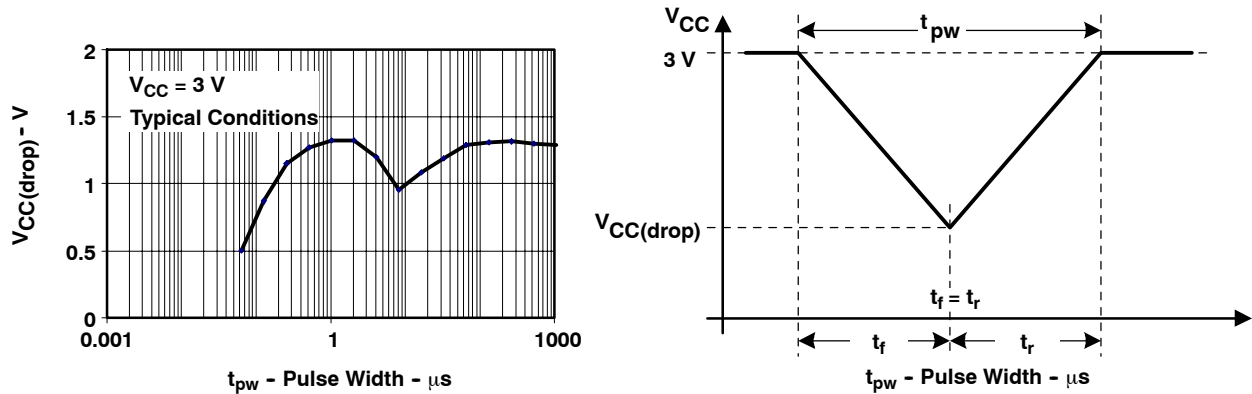

Figure 10.  $V_{CC(drop)}$  Level With a Triangle Voltage Drop to Generate a POR/Brownout Signal

# MSP430x22x2, MSP430x22x4 MIXED SIGNAL MICROCONTROLLER

SLAS504D - JULY 2006 - REVISED MARCH 2010

## electrical characteristics over recommended ranges of supply voltage and operating free-air temperature (unless otherwise noted) (continued)

### main DCO characteristics

- All ranges selected by RSELx overlap with RSELx + 1: RSELx = 0 overlaps RSELx = 1, ... RSELx = 14 overlaps RSELx = 15.
- DCO control bits DCOx have a step size as defined by parameter S<sub>DCO</sub>.
- Modulation control bits MODx select how often f<sub>DCO(RSEL,DCO+1)</sub> is used within the period of 32 DCOCLK cycles. The frequency f<sub>DCO(RSEL,DCO)</sub> is used for the remaining cycles. The frequency is an average equal to:

$$f_{\text{average}} = \frac{32 \times f_{\text{DCO(RSEL,DCO)}} \times f_{\text{DCO(RSEL,DCO+1)}}}{\text{MOD} \times f_{\text{DCO(RSEL,DCO)}} + (32 - \text{MOD}) \times f_{\text{DCO(RSEL,DCO+1)}}}$$

### DCO frequency

PARAMETER	TEST CONDITIONS	V <sub>CC</sub>	MIN	TYP	MAX	UNIT	
V <sub>CC</sub> Supply voltage range	RSELx < 14		1.8		3.6	V	
	RSELx = 14		2.2		3.6		
	RSELx = 15		3.0		3.6		
f <sub>DCO(0,0)</sub>	DCO frequency (0, 0)	RSELx = 0, DCOx = 0, MODx = 0	2.2 V/3 V	0.06	0.14	MHz	
f <sub>DCO(0,3)</sub>	DCO frequency (0, 3)	RSELx = 0, DCOx = 3, MODx = 0	2.2 V/3 V	0.07	0.17	MHz	
f <sub>DCO(1,3)</sub>	DCO frequency (1, 3)	RSELx = 1, DCOx = 3, MODx = 0	2.2 V/3 V	0.10	0.20	MHz	
f <sub>DCO(2,3)</sub>	DCO frequency (2, 3)	RSELx = 2, DCOx = 3, MODx = 0	2.2 V/3 V	0.14	0.28	MHz	
f <sub>DCO(3,3)</sub>	DCO frequency (3, 3)	RSELx = 3, DCOx = 3, MODx = 0	2.2 V/3 V	0.20	0.40	MHz	
f <sub>DCO(4,3)</sub>	DCO frequency (4, 3)	RSELx = 4, DCOx = 3, MODx = 0	2.2 V/3 V	0.28	0.54	MHz	
f <sub>DCO(5,3)</sub>	DCO frequency (5, 3)	RSELx = 5, DCOx = 3, MODx = 0	2.2 V/3 V	0.39	0.77	MHz	
f <sub>DCO(6,3)</sub>	DCO frequency (6, 3)	RSELx = 6, DCOx = 3, MODx = 0	2.2 V/3 V	0.54	1.06	MHz	
f <sub>DCO(7,3)</sub>	DCO frequency (7, 3)	RSELx = 7, DCOx = 3, MODx = 0	2.2 V/3 V	0.80	1.50	MHz	
f <sub>DCO(8,3)</sub>	DCO frequency (8, 3)	RSELx = 8, DCOx = 3, MODx = 0	2.2 V/3 V	1.10	2.10	MHz	
f <sub>DCO(9,3)</sub>	DCO frequency (9, 3)	RSELx = 9, DCOx = 3, MODx = 0	2.2 V/3 V	1.60	3.00	MHz	
f <sub>DCO(10,3)</sub>	DCO frequency (10, 3)	RSELx = 10, DCOx = 3, MODx = 0	2.2 V/3 V	2.50	4.30	MHz	
f <sub>DCO(11,3)</sub>	DCO frequency (11, 3)	RSELx = 11, DCOx = 3, MODx = 0	2.2 V/3 V	3.00	5.50	MHz	
f <sub>DCO(12,3)</sub>	DCO frequency (12, 3)	RSELx = 12, DCOx = 3, MODx = 0	2.2 V/3 V	4.30	7.30	MHz	
f <sub>DCO(13,3)</sub>	DCO frequency (13, 3)	RSELx = 13, DCOx = 3, MODx = 0	2.2 V/3 V	6.00	9.60	MHz	
f <sub>DCO(14,3)</sub>	DCO frequency (14, 3)	RSELx = 14, DCOx = 3, MODx = 0	2.2 V/3 V	8.60	13.9	MHz	
f <sub>DCO(15,3)</sub>	DCO frequency (15, 3)	RSELx = 15, DCOx = 3, MODx = 0	3 V	12.0	18.5	MHz	
f <sub>DCO(15,7)</sub>	DCO frequency (15, 7)	RSELx = 15, DCOx = 7, MODx = 0	3 V	16.0	26.0	MHz	
S <sub>RSEL</sub>	Frequency step between range RSEL and RSEL+1	S <sub>RSEL</sub> = f <sub>DCO(RSEL+1,DCO)</sub> /f <sub>DCO(RSEL,DCO)</sub>	2.2 V/3 V		1.55	ratio	
S <sub>DCO</sub>	Frequency step between tap DCO and DCO+1	S <sub>DCO</sub> = f <sub>DCO(RSEL,DCO+1)</sub> /f <sub>DCO(RSEL,DCO)</sub>	2.2 V/3 V	1.05	1.08	1.12	ratio
Duty Cycle	Measured at P1.4/SMCLK	2.2 V/3 V	40	50	60	%	





**electrical characteristics over recommended ranges of supply voltage and operating free-air temperature (unless otherwise noted) (continued)**

**calibrated DCO frequencies - tolerance at calibration**

PARAMETER		TEST CONDITIONS	T <sub>A</sub>	V <sub>CC</sub>	MIN	TYP	MAX	UNIT
Frequency tolerance at calibration			25°C	3 V	-1	±0.2	+1	%
f <sub>CAL(1MHz)</sub>	1-MHz calibration value	BCSCTL1= CALBC1_1MHZ, DCOCTL = CALDCO_1MHZ, Gating time: 5 ms	25°C	3 V	0.990	1	1.010	MHz
f <sub>CAL(8MHz)</sub>	8-MHz calibration value	BCSCTL1= CALBC1_8MHZ, DCOCTL = CALDCO_8MHZ, Gating time: 5 ms	25°C	3 V	7.920	8	8.080	MHz
f <sub>CAL(12MHz)</sub>	12-MHz calibration value	BCSCTL1= CALBC1_12MHZ, DCOCTL = CALDCO_12MHZ, Gating time: 5 ms	25°C	3 V	11.88	12	12.12	MHz
f <sub>CAL(16MHz)</sub>	16-MHz calibration value	BCSCTL1= CALBC1_16MHZ, DCOCTL = CALDCO_16MHZ, Gating time: 2 ms	25°C	3 V	15.84	16	16.16	MHz

**calibrated DCO frequencies - tolerance over temperature 0°C to +85°C**

PARAMETER		TEST CONDITIONS	T <sub>A</sub>	V <sub>CC</sub>	MIN	TYP	MAX	UNIT
1-MHz tolerance over temperature			0-85°C	3.0 V	-2.5	±0.5	+2.5	%
8-MHz tolerance over temperature			0-85°C	3.0 V	-2.5	±1.0	+2.5	%
12-MHz tolerance over temperature			0-85°C	3.0 V	-2.5	±1.0	+2.5	%
16-MHz tolerance over temperature			0-85°C	3.0 V	-3.0	±2.0	+3.0	%
f <sub>CAL(1MHz)</sub>	1-MHz calibration value	BCSCTL1= CALBC1_1MHZ, DCOCTL = CALDCO_1MHZ, Gating time: 5 ms	0-85°C	2.2 V	0.970	1	1.030	MHz
				3.0 V	0.975	1	1.025	
				3.6 V	0.970	1	1.030	
f <sub>CAL(8MHz)</sub>	8-MHz calibration value	BCSCTL1= CALBC1_8MHZ, DCOCTL = CALDCO_8MHZ, Gating time: 5 ms	0-85°C	2.2 V	7.760	8	8.400	MHz
				3.0 V	7.800	8	8.200	
				3.6 V	7.600	8	8.240	
f <sub>CAL(12MHz)</sub>	12-MHz calibration value	BCSCTL1= CALBC1_12MHZ, DCOCTL = CALDCO_12MHZ, Gating time: 5 ms	0-85°C	2.2 V	11.70	12	12.30	MHz
				3.0 V	11.70	12	12.30	
				3.6 V	11.70	12	12.30	
f <sub>CAL(16MHz)</sub>	16-MHz calibration value	BCSCTL1= CALBC1_16MHZ, DCOCTL = CALDCO_16MHZ, Gating time: 2 ms	0-85°C	3.0 V	15.52	16	16.48	MHz
				3.6 V	15.00	16	16.48	

# MSP430x22x2, MSP430x22x4 MIXED SIGNAL MICROCONTROLLER

SLAS504D - JULY 2006 - REVISED MARCH 2010

**electrical characteristics over recommended ranges of supply voltage and operating free-air temperature (unless otherwise noted) (continued)**

## calibrated DCO frequencies - tolerance over supply voltage $V_{CC}$

PARAMETER	TEST CONDITIONS	$T_A$	$V_{CC}$	MIN	TYP	MAX	UNIT
1-MHz tolerance over $V_{CC}$		25°C	1.8 V - 3.6 V	-3	±2	+3	%
8-MHz tolerance over $V_{CC}$		25°C	1.8 V - 3.6 V	-3	±2	+3	%
12-MHz tolerance over $V_{CC}$		25°C	2.2 V - 3.6 V	-3	±2	+3	%
16-MHz tolerance over $V_{CC}$		25°C	3.0 V - 3.6 V	-6	±2	+3	%
$f_{CAL(1MHz)}$ 1-MHz calibration value	BCSCTL1= CALBC1_1MHZ, DCOCTL = CALDCO_1MHZ, Gating time: 5 ms	25°C	1.8 V - 3.6 V	0.970	1	1.030	MHz
$f_{CAL(8MHz)}$ 8-MHz calibration value	BCSCTL1= CALBC1_8MHZ, DCOCTL = CALDCO_8MHZ, Gating time: 5 ms	25°C	1.8 V - 3.6 V	7.760	8	8.240	MHz
$f_{CAL(12MHz)}$ 12-MHz calibration value	BCSCTL1= CALBC1_12MHZ, DCOCTL = CALDCO_12MHZ, Gating time: 5 ms	25°C	2.2 V - 3.6 V	11.64	12	12.36	MHz
$f_{CAL(16MHz)}$ 16-MHz calibration value	BCSCTL1= CALBC1_16MHZ, DCOCTL = CALDCO_16MHZ, Gating time: 2 ms	25°C	3.0 V - 3.6 V	15.00	16	16.48	MHz

## calibrated DCO frequencies - overall tolerance

PARAMETER	TEST CONDITIONS	$T_A$	$V_{CC}$	MIN	TYP	MAX	UNIT
1-MHz tolerance overall		I: -40-85°C T: -40-105°C	1.8 V to 3.6 V	-5	±2	+5	%
8-MHz tolerance overall		I: -40-85°C T: -40-105°C	1.8 V to 3.6 V	-5	±2	+5	%
12-MHz tolerance overall		I: -40-85°C T: -40-105°C	2.2 V to 3.6 V	-5	±2	+5	%
16-MHz tolerance overall		I: -40-85°C T: -40-105°C	3.0 V to 3.6 V	-6	±3	+6	%
$f_{CAL(1MHz)}$ 1-MHz calibration value	BCSCTL1= CALBC1_1MHZ, DCOCTL = CALDCO_1MHZ, Gating time: 5 ms	I: -40-85°C T: -40-105°C	1.8 V to 3.6 V	0.950	1	1.050	MHz
$f_{CAL(8MHz)}$ 8-MHz calibration value	BCSCTL1= CALBC1_8MHZ, DCOCTL = CALDCO_8MHZ, Gating time: 5 ms	I: -40-85°C T: -40-105°C	1.8 V to 3.6 V	7.600	8	8.400	MHz
$f_{CAL(12MHz)}$ 12-MHz calibration value	BCSCTL1= CALBC1_12MHZ, DCOCTL = CALDCO_12MHZ, Gating time: 5 ms	I: -40-85°C T: -40-105°C	2.2 V to 3.6 V	11.40	12	12.60	MHz
$f_{CAL(16MHz)}$ 16-MHz calibration value	BCSCTL1= CALBC1_16MHZ, DCOCTL = CALDCO_16MHZ, Gating time: 2 ms	I: -40-85°C T: -40-105°C	3.0 V to 3.6 V	15.00	16	17.00	MHz



typical characteristics - calibrated 1-MHz DCO frequency

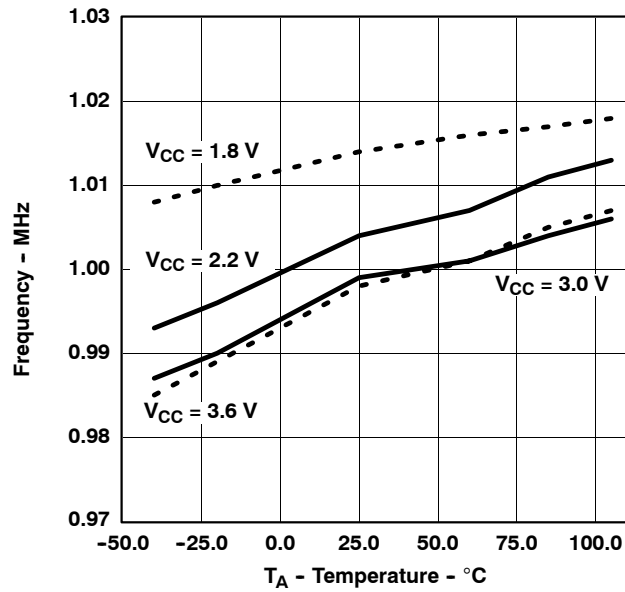

Figure 11. Calibrated 1-MHz Frequency vs Temperature

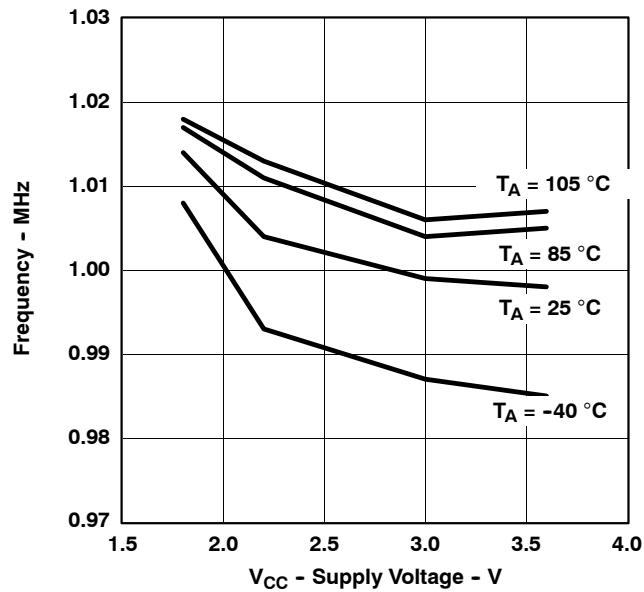

Figure 12. Calibrated 1-MHz Frequency vs V<sub>CC</sub>

# MSP430x22x2, MSP430x22x4 MIXED SIGNAL MICROCONTROLLER

SLAS504D - JULY 2006 - REVISED MARCH 2010

electrical characteristics over recommended ranges of supply voltage and operating free-air temperature (unless otherwise noted) (continued)

## wake-up from lower power modes (LPM3/4)

PARAMETER	TEST CONDITIONS	V <sub>CC</sub>	MIN	TYP	MAX	UNIT
t <sub>DCO,LPM3/4</sub> DCO clock wake-up time from LPM3/4 (see Note 1)	BCSCTL1= CALBC1_1MHZ, DCOCTL = CALDCO_1MHZ	2.2 V/3 V			2	μs
	BCSCTL1= CALBC1_8MHZ, DCOCTL = CALDCO_8MHZ	2.2 V/3 V			1.5	
	BCSCTL1= CALBC1_12MHZ, DCOCTL = CALDCO_12MHZ	2.2 V/3 V			1	
	BCSCTL1= CALBC1_16MHZ, DCOCTL = CALDCO_16MHZ	3 V			1	
t <sub>CPU,LPM3/4</sub> CPU wake-up time from LPM3/4 (see Note 2)				1/f <sub>MCLK</sub> + t <sub>Clock,LPM3/4</sub>		

NOTES: 1. The DCO clock wake-up time is measured from the edge of an external wake-up signal (e.g., port interrupt) to the first clock edge observable externally on a clock pin (MCLK or SMCLK).  
2. Parameter applicable only if DCOCLK is used for MCLK.

## typical characteristics - DCO clock wake-up time from LPM3/4

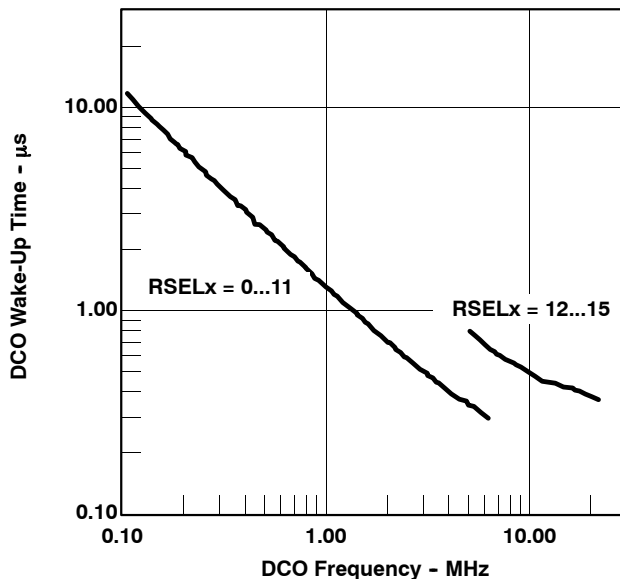

Figure 13. Clock Wake-Up Time From LPM3 vs DCO Frequency

electrical characteristics over recommended ranges of supply voltage and operating free-air temperature (unless otherwise noted) (continued)

DCO with external resistor  $R_{OSC}$  (see Note 1)

PARAMETER	TEST CONDITIONS	$V_{CC}$	MIN	TYP	MAX	UNIT
$f_{DCO,ROSC}$ DCO output frequency with $R_{OSC}$	DCOR = 1, RSELx = 4, DCOx = 3, MODx = 0, $T_A = 25^\circ\text{C}$	2.2 V		1.8		MHz
		3 V		1.95		
$D_t$ Temperature drift	DCOR = 1, RSELx = 4, DCOx = 3, MODx = 0	2.2 V/3 V		$\pm 0.1$		$\%/\text{C}$
$D_V$ Drift with $V_{CC}$	DCOR = 1, RSELx = 4, DCOx = 3, MODx = 0	2.2 V/3 V		10		$\%/V$

NOTES: 1.  $R_{OSC} = 100\text{k}\Omega$ . Metal film resistor, type 0257. 0.6 watt with 1% tolerance and  $T_K = \pm 50\text{ppm}/\text{C}$ .

typical characteristics - DCO with external resistor  $R_{OSC}$

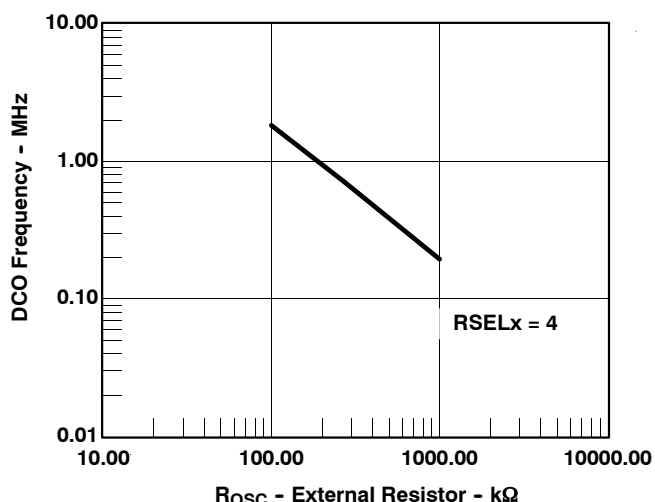

Figure 14. DCO Frequency vs  $R_{OSC}$ ,  $V_{CC} = 2.2\text{ V}$ ,  $T_A = 25^\circ\text{C}$

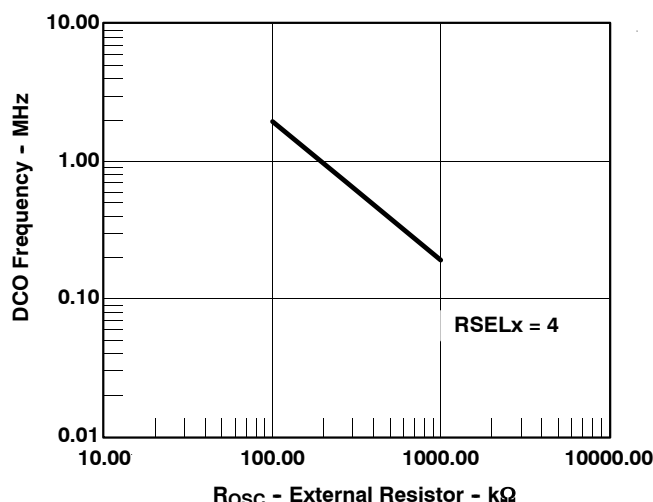

Figure 15. DCO Frequency vs  $R_{OSC}$ ,  $V_{CC} = 3.0\text{ V}$ ,  $T_A = 25^\circ\text{C}$

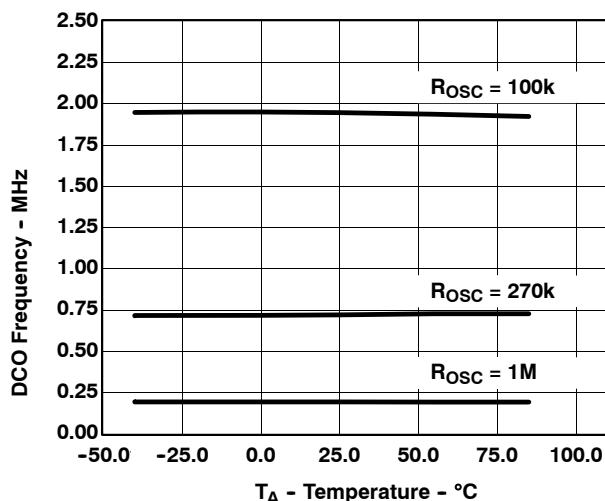

Figure 16. DCO Frequency vs Temperature,  $V_{CC} = 3.0\text{ V}$

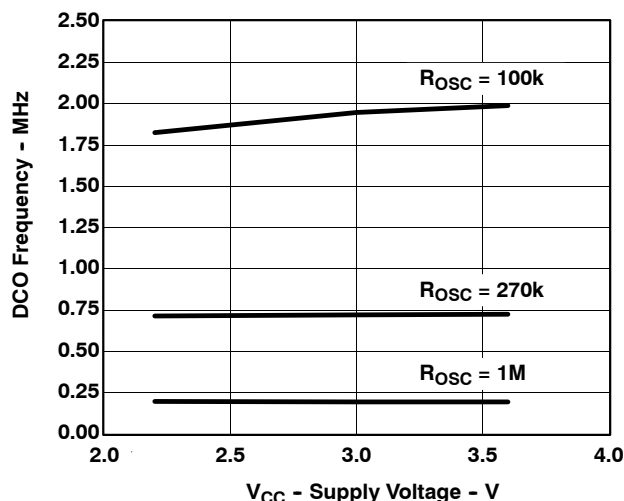

Figure 17. DCO Frequency vs  $V_{CC}$ ,  $T_A = 25^\circ\text{C}$

# MSP430x22x2, MSP430x22x4 MIXED SIGNAL MICROCONTROLLER

SLAS504D - JULY 2006 - REVISED MARCH 2010

**electrical characteristics over recommended ranges of supply voltage and operating free-air temperature (unless otherwise noted) (continued)**

## crystal oscillator, LFXT1, low frequency modes (see Note 4)

PARAMETER		TEST CONDITIONS	V <sub>CC</sub>	MIN	TYP	MAX	UNIT
f <sub>LFXT1,LF</sub>	LFXT1 oscillator crystal frequency, LF mode 0, 1	XTS = 0, LFXT1Sx = 0 or 1	1.8 V to 3.6 V		32,768		Hz
f <sub>LFXT1,LF,logic</sub>	LFXT1 oscillator logic level square wave input frequency, LF mode	XTS = 0, LFXT1Sx = 3	1.8 V to 3.6 V	10,000	32,768	50,000	Hz
O <sub>ALF</sub>	Oscillation allowance for LF crystals	XTS = 0, LFXT1Sx = 0; f <sub>LFXT1,LF</sub> = 32,768 kHz, C <sub>L,eff</sub> = 6 pF			500		kΩ
		XTS = 0, LFXT1Sx = 0; f <sub>LFXT1,LF</sub> = 32,768 kHz, C <sub>L,eff</sub> = 12 pF			200		
C <sub>L,eff</sub>	Integrated effective load capacitance, LF mode (see Note 1)	XTS = 0, XCAPx = 0			1		pF
		XTS = 0, XCAPx = 1			5.5		
		XTS = 0, XCAPx = 2			8.5		
		XTS = 0, XCAPx = 3			11		
Duty Cycle	LF mode	XTS = 0, Measured at P1.4/ACLK, f <sub>LFXT1,LF</sub> = 32,768 Hz	2.2 V/3 V	30	50	70	%
f <sub>Fault,LF</sub>	Oscillator fault frequency, LF mode (see Note 3)	XTS = 0, LFXT1Sx = 3 (see Note 2)	2.2 V/3 V	10		10,000	Hz

- NOTES: 1. Includes parasitic bond and package capacitance (approximately 2pF per pin).  
 Since the PCB adds additional capacitance it is recommended to verify the correct load by measuring the ACLK frequency. For a correct setup the effective load capacitance should always match the specification of the used crystal.
2. Measured with logic level input frequency but also applies to operation with crystals.
3. Frequencies below the MIN specification set the fault flag, frequencies above the MAX specification do not set the fault flag. Frequencies in between might set the flag.
4. To improve EMI on the LFXT1 oscillator the following guidelines should be observed.
- Keep as short a trace as possible between the device and the crystal.
  - Design a good ground plane around the oscillator pins.
  - Prevent crosstalk from other clock or data lines into oscillator pins XIN and XOUT.
  - Avoid running PCB traces underneath or adjacent to the XIN and XOUT pins.
  - Use assembly materials and praxis to avoid any parasitic load on the oscillator XIN and XOUT pins.
  - If conformal coating is used, ensure that it does not induce capacitive/resistive leakage between the oscillator pins.
  - Do not route the XOUT line to the JTAG header to support the serial programming adapter as shown in other documentation. This signal is no longer required for the serial programming adapter.

## internal very low power, low frequency oscillator (VLO)

PARAMETER	TEST CONDITIONS	T <sub>A</sub>	V <sub>CC</sub>	MIN	TYP	MAX	UNIT
f <sub>VLO</sub>	VLO frequency	-40-85°C	2.2 V/3 V	4	12	20	kHz
		105°C	2.2 V/3 V			22	
df <sub>VLO</sub> /dT	(see Note 1)	I: -40-85°C T: -40-105°C	2.2 V/3 V		0.5		%/°C
df <sub>VLO</sub> /dV <sub>CC</sub>	(see Note 2)	25°C	1.8V to 3.6V		4		%/V

- NOTES: 1. Calculated using the box method:  
 I version: (MAX(-40...85°C) - MIN(-40...85°C))/MIN(-40...85°C)/(85°C - (-40°C))  
 T version: (MAX(-40...105°C) - MIN(-40...105°C))/MIN(-40...105°C)/(105°C - (-40°C))
2. Calculated using the box method: (MAX(1.8...3.6 V) - MIN(1.8...3.6 V))/MIN(1.8...3.6 V)/(3.6 V - 1.8 V)



electrical characteristics over recommended ranges of supply voltage and operating free-air temperature (unless otherwise noted) (continued)

crystal oscillator, LFXT1, high frequency modes (see Note 5)

PARAMETER		TEST CONDITIONS	V <sub>CC</sub>	MIN	TYP	MAX	UNIT
f <sub>LFXT1,HF0</sub>	LFXT1 oscillator crystal frequency, HF mode 0	XTS = 1, LFXT1Sx = 0	1.8 V to 3.6 V	0.4		1	MHz
f <sub>LFXT1,HF1</sub>	LFXT1 oscillator crystal frequency, HF mode 1	XTS = 1, LFXT1Sx = 1	1.8 V to 3.6 V	1		4	MHz
f <sub>LFXT1,HF2</sub>	LFXT1 oscillator crystal frequency, HF mode 2	XTS = 1, LFXT1Sx = 2	1.8 V to 3.6 V	2		10	MHz
			2.2 V to 3.6 V	2		12	
			3.0 V to 3.6 V	2		16	
f <sub>LFXT1,HF,logic</sub>	LFXT1 oscillator logic level square-wave input frequency, HF mode	XTS = 1, LFXT1Sx = 3	1.8 V to 3.6 V	0.4		10	MHz
			2.2 V to 3.6 V	0.4		12	
			3.0 V to 3.6 V	0.4		16	
OA <sub>HF</sub>	Oscillation allowance for HF crystals (see Figure 18 and Figure 19)	XTS = 0, LFXT1Sx = 0, f <sub>LFXT1,HF</sub> = 1 MHz, C <sub>L,eff</sub> = 15 pF		2700		Ω	
		XTS = 0, LFXT1Sx = 1 f <sub>LFXT1,HF</sub> = 4 MHz, C <sub>L,eff</sub> = 15 pF		800			
		XTS = 0, LFXT1Sx = 2 f <sub>LFXT1,HF</sub> = 16 MHz, C <sub>L,eff</sub> = 15 pF		300			
C <sub>L,eff</sub>	Integrated effective load capacitance, HF mode (see Note 1)	XTS = 1 (see Note 2)		1		pF	
Duty Cycle	HF mode	XTS = 1, Measured at P1.4/ACLK, f <sub>LFXT1,HF</sub> = 10 MHz	2.2 V/3 V	40	50	60	%
		XTS = 1, Measured at P1.4/ACLK, f <sub>LFXT1,HF</sub> = 16 MHz	2.2 V/3 V	40	50	60	
f <sub>Fault,HF</sub>	Oscillator fault frequency, HF mode (see Note 4)	XTS = 1, LFXT1Sx = 3 (see Notes 3)	2.2 V/3 V	30		300	kHz

- NOTES: 1. Includes parasitic bond and package capacitance (approximately 2 pF per pin).  
Since the PCB adds additional capacitance it is recommended to verify the correct load by measuring the ACLK frequency. For a correct setup the effective load capacitance should always match the specification of the used crystal.
2. Requires external capacitors at both terminals. Values are specified by crystal manufacturers.
3. Measured with logic level input frequency but also applies to operation with crystals.
4. Frequencies below the MIN specification set the fault flag, frequencies above the MAX specification do not set the fault flag. Frequencies in between might set the flag.
5. To improve EMI on the LFXT1 oscillator the following guidelines should be observed.
- Keep the trace between the device and the crystal as short as possible.
  - Design a good ground plane around the oscillator pins.
  - Prevent crosstalk from other clock or data lines into oscillator pins XIN and XOUT.
  - Avoid running PCB traces underneath or adjacent to the XIN and XOUT pins.
  - Use assembly materials and praxis to avoid any parasitic load on the oscillator XIN and XOUT pins.
  - If conformal coating is used, ensure that it does not induce capacitive/resistive leakage between the oscillator pins.
  - Do not route the XOUT line to the JTAG header to support the serial programming adapter as shown in other documentation. This signal is no longer required for the serial programming adapter.

# MSP430x22x2, MSP430x22x4 MIXED SIGNAL MICROCONTROLLER

SLAS504D - JULY 2006 - REVISED MARCH 2010

electrical characteristics over recommended ranges of supply voltage and operating free-air temperature (unless otherwise noted) (continued)

typical characteristics - LFXT1 oscillator in HF mode (XTS = 1)

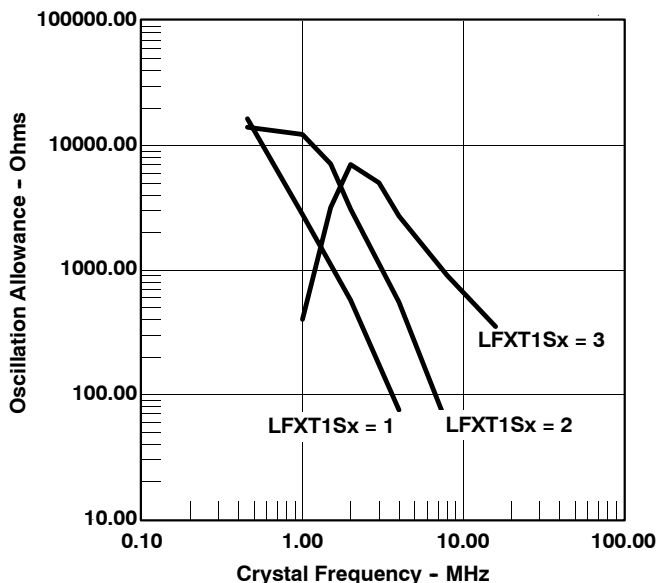

Figure 18. Oscillation Allowance vs Crystal Frequency,  $C_{L,eff} = 15 \text{ pF}$ ,  $T_A = 25^\circ\text{C}$

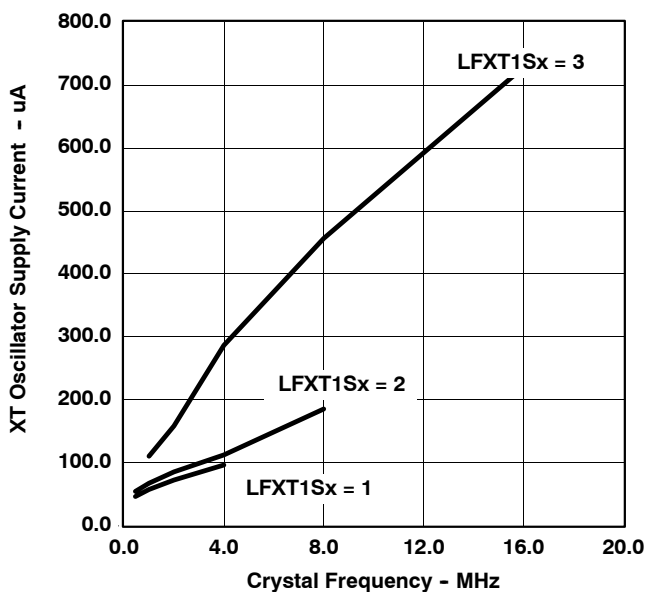

Figure 19. XT Oscillator Supply Current vs Crystal Frequency,  $C_{L,eff} = 15 \text{ pF}$ ,  $T_A = 25^\circ\text{C}$



**electrical characteristics over recommended ranges of supply voltage and operating free-air temperature (unless otherwise noted) (continued)**

**Timer\_A**

PARAMETER		TEST CONDITIONS	V <sub>CC</sub>	MIN	MAX	UNIT
f <sub>TA</sub>	Timer_A clock frequency	Internal: SMCLK, ACLK, External: TACLK, INCLK, Duty cycle = 50% ±10%	2.2 V		10	MHz
			3 V		16	
t <sub>TA,cap</sub>	Timer_A, capture timing	TA0, TA1, TA2	2.2 V/3 V	20		ns

**Timer\_B**

PARAMETER		TEST CONDITIONS	V <sub>CC</sub>	MIN	MAX	UNIT
f <sub>TB</sub>	Timer_B clock frequency	Internal: SMCLK, ACLK, External: TBCLK, Duty cycle = 50% ±10%	2.2 V		10	MHz
			3 V		16	
t <sub>TB,cap</sub>	Timer_B, capture timing	TB0, TB1, TB2	2.2 V/3 V	20		ns

# MSP430x22x2, MSP430x22x4 MIXED SIGNAL MICROCONTROLLER

SLAS504D - JULY 2006 - REVISED MARCH 2010

electrical characteristics over recommended ranges of supply voltage and operating free-air temperature (unless otherwise noted) (continued)

## USCI (UART mode)

PARAMETER	TEST CONDITIONS	V <sub>CC</sub>	MIN	TYP	MAX	UNIT
f <sub>USCI</sub>	USCI input clock frequency Internal: SMCLK, ACLK External: UCLK Duty cycle = 50% ± 10%			f <sub>SYSTEM</sub>		MHz
f <sub>BITCLK</sub>	BITCLK clock frequency (equals baud rate in MBaud)	2.2V /3 V			1	MHz
t <sub>τ</sub>	UART receive deglitch time (see Note 1)	2.2 V	50	150	600	ns
		3 V	50	100	600	ns

NOTES: 1. Pulses on the UART receive input (UCxRX) shorter than the UART receive deglitch time are suppressed. To ensure that pulses are correctly recognized, their width should exceed the maximum specification of the deglitch time.

## USCI (SPI master mode) (see Figure 20 and Figure 21)

PARAMETER	TEST CONDITIONS	V <sub>CC</sub>	MIN	MAX	UNIT
f <sub>USCI</sub>	USCI input clock frequency SMCLK, ACLK Duty cycle = 50% ± 10%			f <sub>SYSTEM</sub>	MHz
t <sub>SU,MI</sub>	SOMI input data setup time	2.2 V	110		ns
		3 V	75		
t <sub>HD,MI</sub>	SOMI input data hold time	2.2 V	0		ns
		3 V	0		
t <sub>VALID,MO</sub>	SIMO output data valid time C <sub>L</sub> = 20 pF	2.2 V		30	ns
		3 V		20	

NOTE:  $f_{UCxCLK} = \frac{1}{2t_{LO/HI}}$  with  $t_{LO/HI} \geq \max(t_{VALID,MO}(USCI) + t_{SU,SI}(Slave), t_{SU,MI}(USCI) + t_{VALID,SO}(Slave))$ .

For the slave's parameters t<sub>SU,SI(Slave)</sub> and t<sub>VALID,SO(Slave)</sub>, see the SPI parameters of the attached slave.

## USCI (SPI slave mode) (see Figure 22 and Figure 23)

PARAMETER	TEST CONDITIONS	V <sub>CC</sub>	MIN	TYP	MAX	UNIT
t <sub>STE,LEAD</sub>	STE lead time STE low to clock	2.2 V/3 V		50		ns
t <sub>STE,LAG</sub>	STE lag time Last clock to STE high	2.2 V/3 V	10			ns
t <sub>STE,ACC</sub>	STE access time STE low to SOMI data out	2.2 V/3 V		50		ns
t <sub>STE,DIS</sub>	STE disable time STE high to SOMI high impedance	2.2 V/3 V		50		ns
t <sub>SU,SI</sub>	SIMO input data setup time	2.2 V	20			ns
		3 V	15			
t <sub>HD,SI</sub>	SIMO input data hold time	2.2 V	10			ns
		3 V	10			
t <sub>VALID,SO</sub>	SOMI output data valid time C <sub>L</sub> = 20 pF	2.2 V		75	110	ns
		3 V		50	75	

NOTE:  $f_{UCxCLK} = \frac{1}{2t_{LO/HI}}$  with  $t_{LO/HI} \geq \max(t_{VALID,MO}(Master) + t_{SU,SI}(USCI), t_{SU,MI}(Master) + t_{VALID,SO}(USCI))$ .

For the master's parameters t<sub>SU,MI(Master)</sub> and t<sub>VALID,MO(Master)</sub>, see the SPI parameters of the attached master.



electrical characteristics over recommended ranges of supply voltage and operating free-air temperature (unless otherwise noted) (continued)

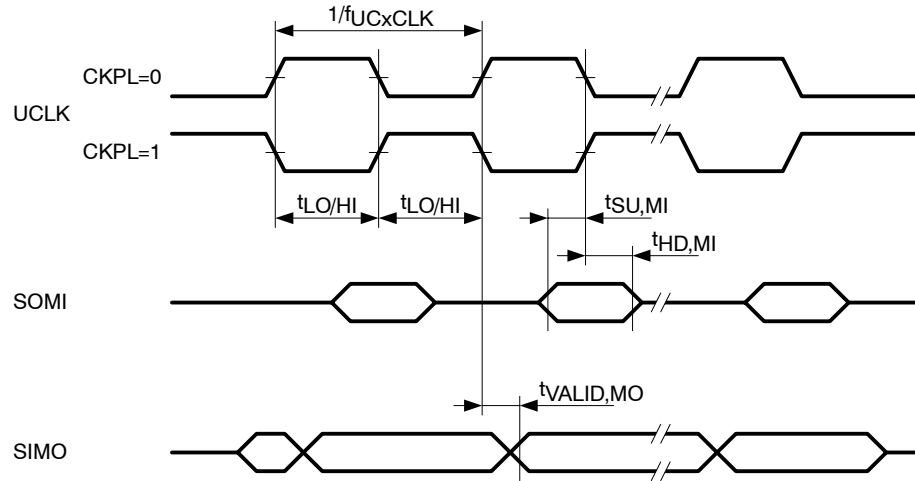

Figure 20. SPI Master Mode, CKPH = 0

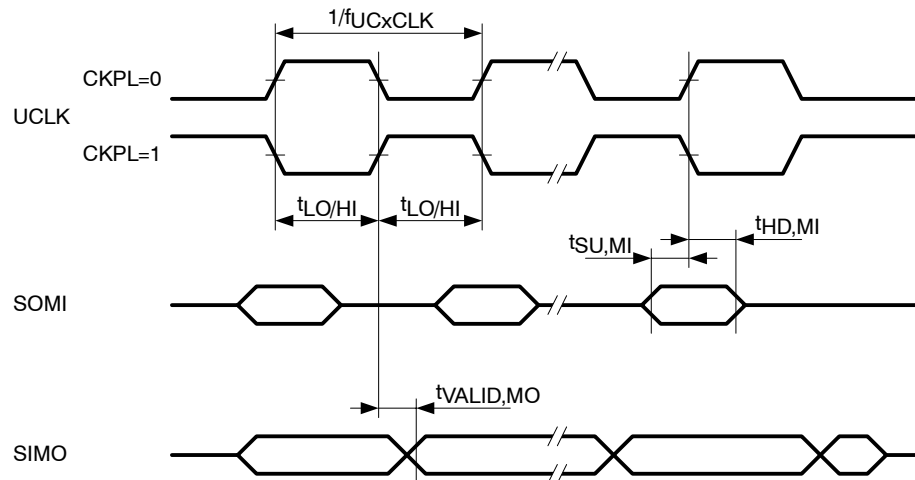

Figure 21. SPI Master Mode, CKPH = 1

# MSP430x22x2, MSP430x22x4 MIXED SIGNAL MICROCONTROLLER

SLAS504D - JULY 2006 - REVISED MARCH 2010

electrical characteristics over recommended ranges of supply voltage and operating free-air temperature (unless otherwise noted) (continued)

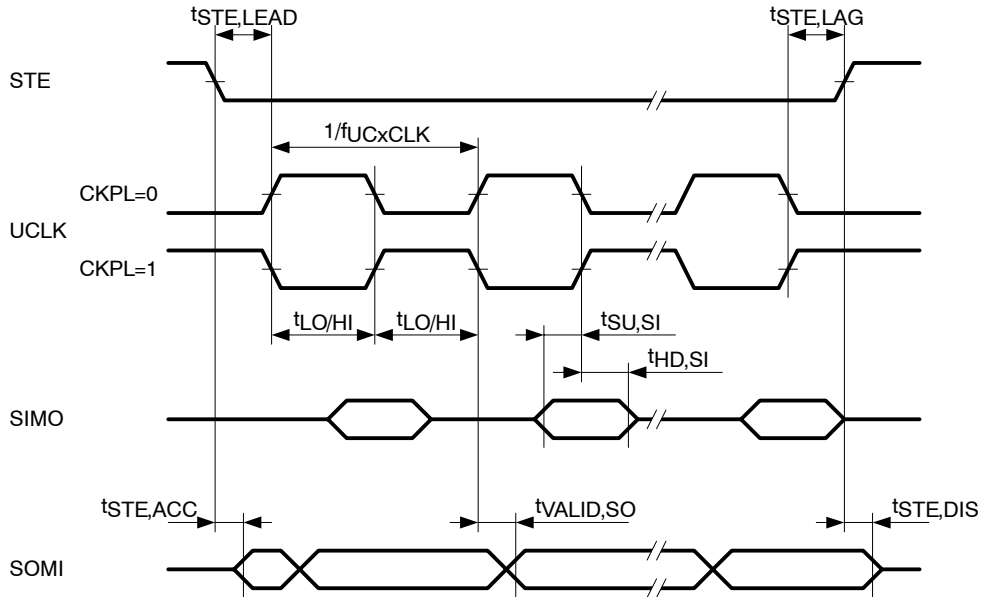

Figure 22. SPI Slave Mode, CKPH = 0

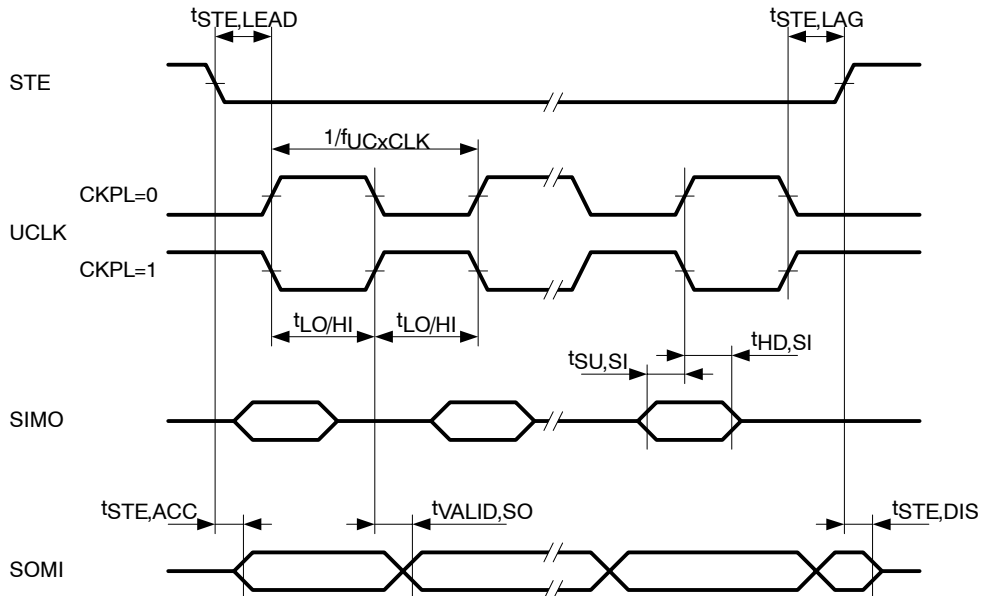

Figure 23. SPI Slave Mode, CKPH = 1

electrical characteristics over recommended ranges of supply voltage and operating free-air temperature (unless otherwise noted) (continued)

USCI (I2C mode) (see Figure 24)

PARAMETER	TEST CONDITIONS	V <sub>CC</sub>	MIN	TYP	MAX	UNIT	
f <sub>USCI</sub>	USCI input clock frequency	Internal: SMCLK, ACLK External: UCLK Duty cycle = 50% ± 10%		f <sub>SYSTEM</sub>		MHz	
f <sub>SCL</sub>	SCL clock frequency		0		400	kHz	
t <sub>HD,STA</sub>	Hold time (repeated) START	f <sub>SCL</sub> ≤ 100 kHz	2.2 V/3 V	4.0		μs	
		f <sub>SCL</sub> > 100 kHz	2.2 V/3 V	0.6			
t <sub>SU,STA</sub>	Setup time for a repeated START	f <sub>SCL</sub> ≤ 100 kHz	2.2 V/3 V	4.7		μs	
		f <sub>SCL</sub> > 100 kHz	2.2 V/3 V	0.6			
t <sub>HD,DAT</sub>	Data hold time		2.2 V/3 V	0		ns	
t <sub>SU,DAT</sub>	Data setup time		2.2 V/3 V	250		ns	
t <sub>SU,STO</sub>	Setup time for STOP		2.2 V/3 V	4.0		μs	
t <sub>SP</sub>	Pulse width of spikes suppressed by input filter	2.2 V		50	150	600	ns
		3 V		50	100	600	

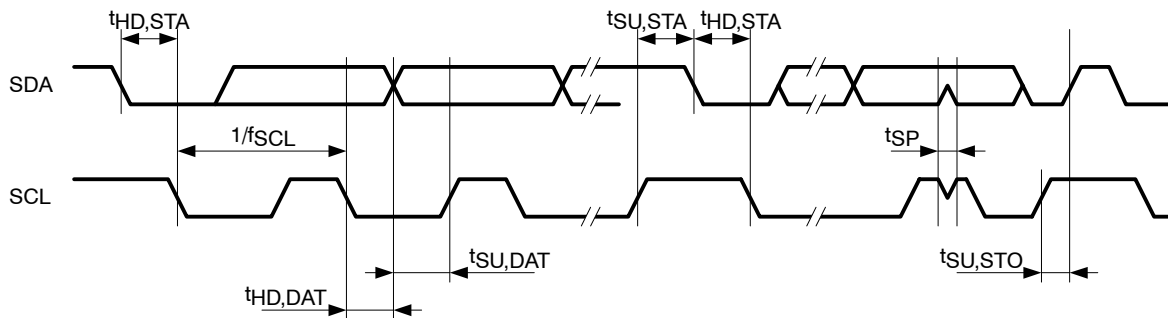

Figure 24. I2C Mode Timing

# MSP430x22x2, MSP430x22x4 MIXED SIGNAL MICROCONTROLLER

SLAS504D - JULY 2006 - REVISED MARCH 2010

**electrical characteristics over recommended ranges of supply voltage and operating free-air temperature (unless otherwise noted) (continued)**

## 10-bit ADC, power supply and input range conditions (see Note 1)

PARAMETER	TEST CONDITIONS	T <sub>A</sub>	V <sub>CC</sub>	MIN	TYP	MAX	UNIT
V <sub>CC</sub>	Analog supply voltage range	V <sub>SS</sub> = 0 V		2.2		3.6	V
V <sub>AX</sub>	Analog input voltage range (see Note 2)	All A <sub>x</sub> terminals. Analog inputs selected in ADC10AE register		0		V <sub>CC</sub>	V
I <sub>ADC10</sub>	ADC10 supply current (see Note 3)	f <sub>ADC10CLK</sub> = 5.0 MHz ADC10ON = 1, REFON = 0, ADC10SHT0 = 1, ADC10SHT1 = 0, ADC10DIV = 0	I: -40-85°C T: -40-105°C	2.2 V	0.52	1.05	mA
				3 V	0.6	1.2	
I <sub>REF+</sub>	Reference supply current, reference buffer disabled (see Note 4)	f <sub>ADC10CLK</sub> = 5.0 MHz, ADC10ON = 0, REF2_5V = 0, REFON = 1, REFOUT = 0	I: -40-85°C T: -40-105°C	2.2 V/3 V	0.25	0.4	mA
			I: -40-85°C T: -40-105°C	3 V			
I <sub>REFB,0</sub>	Reference buffer supply current with ADC10SR = 0 (see Note 4)	f <sub>ADC10CLK</sub> = 5.0 MHz, ADC10ON = 0, REFON = 1, REF2_5V = 0, REFOUT = 1, ADC10SR=0	-40-85°C	2.2 V/3 V	1.1	1.4	mA
			105°C	2.2 V/3 V		1.8	
I <sub>REFB,1</sub>	Reference buffer supply current with ADC10SR = 1 (see Note 4)	f <sub>ADC10CLK</sub> = 5.0 MHz, ADC10ON = 0, REFON = 1, REF2_5V = 0, REFOUT = 1, ADC10SR=1	-40-85°C	2.2 V/3 V	0.5	0.7	mA
			105°C	2.2 V/3 V		0.8	
C <sub>I</sub>	Input capacitance	Only one terminal A <sub>x</sub> selected at a time	I: -40-85°C T: -40-105°C			27	pF
R <sub>I</sub>	Input MUX ON resistance	0V ≤ V <sub>AX</sub> ≤ V <sub>CC</sub>	I: -40-85°C T: -40-105°C	2.2 V/3 V		2000	Ω

- NOTES: 1. The leakage current is defined in the leakage current table with P<sub>x.x</sub>/A<sub>x</sub> parameter.  
 2. The analog input voltage range must be within the selected reference voltage range V<sub>R+</sub> to V<sub>R-</sub> for valid conversion results.  
 3. The internal reference supply current is not included in current consumption parameter I<sub>ADC10</sub>.  
 4. The internal reference current is supplied via terminal V<sub>CC</sub>. Consumption is independent of the ADC10ON control bit, unless a conversion is active. The REFON bit enables the built-in reference to settle before starting an A/D conversion.



electrical characteristics over recommended ranges of supply voltage and operating free-air temperature (unless otherwise noted) (continued)

10-bit ADC, built-in voltage reference

PARAMETER	TEST CONDITIONS	V <sub>CC</sub>	MIN	TYP	MAX	UNIT
V <sub>CC,REF+</sub>	Positive built-in reference analog supply voltage range		2.2			V
			2.8			
			2.9			
V <sub>REF+</sub>	Positive built-in reference voltage	2.2 V/3 V	1.41	1.5	1.59	V
		3 V	2.35	2.5	2.65	
I <sub>LD,VREF+</sub>	Maximum V <sub>REF+</sub> load current	2.2 V	±0.5			mA
		3 V	±1			
V <sub>REF+</sub> load regulation	V <sub>REF+</sub> load regulation	2.2 V/3 V	±2			LSB
		3 V	±2			
V <sub>REF+</sub> load regulation response time	V <sub>REF+</sub> = 100 μA → 900 μA, V <sub>Ax</sub> ≈ 0.5 x V <sub>REF+</sub> , Error of conversion result ≤ 1 LSB	3 V	400			ns
			2000			
C <sub>VREF+</sub>	Max. capacitance at pin V <sub>REF+</sub> (see Note 1)	2.2 V/3 V	100			pF
TC <sub>REF+</sub>	Temperature coefficient	2.2 V/3 V	±100			ppm/°C
t <sub>REFON</sub>	Settling time of internal reference voltage (see Note 2)	3.6 V	30			μs
t <sub>REFBURST</sub>	Settling time of reference buffer (see Note 2)	2.2 V	1			μs
			2.5			
		3 V	2			
			4.5			

- NOTES: 1. The capacitance applied to the internal buffer operational amplifier, if switched to terminal P2.4/TA2/A4/V<sub>REF+</sub>/V<sub>eREF+</sub> (REFOUT=1), must be limited; the reference buffer may become unstable otherwise.  
2. The condition is that the error in a conversion started after t<sub>REFON</sub> or t<sub>RefBuf</sub> is less than ±0.5 LSB.

# MSP430x22x2, MSP430x22x4 MIXED SIGNAL MICROCONTROLLER

SLAS504D - JULY 2006 - REVISED MARCH 2010

**electrical characteristics over recommended ranges of supply voltage and operating free-air temperature (unless otherwise noted) (continued)**

## 10-bit ADC, external reference (see Note 1)

PARAMETER	TEST CONDITIONS	V <sub>CC</sub>	MIN	MAX	UNIT
V <sub>eREF+</sub> Positive external reference input voltage range (see Note 2)	V <sub>eREF+</sub> > V <sub>eREF-</sub> , SREF1 = 1, SREF0 = 0		1.4	V <sub>CC</sub>	V
	V <sub>eREF-</sub> ≤ V <sub>eREF+</sub> ≤ V <sub>CC</sub> - 0.15 V, SREF1 = 1, SREF0 = 1 (see Note 3)		1.4	3.0	
V <sub>eREF-</sub> Negative external reference input voltage range (see Note 4)	V <sub>eREF+</sub> > V <sub>eREF-</sub>		0	1.2	V
ΔV <sub>eREF</sub> Differential external reference input voltage range ΔV <sub>eREF</sub> = V <sub>eREF+</sub> - V <sub>eREF-</sub>	V <sub>eREF+</sub> > V <sub>eREF-</sub> (see Note 5)		1.4	V <sub>CC</sub>	V
I <sub>VeREF+</sub> Static input current into V <sub>eREF+</sub>	0V ≤ V <sub>eREF+</sub> ≤ V <sub>CC</sub> , SREF1 = 1, SREF0 = 0	2.2 V/3 V		±1	μA
	0V ≤ V <sub>eREF+</sub> ≤ V <sub>CC</sub> - 0.15 V ≤ 3 V, SREF1 = 1, SREF0 = 1 (see Note 3)			0	
I <sub>VeREF-</sub> Static input current into V <sub>eREF-</sub>	0V ≤ V <sub>eREF-</sub> ≤ V <sub>CC</sub>	2.2 V/3 V		±1	μA

- NOTES: 1. The external reference is used during conversion to charge and discharge the capacitance array. The input capacitance, C<sub>I</sub>, is also the dynamic load for an external reference during conversion. The dynamic impedance of the reference supply should follow the recommendations on analog-source impedance to allow the charge to settle for 10-bit accuracy.
2. The accuracy limits the minimum positive external reference voltage. Lower reference voltage levels may be applied with reduced accuracy requirements.
3. Under this condition, the external reference is internally buffered. The reference buffer is active and requires the reference buffer supply current I<sub>REFB</sub>. The current consumption can be limited to the sample and conversion period with REBURST = 1.
4. The accuracy limits the maximum negative external reference voltage. Higher reference voltage levels may be applied with reduced accuracy requirements.
5. The accuracy limits the minimum external differential reference voltage. Lower differential reference voltage levels may be applied with reduced accuracy requirements.



**electrical characteristics over recommended ranges of supply voltage and operating free-air temperature (unless otherwise noted) (continued)**

**10-bit ADC, timing parameters**

PARAMETER		TEST CONDITIONS	V <sub>CC</sub>	MIN	TYP	MAX	UNIT
f <sub>ADC10CLK</sub>	ADC10 input clock frequency	For specified performance of ADC10 linearity parameters	2.2 V/3 V	0.45		6.3	MHz
				0.45		1.5	
f <sub>ADC10OSC</sub>	ADC10 built-in oscillator frequency	ADC10DIVx = 0, ADC10SSELx = 0, f <sub>ADC10CLK</sub> = f <sub>ADC10OSC</sub>	2.2 V/3 V	3.7		6.3	MHz
t <sub>CONVERT</sub>	Conversion time	ADC10 built-in oscillator, ADC10SSELx = 0, f <sub>ADC10CLK</sub> = f <sub>ADC10OSC</sub>	2.2 V/3 V	2.06		3.51	μs
		f <sub>ADC10CLK</sub> from ACLK, MCLK or SMCLK, ADC10SSELx ≠ 0		13x ADC10DIVx 1/f <sub>ADC10CLK</sub>			
t <sub>ADC10ON</sub>	Turn on settling time of the ADC	(see Note 1)				100	ns

NOTES: 1. The condition is that the error in a conversion started after t<sub>ADC10ON</sub> is less than ±0.5 LSB. The reference and input signal are already settled.

**10-bit ADC, linearity parameters**

PARAMETER		TEST CONDITIONS	V <sub>CC</sub>	MIN	TYP	MAX	UNIT
E <sub>I</sub>	Integral linearity error		2.2 V/3 V			±1	LSB
E <sub>D</sub>	Differential linearity error		2.2 V/3 V			±1	LSB
E <sub>O</sub>	Offset error	Source impedance R <sub>S</sub> < 100 Ω,	2.2 V/3 V			±1	LSB
E <sub>G</sub>	Gain error	SREFx = 010, unbuffered external reference, V <sub>eREF+</sub> = 1.5 V	2.2 V		±1.1	±2	LSB
		SREFx = 010, unbuffered external reference, V <sub>eREF+</sub> = 2.5 V	3 V		±1.1	±2	
		SREFx = 011, buffered external reference (see Note 1), V <sub>eREF+</sub> = 1.5 V	2.2 V		±1.1	±4	
		SREFx = 011, buffered external reference (see Note 1), V <sub>eREF+</sub> = 2.5 V	3 V		±1.1	±3	
E <sub>T</sub>	Total unadjusted error	SREFx = 010, unbuffered external reference, V <sub>eREF+</sub> = 1.5 V	2.2 V		±2	±5	LSB
		SREFx = 010, unbuffered external reference, V <sub>eREF+</sub> = 2.5 V	3 V		±2	±5	
		SREFx = 011, buffered external reference (see Note 1), V <sub>eREF+</sub> = 1.5 V	2.2 V		±2	±7	
		SREFx = 011, buffered external reference (see Note 1), V <sub>eREF+</sub> = 2.5 V	3 V		±2	±6	

NOTES: 1. The reference buffer offset adds to the gain and total unadjusted error.

# MSP430x22x2, MSP430x22x4 MIXED SIGNAL MICROCONTROLLER

SLAS504D - JULY 2006 - REVISED MARCH 2010

electrical characteristics over recommended ranges of supply voltage and operating free-air temperature (unless otherwise noted) (continued)

## 10-bit ADC, temperature sensor and built-in $V_{MID}$

PARAMETER		TEST CONDITIONS	$V_{CC}$	MIN	TYP	MAX	UNIT	
$I_{SENSOR}$	Temperature sensor supply current (see Note 1)	REFON = 0, INCHx = 0Ah, $T_A = 25^\circ\text{C}$	2.2 V		40	120	$\mu\text{A}$	
			3 V		60	160		
$TC_{SENSOR}^\dagger$		ADC10ON = 1, INCHx = 0Ah (see Note 2)	2.2 V/3 V	3.44	3.55	3.66	$\text{mV}/^\circ\text{C}$	
$V_{Offset, Sensor}$	Sensor offset voltage	ADC10ON = 1, INCHx = 0Ah (see Note 2)		-100		100	mV	
$V_{Sensor}$	Sensor output voltage (see Note 3)		Temperature sensor voltage at $T_A = 105^\circ\text{C}$ (T version only)	2.2 V/3 V	1265	1365	1465	mV
			Temperature sensor voltage at $T_A = 85^\circ\text{C}$	2.2 V/3 V	1195	1295	1395	
			Temperature sensor voltage at $T_A = 25^\circ\text{C}$	2.2 V/3 V	985	1085	1185	
			Temperature sensor voltage at $T_A = 0^\circ\text{C}$	2.2 V/3 V	895	995	1095	
$t_{Sensor(sample)}$	Sample time required if channel 10 is selected (see Note 4)	ADC10ON = 1, INCHx = 0Ah, Error of conversion result $\leq 1$ LSB	2.2 V/3 V	30			$\mu\text{s}$	
$I_{VMID}$	Current into divider at channel 11 (see Note 5)	ADC10ON = 1, INCHx = 0Bh	2.2 V			NA	$\mu\text{A}$	
			3 V			NA		
$V_{MID}$	$V_{CC}$ divider at channel 11	ADC10ON = 1, INCHx = 0Bh, $V_{MID}$ is $\approx 0.5 \times V_{CC}$	2.2 V	1.06	1.1	1.14	V	
			3 V	1.46	1.5	1.54		
$t_{VMID(sample)}$	Sample time required if channel 11 is selected (see Note 6)	ADC10ON = 1, INCHx = 0Bh, Error of conversion result $\leq 1$ LSB	2.2 V	1400			ns	
			3 V	1220				

- NOTES: 1. The sensor current  $I_{SENSOR}$  is consumed if (ADC10ON = 1 and REFON = 1), or (ADC10ON = 1 and INCH = 0Ah and sample signal is high). When REFON = 1,  $I_{SENSOR}$  is included in  $I_{REF+}$ . When REFON = 0,  $I_{SENSOR}$  applies during conversion of the temperature sensor input (INCH = 0Ah).
2. The following formula can be used to calculate the temperature sensor output voltage:  
 $V_{Sensor,typ} = TC_{Sensor} (273 + T [^\circ\text{C}]) + V_{Offset,sensor} [\text{mV}]$  or  
 $V_{Sensor,typ} = TC_{Sensor} T [^\circ\text{C}] + V_{Sensor}(T_A = 0^\circ\text{C}) [\text{mV}]$
3. Results based on characterization and/or production test, not  $TC_{Sensor}$  or  $V_{Offset,sensor}$ .
4. The typical equivalent impedance of the sensor is 51 k $\Omega$ . The sample time required includes the sensor-on time  $t_{SENSOR(on)}$ .
5. No additional current is needed. The  $V_{MID}$  is used during sampling.
6. The on time,  $t_{VMID(on)}$ , is included in the sampling time,  $t_{VMID(sample)}$ ; no additional on time is needed.



**electrical characteristics over recommended ranges of supply voltage and operating free-air temperature (unless otherwise noted) (continued)**

**operational amplifier OA, supply specifications (MSP430x22x4 only)**

PARAMETER	TEST CONDITIONS	V <sub>CC</sub>	MIN	TYP	MAX	UNIT	
V <sub>CC</sub>	Supply voltage range		2.2		3.6	V	
I <sub>CC</sub>	Supply current (see Note 1)	2.2 V/3 V		Fast Mode	180	290	μA
				Medium Mode	110	190	
				Slow Mode	50	80	
PSRR	Power supply rejection ratio	2.2 V/3 V		70		dB	

NOTES: 1. Corresponding pins configured as OA inputs and outputs respectively.

**operational amplifier OA, input/output specifications (MSP430x22x4 only)**

PARAMETER	TEST CONDITIONS	V <sub>CC</sub>	MIN	TYP	MAX	UNIT		
V <sub>I/P</sub>	Input voltage range		-0.1	V <sub>CC</sub> -1.2		V		
I <sub>lkg</sub>	Input leakage current (see Notes 1 and 2)	2.2 V/3 V		T <sub>A</sub> = -40 to +55°C	-5	±0.5	5	nA
				T <sub>A</sub> = +55 to +85°C	-20	±5	20	
				T <sub>A</sub> = +85 to +105°C	-50		50	
V <sub>n</sub>	Voltage noise density, I/P	2.2 V/3 V		f <sub>V(I/P)</sub> = 1 kHz	Fast Mode		50	nV/√Hz
					Medium Mode		80	
					Slow Mode		140	
				f <sub>V(I/P)</sub> = 10 kHz	Fast Mode		30	
					Medium Mode		50	
					Slow Mode		65	
V <sub>IO</sub>	Offset voltage, I/P	2.2 V/3 V			±10	mV		
	Offset temperature drift, I/P	2.2 V/3 V		see Note 3	±10	μV/°C		
	Offset voltage drift with supply, I/P	2.2 V/3 V		0.3 V ≤ V <sub>IN</sub> ≤ V <sub>CC</sub> -1.0 V ΔV <sub>CC</sub> ≤ ± 10%, T <sub>A</sub> = 25°C		±1.5	mV/V	
V <sub>OH</sub>	High-level output voltage, O/P	2.2 V/3 V		Fast Mode, I <sub>SOURCE</sub> ≤ -500 μA	V <sub>CC</sub> -0.2	V <sub>CC</sub>	V	
				Slow Mode, I <sub>SOURCE</sub> ≤ -150 μA	V <sub>CC</sub> -0.1	V <sub>CC</sub>		
V <sub>OL</sub>	Low-level output voltage, O/P	2.2 V/3 V		Fast Mode, I <sub>SOURCE</sub> ≤ +500 μA	V <sub>SS</sub>	0.2	V	
				Slow Mode, I <sub>SOURCE</sub> ≤ +150 μA	V <sub>SS</sub>	0.1		
R <sub>O/P(OAx)</sub>	Output resistance (see Figure 25 and Note 4)	2.2 V/3 V		R <sub>Load</sub> = 3 kΩ, C <sub>Load</sub> = 50pF, V <sub>O/P(OAx)</sub> < 0.2 V		150	250	Ω
				R <sub>Load</sub> = 3 kΩ, C <sub>Load</sub> = 50pF, V <sub>O/P(OAx)</sub> > V <sub>CC</sub> - 1.2 V		150	250	
				R <sub>Load</sub> = 3 kΩ, C <sub>Load</sub> = 50pF, 0.2 V ≤ V <sub>O/P(OAx)</sub> ≤ V <sub>CC</sub> - 0.2 V		0.1	4	
CMRR	Common-mode rejection ratio	2.2 V/3 V			70		dB	

- NOTES: 1. ESD damage can degrade input current leakage.  
 2. The input bias current is overridden by the input leakage current.  
 3. Calculated using the box method  
 4. Specification valid for voltage-follower OAx configuration

# MSP430x22x2, MSP430x22x4 MIXED SIGNAL MICROCONTROLLER

SLAS504D - JULY 2006 - REVISED MARCH 2010

electrical characteristics over recommended ranges of supply voltage and operating free-air temperature (unless otherwise noted) (continued)

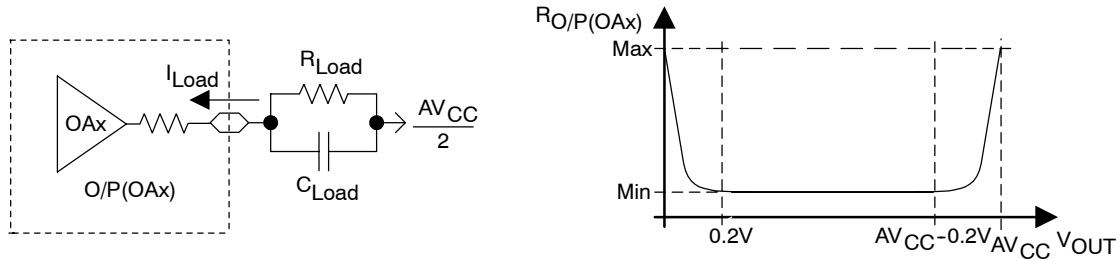

Figure 25. OAx Output Resistance Tests

operational amplifier OA, dynamic specifications (MSP430x22x4 only)

PARAMETER	TEST CONDITIONS	V <sub>CC</sub>	MIN	TYP	MAX	UNIT	
SR	Fast Mode	2.2 V/3 V		1.2		V/μs	
	Medium Mode			0.8			
	Slow Mode			0.3			
	Open-loop voltage gain			100		dB	
φ <sub>m</sub>	Phase margin	C <sub>L</sub> = 50 pF		60		deg	
	Gain margin	C <sub>L</sub> = 50 pF		20		dB	
GBW	Noninverting, Fast Mode, R <sub>L</sub> = 47 kΩ, C <sub>L</sub> = 50 pF	2.2 V/3 V		2.2		MHz	
	Noninverting, Medium Mode, R <sub>L</sub> = 300 kΩ, C <sub>L</sub> = 50 pF			1.4			
	Non-inverting, Slow Mode, R <sub>L</sub> = 300 kΩ, C <sub>L</sub> = 50 pF			0.5			
t <sub>en(on)</sub>	Enable time on	t <sub>on</sub> , Noninverting, Gain = 1	2.2 V/3 V		10	20	μs
t <sub>en(off)</sub>	Enable time off		2.2 V/3 V			1	μs

TYPICAL OPEN-LOOP GAIN vs FREQUENCY

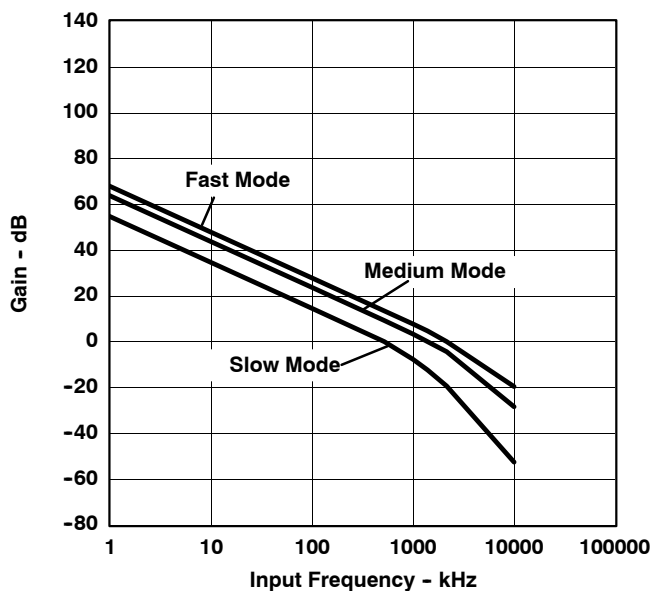

Figure 26

TYPICAL PHASE vs FREQUENCY

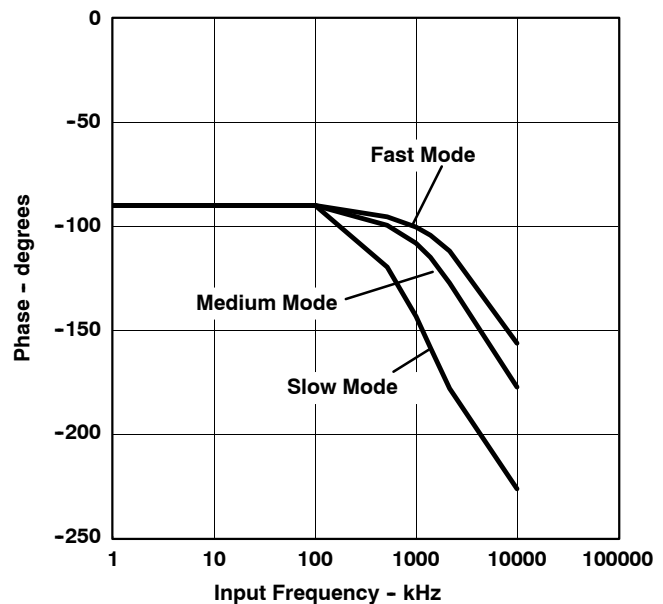

Figure 27

# MSP430x22x2, MSP430x22x4 MIXED SIGNAL MICROCONTROLLER

SLAS504D - JULY 2006 - REVISED MARCH 2010

electrical characteristics over recommended ranges of supply voltage and operating free-air temperature (unless otherwise noted) (continued)

## operational amplifier OA feedback network, resistor network (MSP430x22x4 only) (see Note 1)

PARAMETER	TEST CONDITIONS	V <sub>CC</sub>	MIN	TYP	MAX	UNIT
R <sub>total</sub>	Total resistance of resistor string		76	96	128	kΩ
R <sub>unit</sub>	Unit resistor of resistor string (see Note 2)		4.8	6	8	kΩ

NOTES: 1. A single resistor string is composed of 4 R<sub>unit</sub> + 4 R<sub>unit</sub> + 2 R<sub>unit</sub> + 2 R<sub>unit</sub> + 1 R<sub>unit</sub> + 1 R<sub>unit</sub> + 1 R<sub>unit</sub> + 1 R<sub>unit</sub> = 16 R<sub>unit</sub> = R<sub>total</sub>.  
2. For the matching (i.e. the relative accuracy) of the unit resistors on a device refer to the gain and level specifications of the respective configurations.

## operational amplifier OA feedback network, comparator mode (OAFcx = 3) (MSP430x22x4 only)

PARAMETER	TEST CONDITIONS	V <sub>CC</sub>	MIN	TYP	MAX	UNIT							
V <sub>Level</sub>	Comparator level	2.2 V/ 3 V				V <sub>CC</sub>							
							OAFBRx = 1, OARRIP = 0	0.245	1/4	0.255			
							OAFBRx = 2, OARRIP = 0	0.495	1/2	0.505			
							OAFBRx = 3, OARRIP = 0	0.619	5/8	0.631			
							OAFBRx = 4, OARRIP = 0	N/A (see Note 1)					
							OAFBRx = 5, OARRIP = 0	N/A (see Note 1)					
							OAFBRx = 6, OARRIP = 0	N/A (see Note 1)					
							OAFBRx = 7, OARRIP = 0	N/A (see Note 1)					
							OAFBRx = 1, OARRIP = 1	0.061	1/16	0.065			
							OAFBRx = 2, OARRIP = 1	0.122	1/8	0.128			
							OAFBRx = 3, OARRIP = 1	0.184	3/16	0.192			
							OAFBRx = 4, OARRIP = 1	0.245	1/4	0.255			
							OAFBRx = 5, OARRIP = 1	0.367	3/8	0.383			
							OAFBRx = 6, OARRIP = 1	0.495	1/2	0.505			
							OAFBRx = 7, OARRIP = 1	N/A (see Note 1)					
							t <sub>PLH</sub> , t <sub>PHL</sub>	Propagation delay (low-high and high-low)	2.2 V/ 3 V				μs
Fast Mode, Overdrive 100 mV	4												
Fast Mode, Overdrive 500 mV	3												
Medium Mode, Overdrive 10 mV	60												
Medium Mode, Overdrive 100 mV	6												
Medium Mode, Overdrive 500 mV	5												
Slow Mode, Overdrive 10 mV	160												
Slow Mode, Overdrive 100 mV	20												
Slow Mode, Overdrive 500 mV	15												

NOTES: 1. The level is not available due to the analog input voltage range of the operational amplifier.



# MSP430x22x2, MSP430x22x4 MIXED SIGNAL MICROCONTROLLER

SLAS504D - JULY 2006 - REVISED MARCH 2010

electrical characteristics over recommended ranges of supply voltage and operating free-air temperature (unless otherwise noted) (continued)

## operational amplifier OA feedback network, noninverting amplifier mode (OAF<sub>Cx</sub> = 4) (MSP430x22x4 only)

PARAMETER	TEST CONDITIONS	V <sub>CC</sub>	MIN	TYP	MAX	UNIT	
G	Gain	2.2 V/ 3 V	OAFBR <sub>x</sub> = 0	0.998	1.00	1.002	
			OAFBR <sub>x</sub> = 1	1.328	1.334	1.340	
			OAFBR <sub>x</sub> = 2	1.985	2.001	2.017	
			OAFBR <sub>x</sub> = 3	2.638	2.667	2.696	
			OAFBR <sub>x</sub> = 4	3.94	4.00	4.06	
			OAFBR <sub>x</sub> = 5	5.22	5.33	5.44	
			OAFBR <sub>x</sub> = 6	7.76	7.97	8.18	
			OAFBR <sub>x</sub> = 7	15.0	15.8	16.6	
THD	Total harmonic distortion/ nonlinearity	All gains	2.2 V	-60		dB	
			3 V	-70			
t <sub>Settle</sub>	Settling time (see Note 1)	All power modes	2.2 V/3 V	7	12	μs	

NOTES: 1. The settling time specifies the time until an ADC result is stable. This includes the minimum required sampling time of the ADC. The settling time of the amplifier itself might be faster.

## operational amplifier OA feedback network, inverting amplifier mode (OAF<sub>Cx</sub> = 6) (MSP430x22x4 only) (see Note 1)

PARAMETER	TEST CONDITIONS	V <sub>CC</sub>	MIN	TYP	MAX	UNIT	
G	Gain	2.2 V/ 3 V	OAFBR <sub>x</sub> = 1	-0.345	-0.335	-0.325	
			OAFBR <sub>x</sub> = 2	-1.023	-1.002	-0.979	
			OAFBR <sub>x</sub> = 3	-1.712	-1.668	-1.624	
			OAFBR <sub>x</sub> = 4	-3.10	-3.00	-2.90	
			OAFBR <sub>x</sub> = 5	-4.51	-4.33	-4.15	
			OAFBR <sub>x</sub> = 6	-7.37	-6.97	-6.57	
			OAFBR <sub>x</sub> = 7	-16.3	-14.8	-13.1	
THD	Total harmonic distortion/ nonlinearity	All gains	2.2 V	-60		dB	
			3 V	-70			
t <sub>Settle</sub>	Settling time (see Note 2)	All power modes	2.2 V/3 V	7	12	μs	

NOTES: 1. This includes the 2 OA configuration "inverting amplifier with input buffer". Both OA needs to be set to the same power mode OAPM<sub>x</sub>.  
2. The settling time specifies the time until an ADC result is stable. This includes the minimum required sampling time of the ADC. The settling time of the amplifier itself might be faster.



**electrical characteristics over recommended ranges of supply voltage and operating free-air temperature (unless otherwise noted) (continued)**

**flash memory**

PARAMETER		TEST CONDITIONS	V <sub>CC</sub>	MIN	TYP	MAX	UNIT
V <sub>CC(PGM/ERASE)</sub>	Program and erase supply voltage			2.2		3.6	V
f <sub>FTG</sub>	Flash timing generator frequency			257		476	kHz
I <sub>PGM</sub>	Supply current from V <sub>CC</sub> during program		2.2 V/3.6 V		1	5	mA
I <sub>ERASE</sub>	Supply current from V <sub>CC</sub> during erase		2.2 V/3.6 V		1	7	mA
t <sub>CPT</sub>	Cumulative program time (see Note 1)		2.2 V/3.6 V			10	ms
t <sub>CMErase</sub>	Cumulative mass erase time		2.2 V/3.6 V	20			ms
	Program/erase endurance			10 <sup>4</sup>	10 <sup>5</sup>		cycles
t <sub>Retention</sub>	Data retention duration	T <sub>J</sub> = 25°C		100			years
t <sub>Word</sub>	Word or byte program time	see Note 2			30		t <sub>FTG</sub>
t <sub>Block, 0</sub>	Block program time for first byte or word	see Note 2			25		
t <sub>Block, 1-63</sub>	Block program time for each additional byte or word	see Note 2			18		
t <sub>Block, End</sub>	Block program end-sequence wait time	see Note 2			6		
t <sub>Mass Erase</sub>	Mass erase time	see Note 2			10593		
t <sub>Seg Erase</sub>	Segment erase time	see Note 2			4819		

- NOTES: 1. The cumulative program time must not be exceeded when writing to a 64-byte flash block. This parameter applies to all programming methods: individual word/byte write and block write modes.  
2. These values are hardwired into the flash controller's state machine (t<sub>FTG</sub> = 1/f<sub>FTG</sub>).

**RAM**

PARAMETER		TEST CONDITIONS	MIN	TYP	MAX	UNIT
V <sub>(RAMh)</sub>	RAM retention supply voltage (see Note 1)	CPU halted	1.6			V

NOTE 1: This parameter defines the minimum supply voltage V<sub>CC</sub> when the data in RAM remains unchanged. No program execution should happen during this supply voltage condition.

# MSP430x22x2, MSP430x22x4 MIXED SIGNAL MICROCONTROLLER

SLAS504D - JULY 2006 - REVISED MARCH 2010

**electrical characteristics over recommended ranges of supply voltage and operating free-air temperature (unless otherwise noted) (continued)**

## JTAG and Spy-Bi-Wire interface

PARAMETER		TEST CONDITIONS	V <sub>CC</sub>	MIN	TYP	MAX	UNIT
f <sub>SBW</sub>	Spy-Bi-Wire input frequency		2.2 V / 3 V	0		20	MHz
t <sub>SBW,Low</sub>	Spy-Bi-Wire low clock pulse length		2.2 V / 3 V	0.025		15	μs
t <sub>SBW,En</sub>	Spy-Bi-Wire enable time (TEST high to acceptance of first clock edge, see Note 1)		2.2 V / 3 V			1	μs
t <sub>SBW,Ret</sub>	Spy-Bi-Wire return to normal operation time		2.2 V / 3 V	15		100	μs
f <sub>TCK</sub>	TCK input frequency (see Note 2)		2.2 V	0		5	MHz
			3 V	0		10	
R <sub>Internal</sub>	Internal pull-down resistance on TEST		2.2 V / 3 V	25	60	90	kΩ

- NOTES: 1. Tools accessing the Spy-Bi-Wire interface need to wait for the maximum t<sub>SBW,En</sub> time after pulling the TEST/SBWCLK pin high before applying the first SBWCLK clock edge.  
2. f<sub>TCK</sub> may be restricted to meet the timing requirements of the module selected.

## JTAG fuse (see Note 1)

PARAMETER		TEST CONDITIONS	V <sub>CC</sub>	MIN	TYP	MAX	UNIT
V <sub>CC(FB)</sub>	Supply voltage during fuse-blow condition	T <sub>A</sub> = 25°C		2.5			V
V <sub>FB</sub>	Voltage level on TEST for fuse blow			6		7	V
I <sub>FB</sub>	Supply current into TEST during fuse blow					100	mA
t <sub>FB</sub>	Time to blow fuse					1	ms

- NOTES: 1. Once the fuse is blown, no further access to the JTAG/Test and emulation feature is possible, and it is switched to bypass mode.



APPLICATION INFORMATION

Port P1 pin schematic: P1.0 to P1.3, input/output with Schmitt trigger

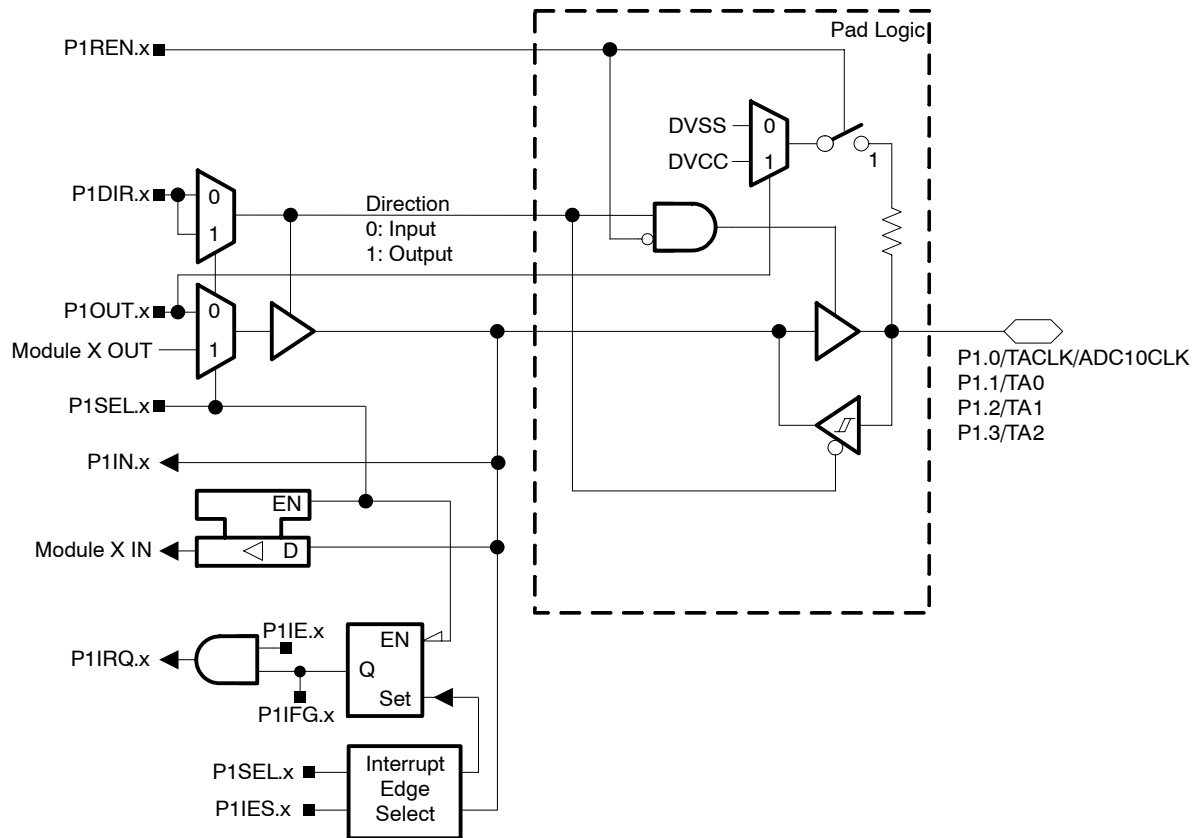

Port P1 (P1.0 to P1.3) pin functions

PIN NAME (P1.x)	x	FUNCTION	CONTROL BITS / SIGNALS	
			P1DIR.x	P1SEL.x
P1.0/ TACLK/ADC10CLK	0	P1.0† (I/O)	I: 0; O: 1	0
		Timer_A3.TACLK	0	1
		ADC10CLK	1	1
P1.1/TA0	1	P1.1† (I/O)	I: 0; O: 1	0
		Timer_A3.CCI0A	0	1
		Timer_A3.TA0	1	1
P1.2/TA1	2	P1.2† (I/O)	I: 0; O: 1	0
		Timer_A3.CCI0A	0	1
		Timer_A3.TA0	1	1
P1.3/TA2	3	P1.3† (I/O)	I: 0; O: 1	0
		Timer_A3.CCI0A	0	1
		Timer_A3.TA0	1	1

† Default after reset (PUC/POR)

NOTES: 1. N/A: Not available or not applicable

# MSP430x22x2, MSP430x22x4 MIXED SIGNAL MICROCONTROLLER

SLAS504D - JULY 2006 - REVISED MARCH 2010

## Port P1 pin schematic: P1.4 to P1.6, input/output with Schmitt trigger and in-system access features

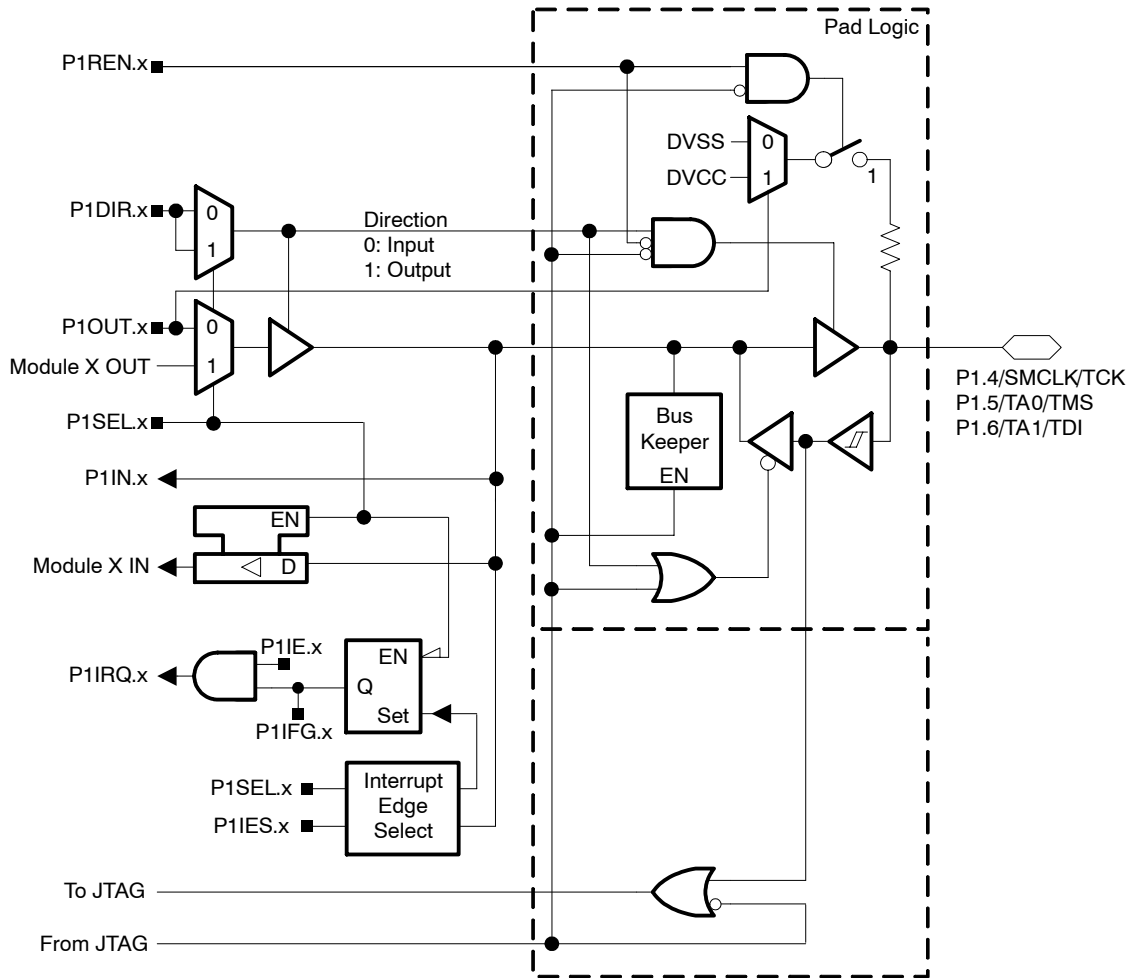

### Port P1 (P1.4 to P1.6) pin functions

PIN NAME (P1.x)	x	FUNCTION	CONTROL BITS / SIGNALS		
			P1DIR.x	P1SEL.x	4-Wire JTAG
P1.4/SMCLK/TCK	4	P1.4† (I/O)	I: 0; O: 1	0	0
		SMCLK	1	1	0
		TCK	X	X	1
P1.5/TA0/TMS	5	P1.5† (I/O)	I: 0; O: 1	0	0
		Timer_A3.TA0	1	1	0
		TMS	X	X	1
P1.6/TA1/TDI/TCLK	6	P1.6† (I/O)	I: 0; O: 1	0	0
		Timer_A3.TA1	1	1	0
		TDI/TCLK (see Note 3)	X	X	1

† Default after reset (PUC/POR)

- NOTES: 1. N/A: Not available or not applicable  
 2. X: Don't care  
 3. Function controlled by JTAG.



Port P1 pin schematic: P1.7, input/output with Schmitt trigger and in-system access features

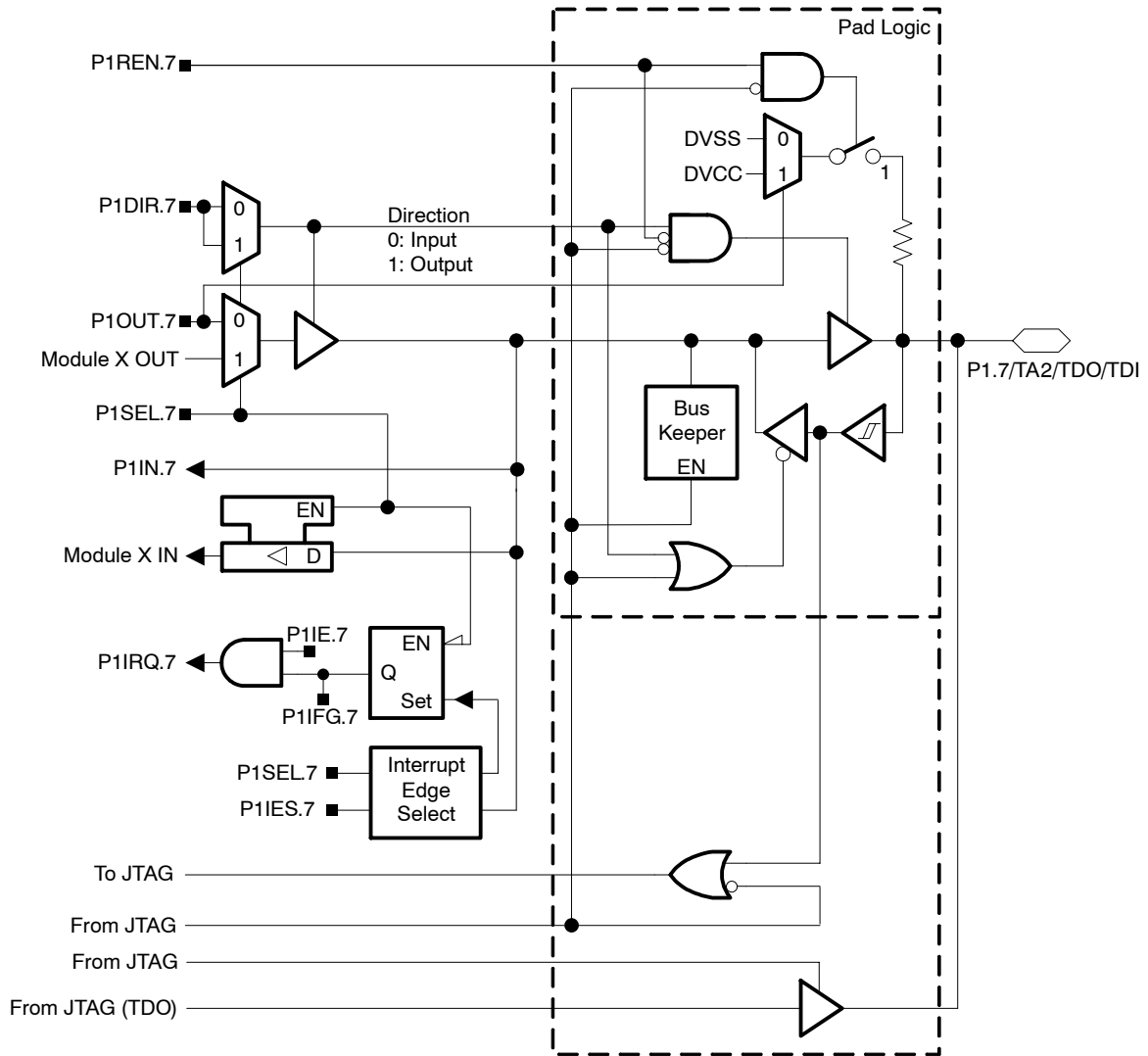

Port P1 (P1.7) pin functions

PIN NAME (P1.x)	x	FUNCTION	CONTROL BITS / SIGNALS		
			P1DIR.x	P1SEL.x	4-Wire JTAG
P1.7/TA2/TDO/TDI	7	P1.7† (I/O)	I: 0; O: 1	0	0
		Timer_A3.TA2	1	1	0
		TDO/TDI (see Note 3)	X	X	1

† Default after reset (PUC/POR)

- NOTES: 1. N/A: Not available or not applicable  
2. X: Don't care  
3. Function controlled by JTAG.

# MSP430x22x2, MSP430x22x4 MIXED SIGNAL MICROCONTROLLER

SLAS504D - JULY 2006 - REVISED MARCH 2010

## Port P2 pin schematic: P2.0, P2.2, input/output with Schmitt trigger

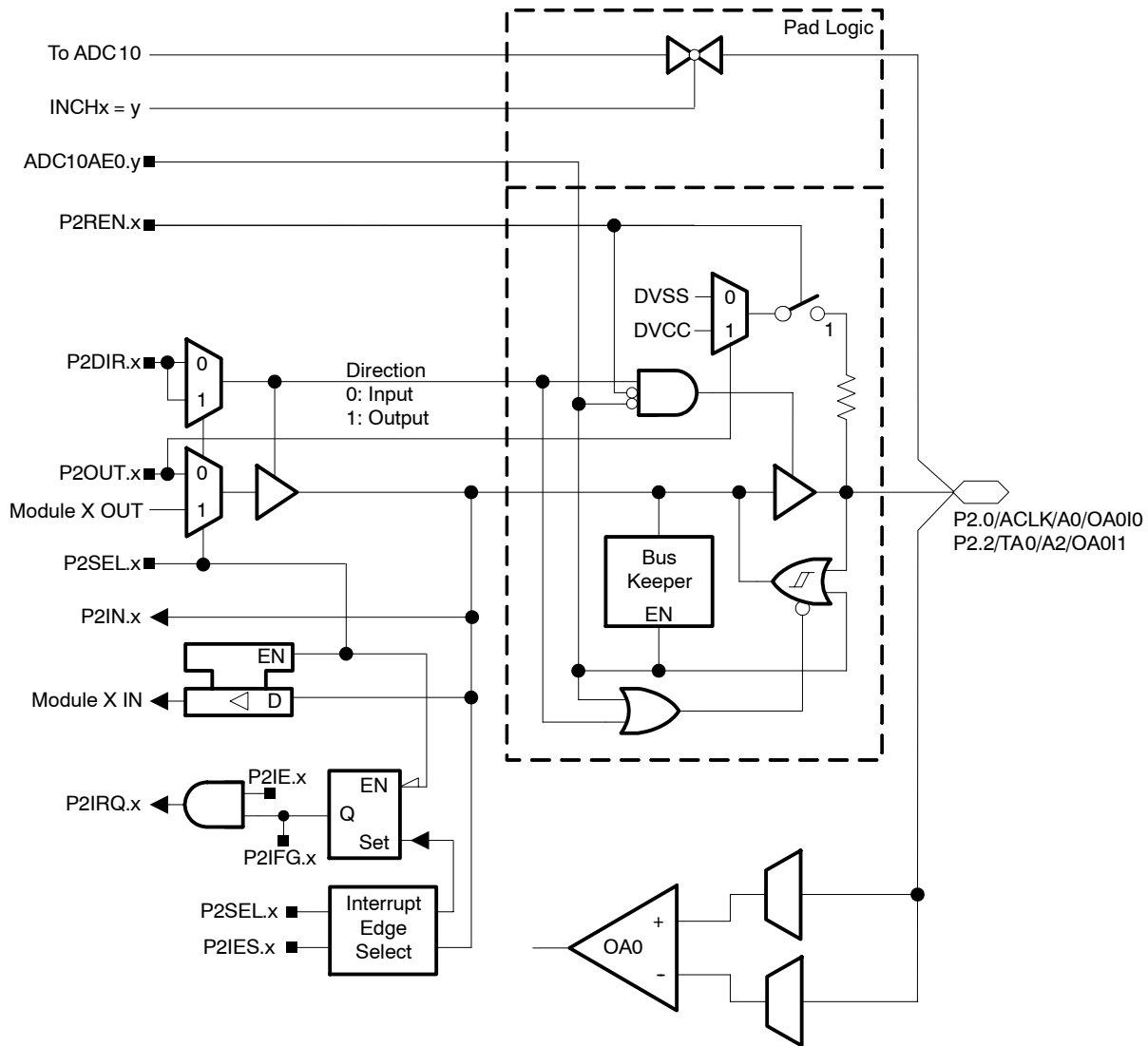

## Port P2 (P2.0, P2.2) pin functions

PIN NAME (P2.x)	x	y	FUNCTION	CONTROL BITS / SIGNALS		
				P2DIR.x	P2SEL.x	ADC10AE0.y
P2.0/ACLK/A0/OA0I0	0	0	P2.0† (I/O)	I: 0; O: 1	0	0
			ACLK	1	1	0
			A0/OA0I0 (see Note 3)	X	X	1
P2.2/TA0/A2/OA0I1	2	2	P2.2† (I/O)	I: 0; O: 1	0	0
			Timer_A3.CCI0B	0	1	0
			Timer_A3.TA0	1	1	0
			A2/OA0I1 (see Note 3)	X	X	1

† Default after reset (PUC/POR)

NOTES: 1. N/A: Not available or not applicable

2. X: Don't care

3. Setting the ADC10AE0.y bit disables the output driver as well as the input schmitt trigger to prevent parasitic cross currents when applying analog signals.



POST OFFICE BOX 655303 • DALLAS, TEXAS 75265

Port P2 pin schematic: P2.1, input/output with Schmitt trigger

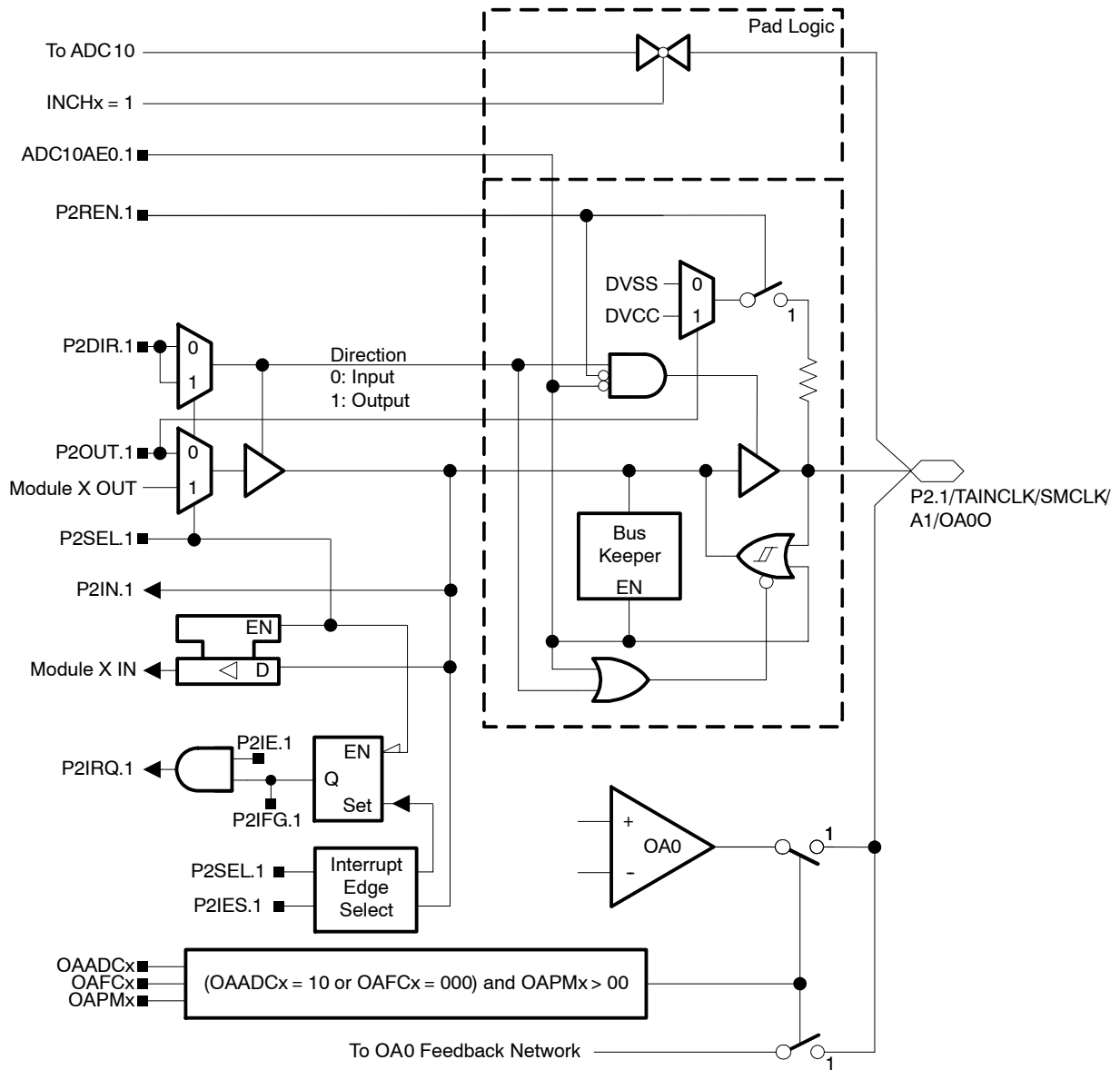

# MSP430x22x2, MSP430x22x4 MIXED SIGNAL MICROCONTROLLER

SLAS504D - JULY 2006 - REVISED MARCH 2010

## Port P2 pin schematic: P2.3, input/output with Schmitt trigger

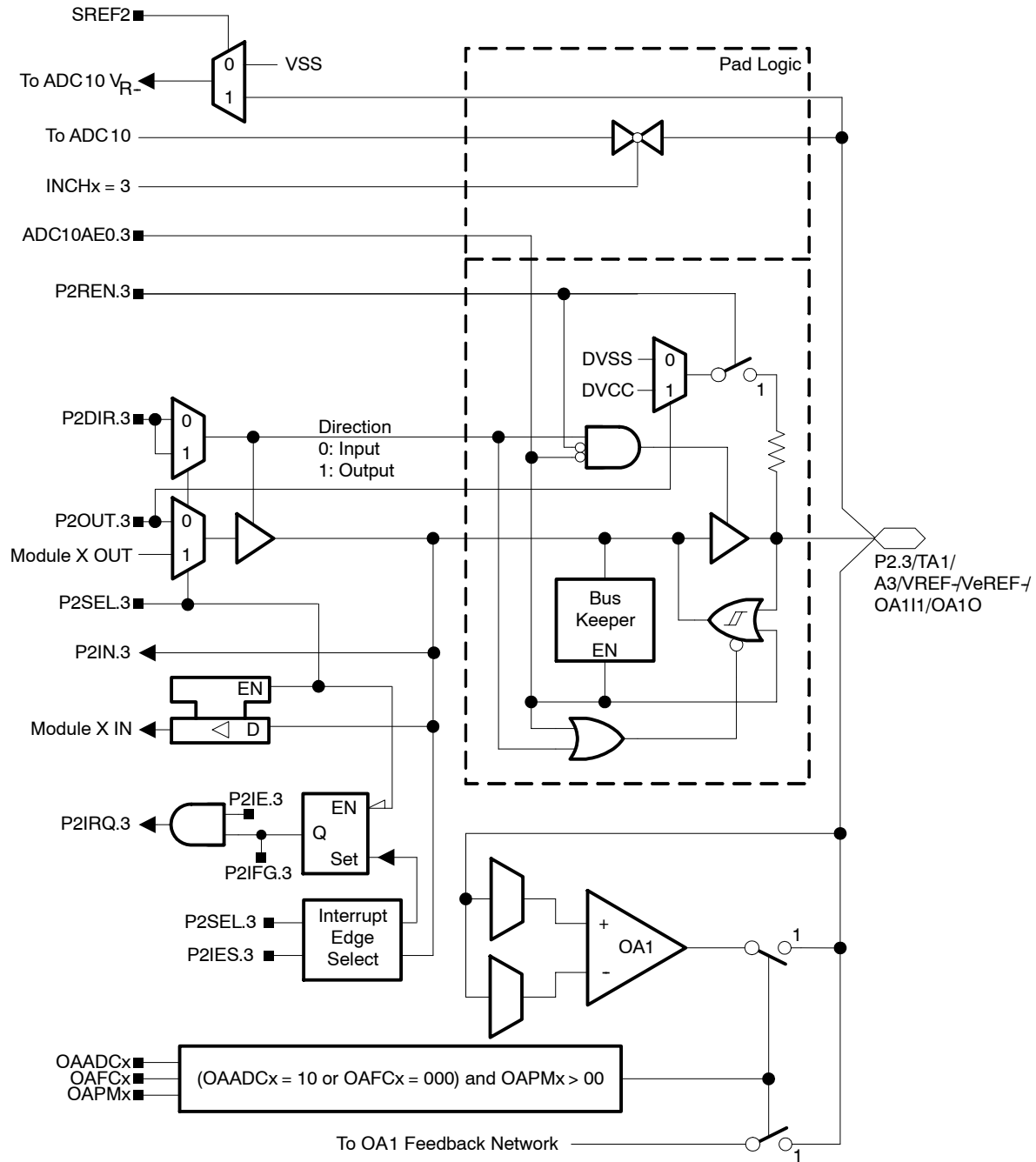

## Port P2 (P2.1) pin functions

PIN NAME (P2.x)	x	y	FUNCTION	CONTROL BITS / SIGNALS		
				P2DIR.x	P2SEL.x	ADC10AE0.y
P2.1/TAINCLK/SMCLK /A1/OA00	1	1	P2.1† (I/O)	I: 0; O: 1	0	0
			Timer_A3.INCLK	0	1	0
			SMCLK	1	1	0
			A1/OA00 (see Note 3)	X	X	1

† Default after reset (PUC/POR)

- NOTES:
1. N/A: Not available or not applicable
  2. X: Don't care
  3. Setting the ADC10AE0.y bit disables the output driver as well as the input schmitt trigger to prevent parasitic cross currents when applying analog signals.

## Port P2 (P2.3) pin functions

PIN NAME (P2.x)	x	y	FUNCTION	CONTROL BITS / SIGNALS		
				P2DIR.x	P2SEL.x	ADC10AE0.y
P2.3/TA1/ A3/V <sub>REF-</sub> /V <sub>eREF-</sub> / OA111/OA10	3	3	P2.3† (I/O)	I: 0; O: 1	0	0
			Timer_A3.CCI1B	0	1	0
			Timer_A3.TA1	1	1	0
			A3/V <sub>REF-</sub> /V <sub>eREF-</sub> /OA111/OA10 (see Note 3)	X	X	1

† Default after reset (PUC/POR)

- NOTES:
1. N/A: Not available or not applicable
  2. X: Don't care
  3. Setting the ADC10AE0.y bit disables the output driver as well as the input schmitt trigger to prevent parasitic cross currents when applying analog signals.

# MSP430x22x2, MSP430x22x4 MIXED SIGNAL MICROCONTROLLER

SLAS504D - JULY 2006 - REVISED MARCH 2010

## Port P2 pin schematic: P2.4, input/output with Schmitt trigger

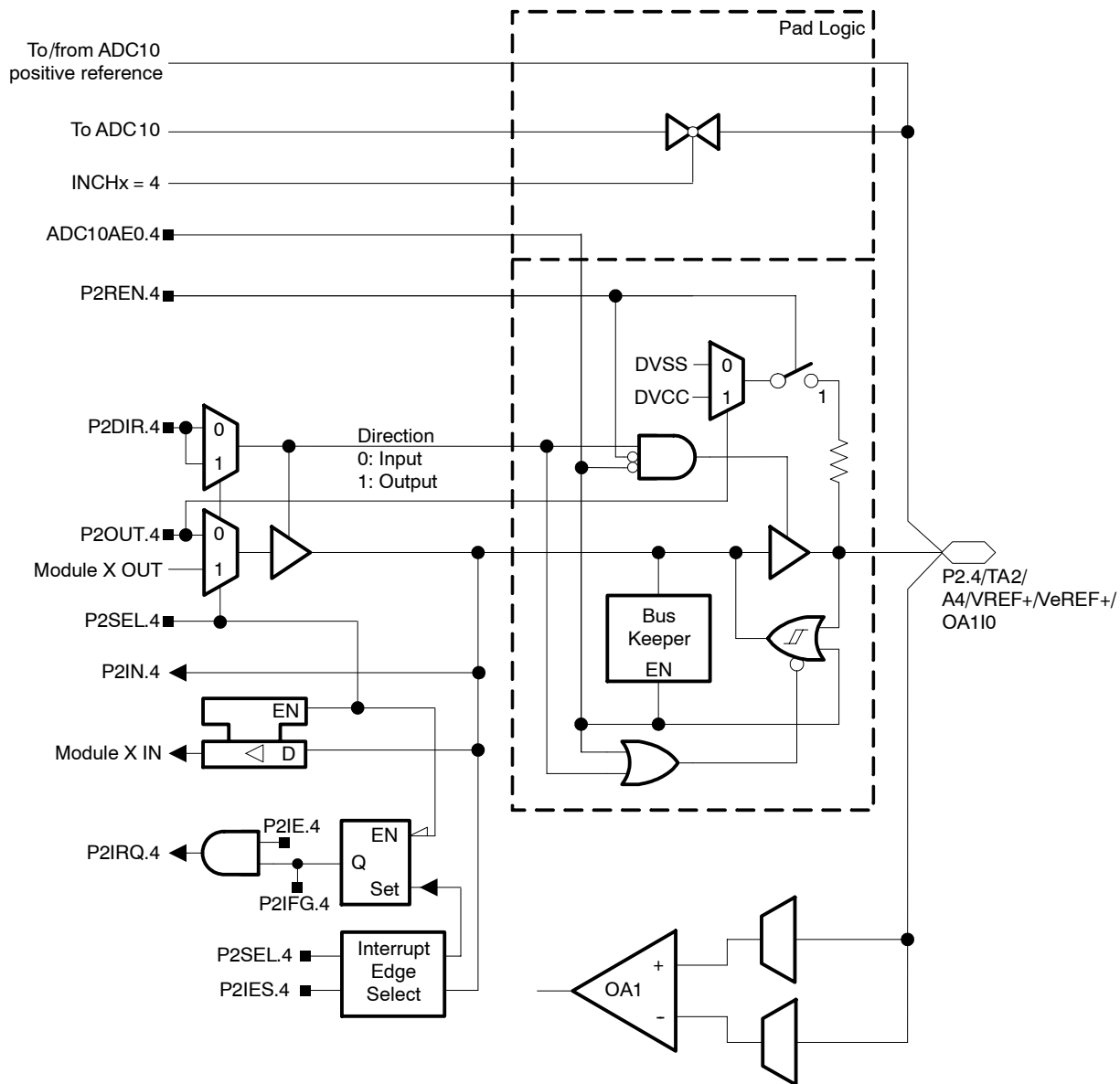

### Port P2 (P2.4) pin functions

PIN NAME (P2.x)	x	y	FUNCTION	CONTROL BITS / SIGNALS		
				P2DIR.x	P2SEL.x	ADC10AE0.y
P2.4/TA2/ A4/VREF+/VeREF+/ OA110	4	4	P2.4† (I/O)	I: 0; O: 1	0	0
			Timer_A3.TA2	1	1	0
			A4/VREF+/VeREF+/OA110 (see Note 3)	X	X	1

† Default after reset (PUC/POR)

NOTES: 1. N/A: Not available or not applicable

2. X: Don't care

3. Setting the ADC10AE0.y bit disables the output driver as well as the input schmitt trigger to prevent parasitic cross currents when applying analog signals.



## Port P2 pin schematic: P2.5, input/output with Schmitt trigger and external R<sub>OSC</sub> for DCO

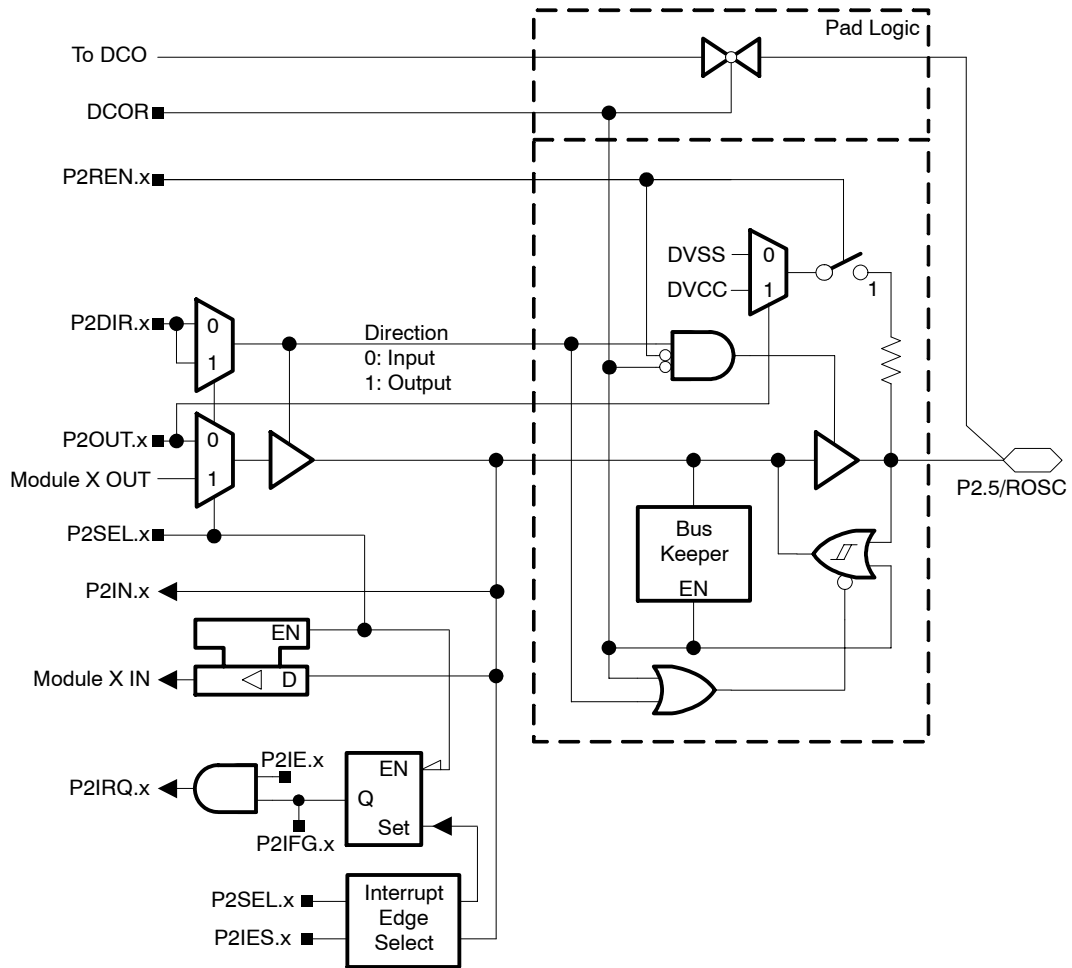

### Port P2 (P2.5) pin functions

PIN NAME (P2.x)	x	FUNCTION	CONTROL BITS / SIGNALS		
			P2DIR.x	P2SEL.x	DCOR
P2.5/R <sub>osc</sub>	5	P2.5† (I/O)	I: 0; O: 1	0	0
		N/A	0	1	0
		DV <sub>SS</sub>	1	1	0
		R <sub>osc</sub>	X	X	1

† Default after reset (PUC/POR)

NOTES: 1. N/A: Not available or not applicable

2. X: Don't care

3. Setting the ADC10AE0.y bit disables the output driver as well as the input Schmitt trigger to prevent parasitic cross currents when applying analog signals.

# MSP430x22x2, MSP430x22x4 MIXED SIGNAL MICROCONTROLLER

SLAS504D - JULY 2006 - REVISED MARCH 2010

## Port P2 pin schematic: P2.6, input/output with Schmitt trigger and crystal oscillator input

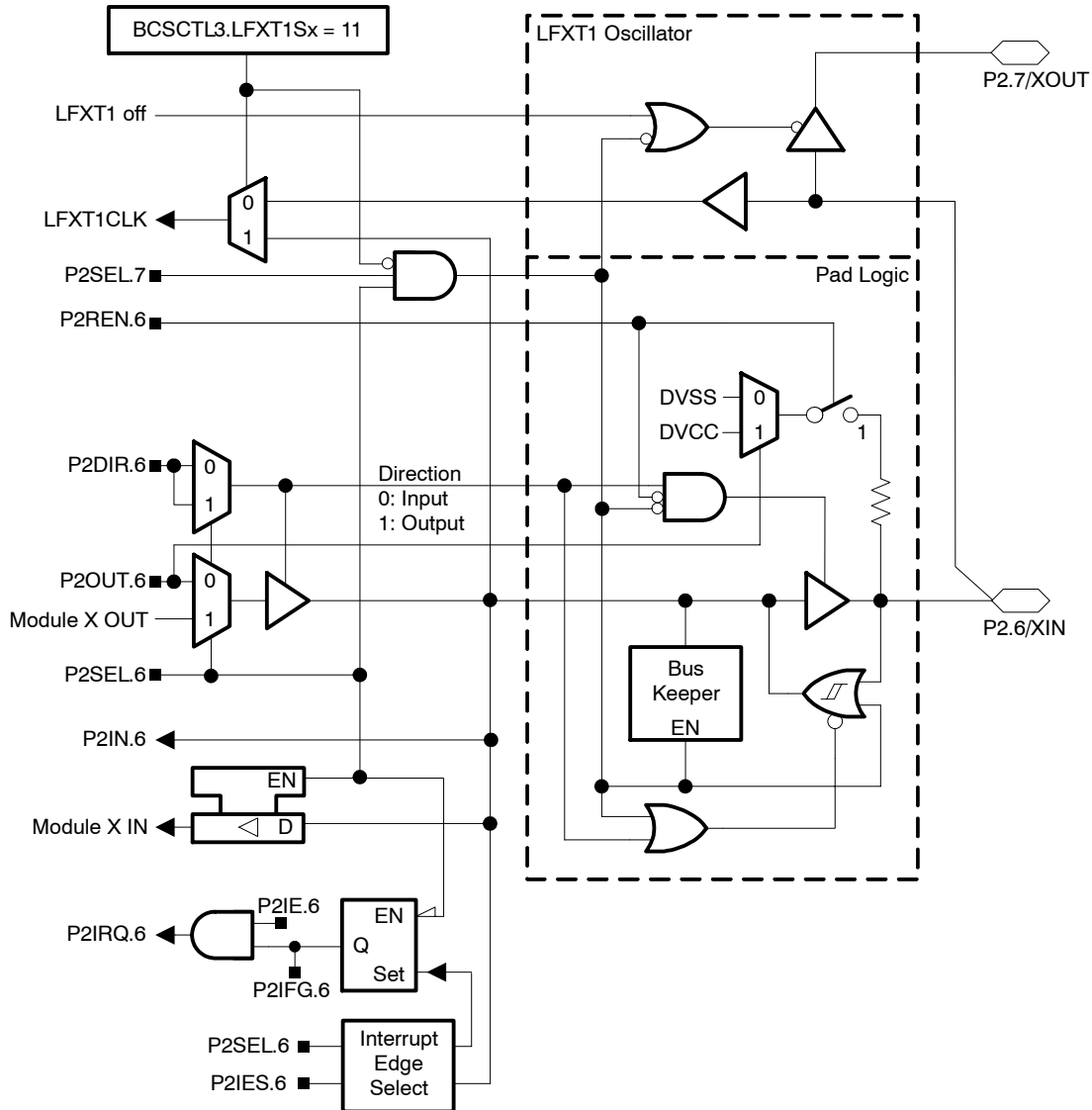

### Port P2 (P2.6) pin functions

PIN NAME (P2.x)	x	FUNCTION	CONTROL BITS / SIGNALS	
			P2DIR.x	P2SEL.x
P2.6/XIN	6	P2.6 (I/O)	I: 0; O: 1	0
		XIN†	X	1

† Default after reset (PUC/POR)

NOTES: 1. N/A: Not available or not applicable  
2. X: Don't care

## Port P2 pin schematic: P2.7, input/output with Schmitt trigger and crystal oscillator output

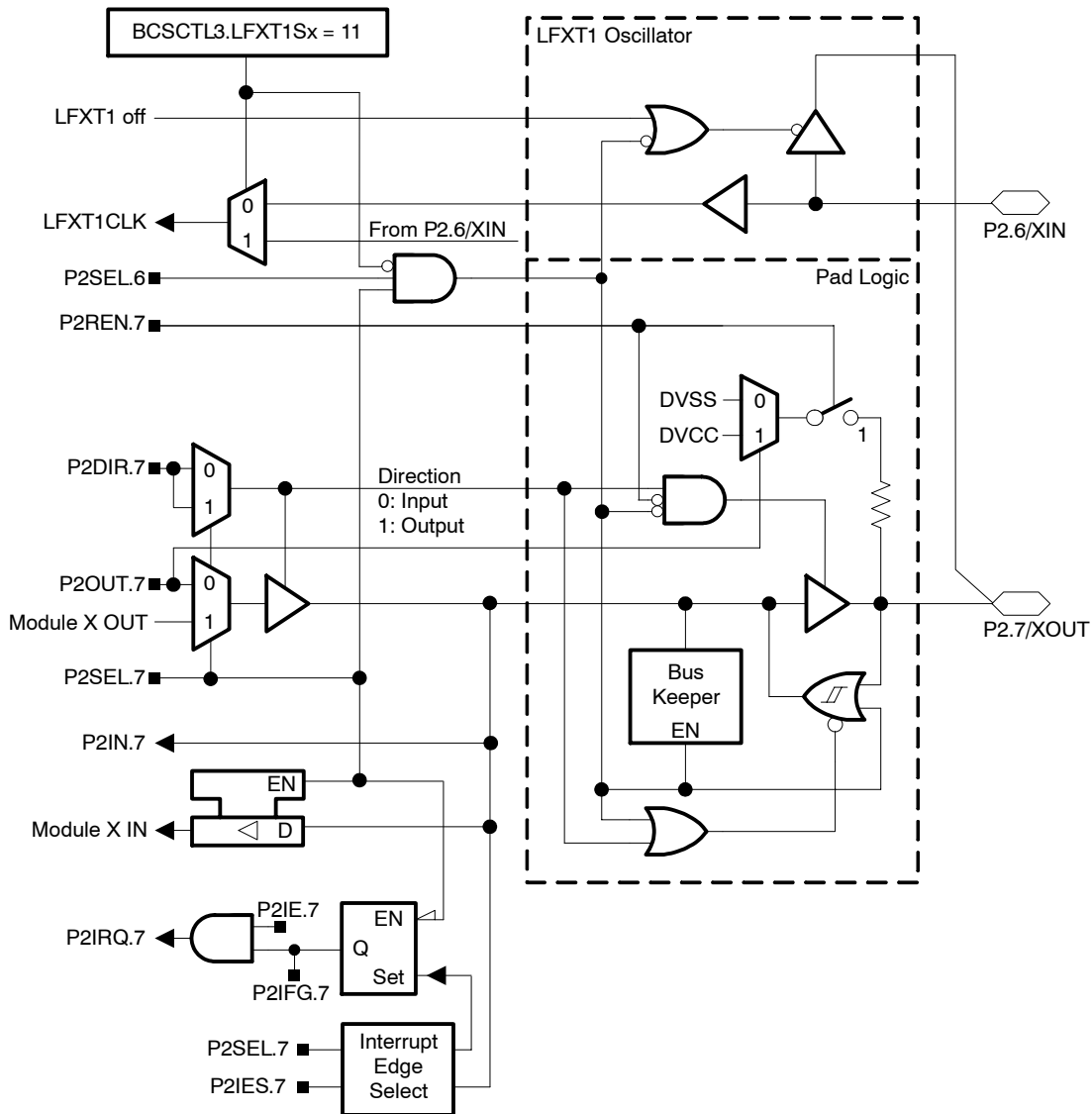

### Port P2 (P2.7) pin functions

PIN NAME (P2.x)	x	FUNCTION	CONTROL BITS / SIGNALS	
			P2DIR.x	P2SEL.x
XOUT/P2.7	7	P2.7 (I/O)	I: 0; O: 1	0
		XOUT† (see Note 3)	X	1

† Default after reset (PUC/POR)

NOTES: 1. N/A: Not available or not applicable

2. X: Don't care

3. If the pin XOUT/P2.7 is used as an input a current can flow until P2SEL.7 is cleared due to the oscillator output driver connection to this pin after reset.

# MSP430x22x2, MSP430x22x4 MIXED SIGNAL MICROCONTROLLER

SLAS504D - JULY 2006 - REVISED MARCH 2010

## Port P3 pin schematic: P3.0, input/output with Schmitt trigger

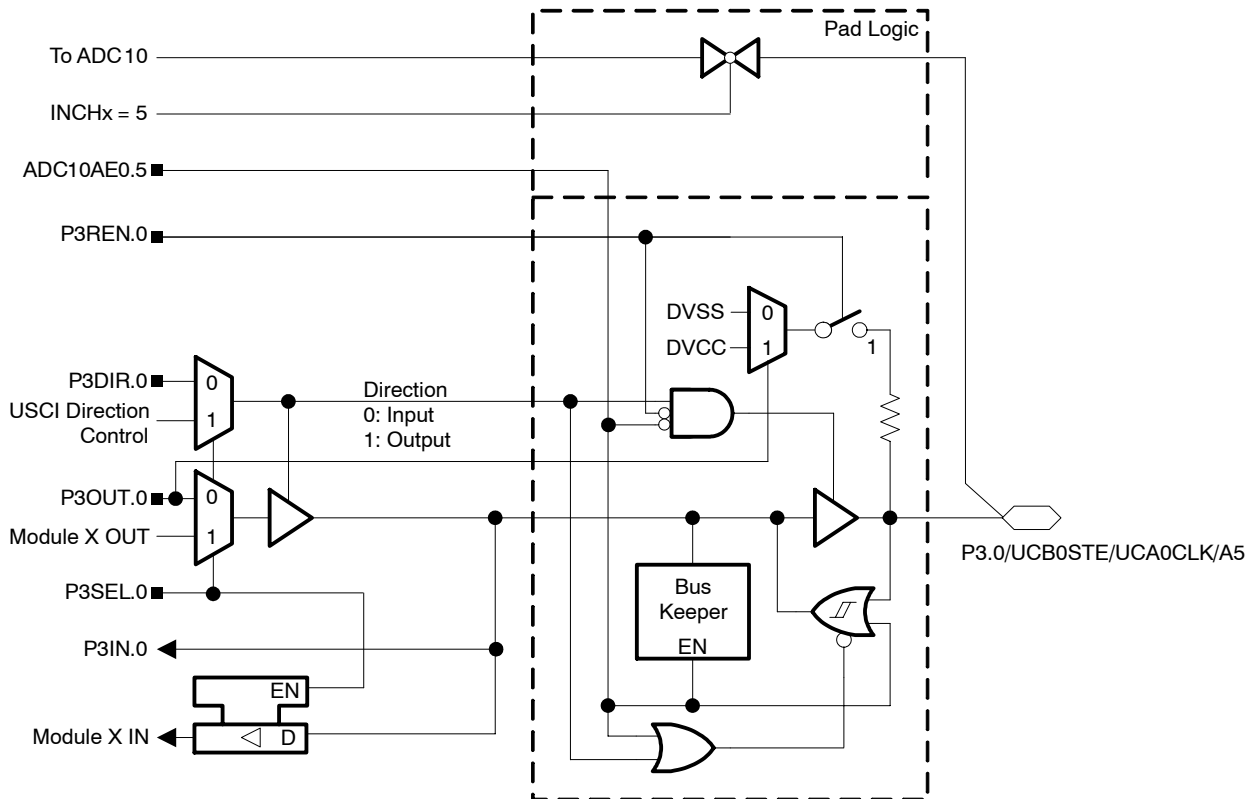

## Port P3 (P3.0) pin functions

PIN NAME (P3.x)	x	y	FUNCTION	CONTROL BITS / SIGNALS		
				P3DIR.x	P3SEL.x	ADC10AE0.y
P3.0/ UCB0STE/UCA0CLK/ A5	0	5	P3.0† (I/O)	I: 0; O: 1	0	0
			UCB0STE/UCA0CLK (see Notes 3, 4)	X	1	0
			A5 (see Note 5)	X	X	1

† Default after reset (PUC/POR)

NOTES: 1. N/A: Not available or not applicable

2. X: Don't care

3. The pin direction is controlled by the USCI module.

4. UC0CLK function takes precedence over UC1STE function. If the pin is required as UC0CLK input or output USCI1 will be forced to 3-wire SPI mode if 4-wire SPI mode is selected.

5. Setting the ADC10AE0.y bit disables the output driver as well as the input schmitt trigger to prevent parasitic cross currents when applying analog signals.

## Port P3 pin schematic: P3.1 to P3.5, input/output with Schmitt trigger

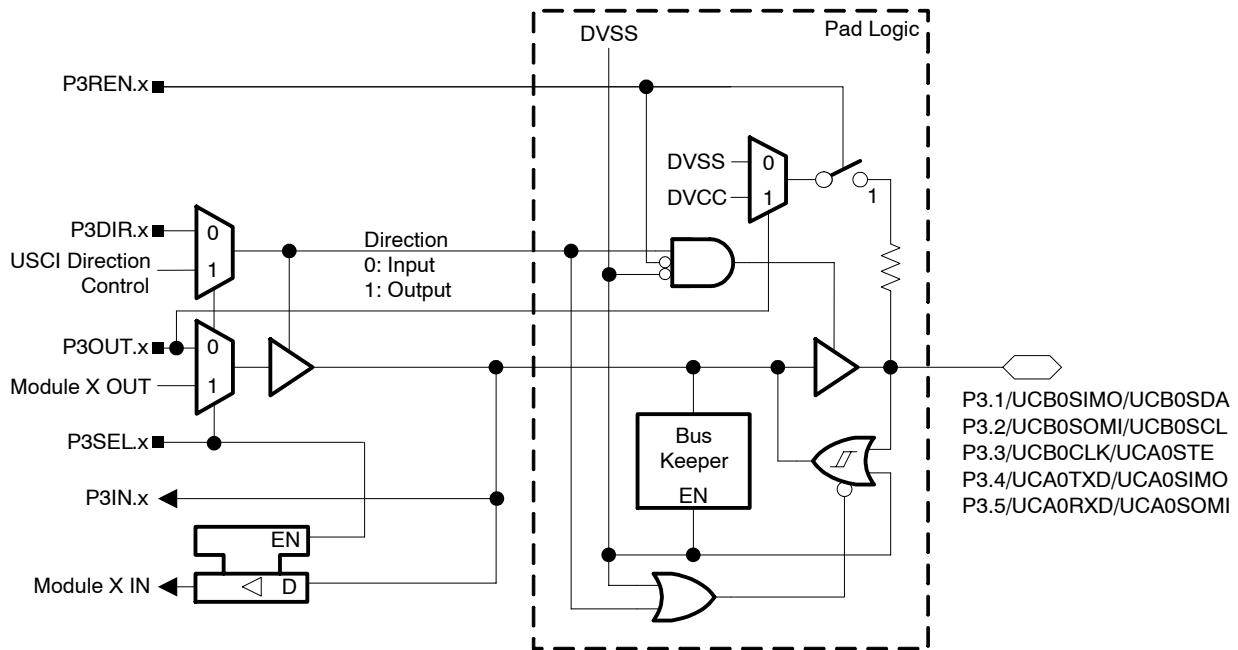

## Port P3 (P3.1 to P3.5) pin functions

PIN NAME (P3.x)	x	FUNCTION	CONTROL BITS / SIGNALS	
			P3DIR.x	P3SEL.x
P3.1/ UCB0SIMO/UCB0SDA	1	P3.1† (I/O)	I: 0; O: 1	0
		UCB0SIMO/UCB0SDA (see Note 3)	X	1
P3.2/ UCB0SOMI/UCB0SCL	2	P3.2† (I/O)	I: 0; O: 1	0
		UCB0SOMI/UCB0SCL (see Note 3)	X	1
P3.3/ UCB0CLK/UCA0STE	3	P3.3† (I/O)	I: 0; O: 1	0
		UCB0CLK/UCA0STE (see Notes 3, 4)	X	1
P3.4/ UCA0TXD/UCA0SIMO	4	P3.4† (I/O)	I: 0; O: 1	0
		UCA0TXD/UCA0SIMO (see Note 3)	X	1
P3.5/ UCA0RXD/UCA0SOMI	5	P3.5† (I/O)	I: 0; O: 1	0
		UCA0RXD/UCA0SOMI (see Note 3)	X	1

† Default after reset (PUC/POR)

- NOTES:
1. N/A: Not available or not applicable
  2. X: Don't care
  3. The pin direction is controlled by the USCI module.
  4. UCB0CLK function takes precedence over UCA0STE function. If the pin is required as UCB0CLK input or output, USCI\_A0 will be forced to 3-wire SPI mode even if 4-wire SPI mode is selected.

# MSP430x22x2, MSP430x22x4 MIXED SIGNAL MICROCONTROLLER

SLAS504D - JULY 2006 - REVISED MARCH 2010

## Port P3 pin schematic: P3.6 to P3.7, input/output with Schmitt trigger

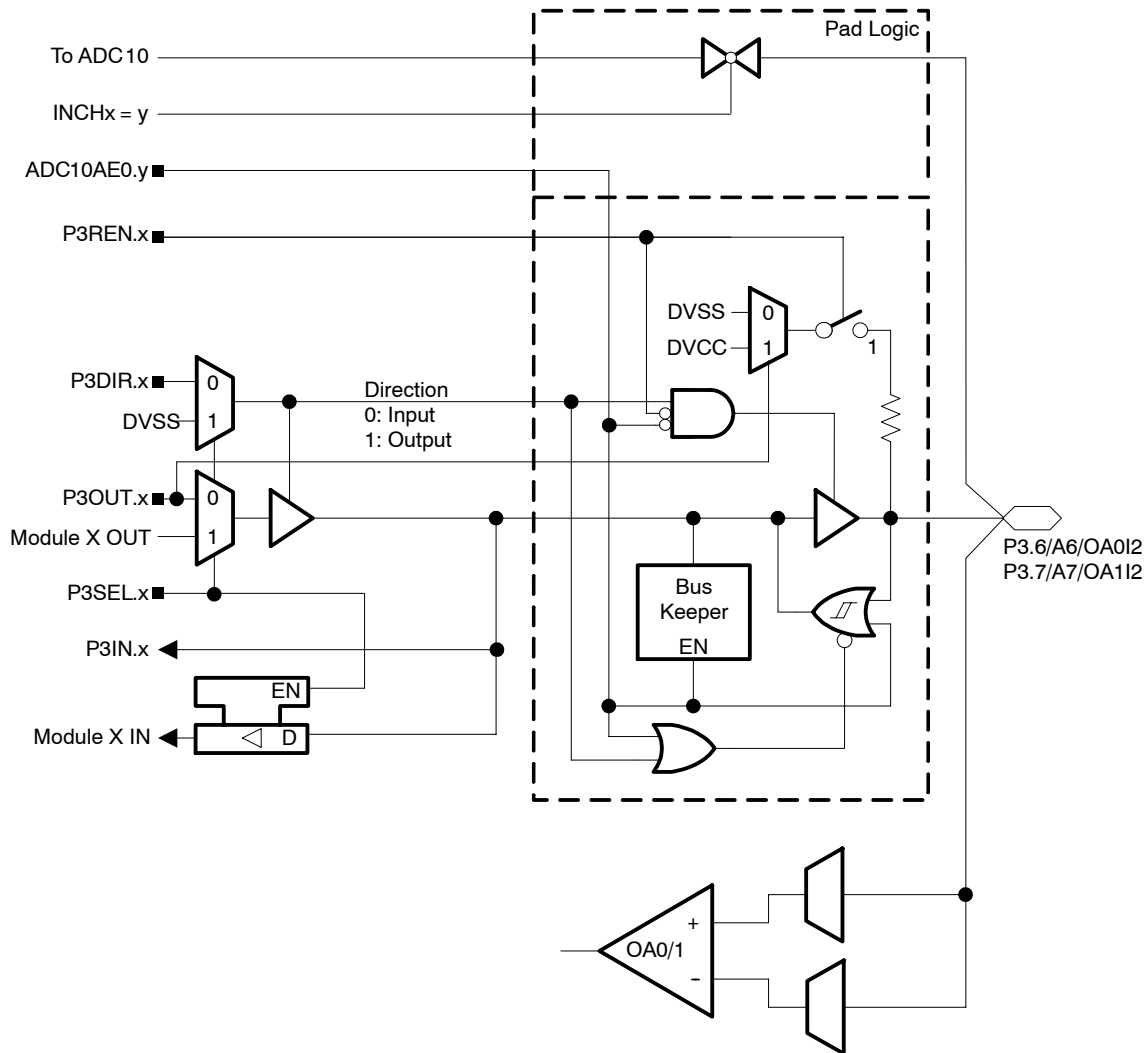

## Port P3 (P3.6, P3.7) pin functions

PIN NAME (P3.x)	x	y	FUNCTION	CONTROL BITS / SIGNALS		
				P3DIR.x	P3SEL.x	ADC10AE0.y
P3.6/A6/OA0I2	6	6	P3.6† (I/O)	I: 0; O: 1	0	0
			A6/OA0I2 (see Note 5)	X	X	1
P3.7/A7/OA1I2	7	7	P3.7† (I/O)	I: 0; O: 1	0	0
			A7/OA1I2 (see Note 5)	X	X	1

† Default after reset (PUC/POR)

NOTES: 1. N/A: Not available or not applicable

2. X: Don't care

3. The pin direction is controlled by the USC1 module.

4. UC1CLK function takes precedence over UC0STE function. If the pin is required as UC1CLK input or output USC10 will be forced to 3-wire SPI mode if 4-wire SPI mode is selected.

5. Setting the ADC10AE0.y bit disables the output driver as well as the input schmitt trigger to prevent parasitic cross currents when applying analog signals.

## Port P4 pin schematic: P4.0 to P4.2, input/output with Schmitt trigger

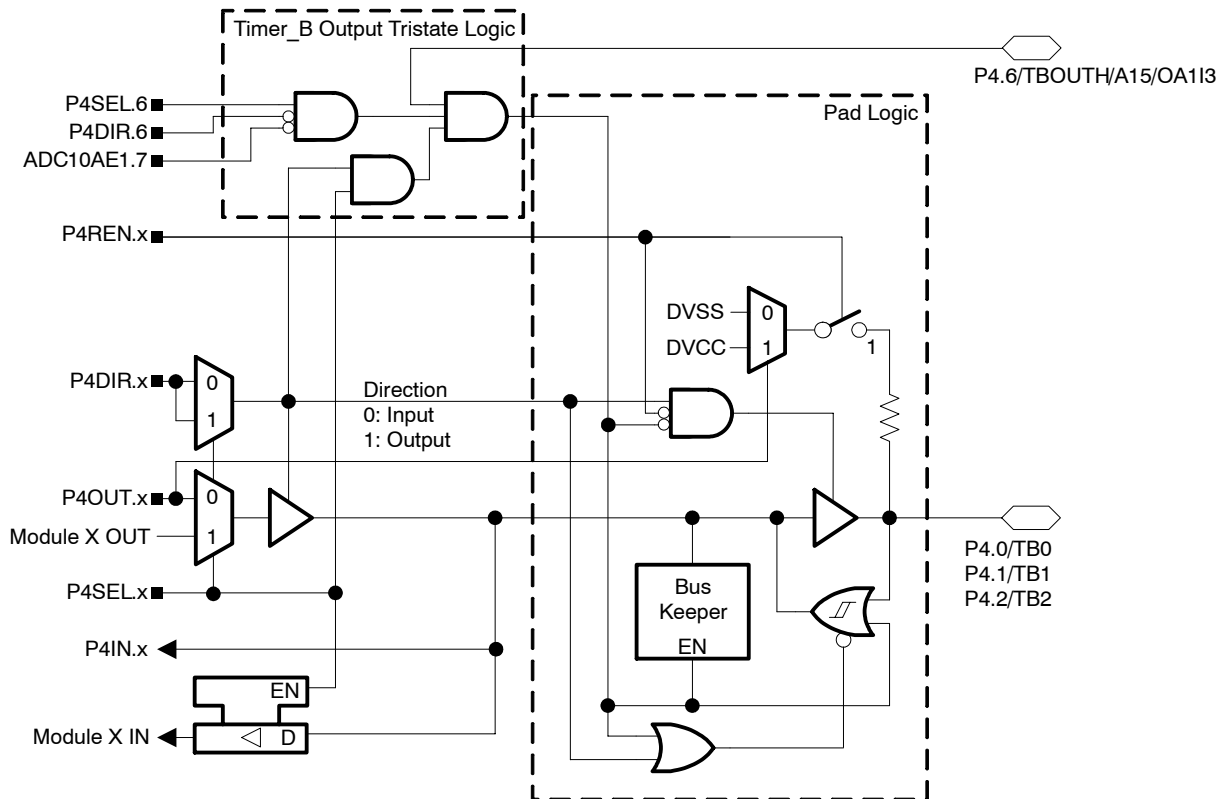

## Port P4 (P4.0 to P4.2) pin functions

PIN NAME (P4.x)	x	FUNCTION	CONTROL BITS / SIGNALS	
			P4DIR.x	P4SEL.x
P4.0/TB0	0	P4.0† (I/O)	I: 0; O: 1	0
		Timer_B3.CCI0A	0	1
		Timer_B3.TB0	1	1
P4.1/TB1	1	P4.1† (I/O)	I: 0; O: 1	0
		Timer_B3.CCI1A	0	1
		Timer_B3.TB1	1	1
P4.2/TB2	2	P4.2† (I/O)	I: 0; O: 1	0
		Timer_B3.CCI2A	0	1
		Timer_B3.TB2	1	1

† Default after reset (PUC/POR)

NOTES: 1. N/A: Not available or not applicable

# MSP430x22x2, MSP430x22x4 MIXED SIGNAL MICROCONTROLLER

SLAS504D - JULY 2006 - REVISED MARCH 2010

## Port P4 pin schematic: P4.3 to P4.4, input/output with Schmitt trigger

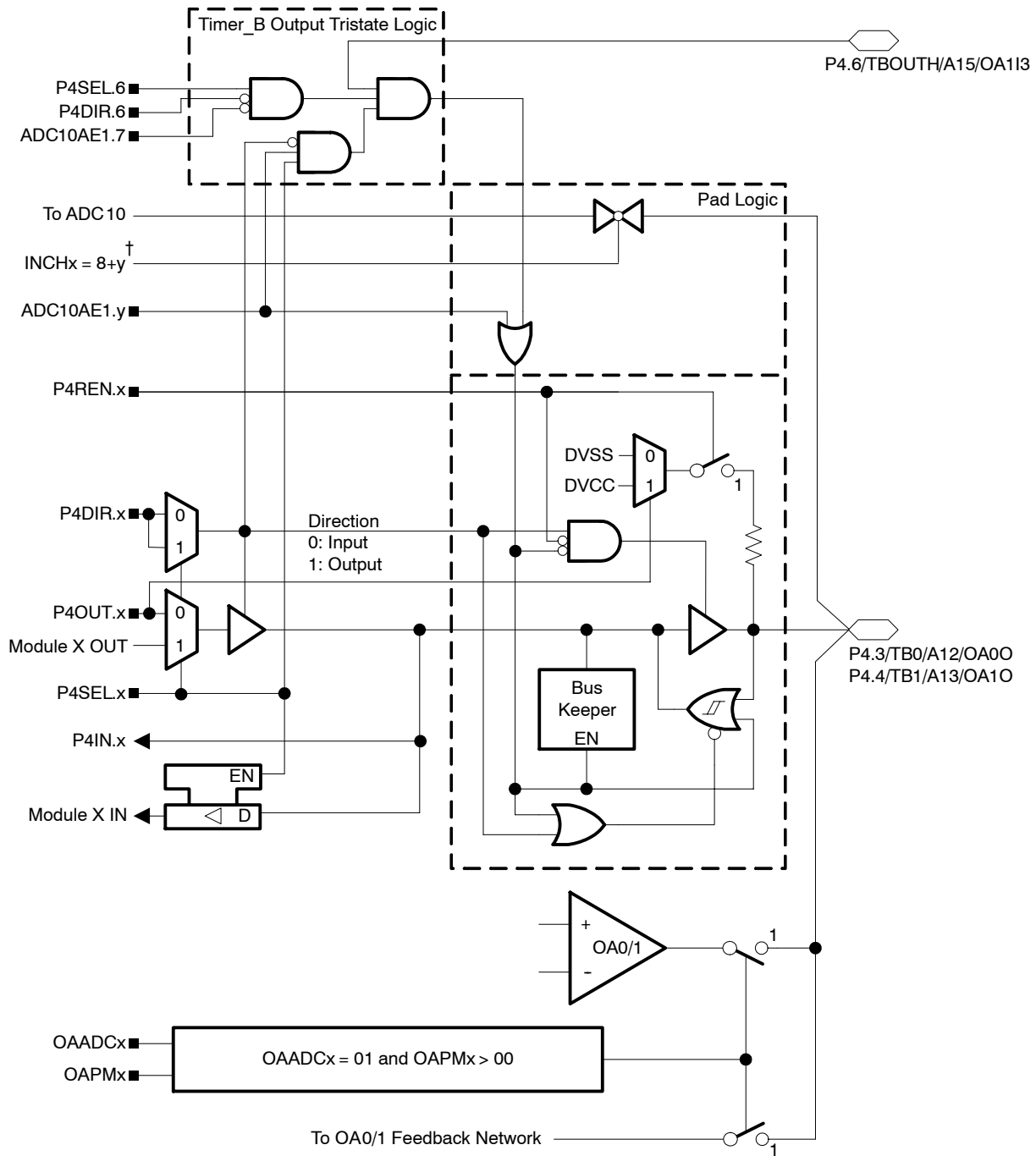

† If OAADCx = 11 and not OAFcx = 000 the ADC input A12 or A13 is internally connected to the OA0 or OA1 output respectively and the connections from the ADC and the operational amplifiers to the pad are disabled.



**Port P4 (P4.3 to P4.4) pin functions**

PIN NAME (P4.x)	x	y	FUNCTION	CONTROL BITS / SIGNALS		
				P4DIR.x	P4SEL.x	ADC10AE1.y
P4.3/TB0/A12/OA00	3	4	P4.3† (I/O)	I: 0; O: 1	0	0
			Timer_B3.CCI0B	0	1	0
			Timer_B3.TB0	1	1	0
			A12/OA00 (see Note 3)	X	X	1
P4.4/TB1/A13/OA10	4	5	P4.4† (I/O)	I: 0; O: 1	0	0
			Timer_B3.CCI1B	0	1	0
			Timer_B3.TB1	1	1	0
			A13/OA10 (see Note 3)	X	X	1

† Default after reset (PUC/POR)

- NOTES:
1. N/A: Not available or not applicable
  2. X: Don't care
  3. Setting the ADC10AE1.y bit disables the output driver as well as the input schmitt trigger to prevent parasitic cross currents when applying analog signals.

# MSP430x22x2, MSP430x22x4 MIXED SIGNAL MICROCONTROLLER

SLAS504D - JULY 2006 - REVISED MARCH 2010

## Port P4 pin schematic: P4.5, input/output with Schmitt trigger

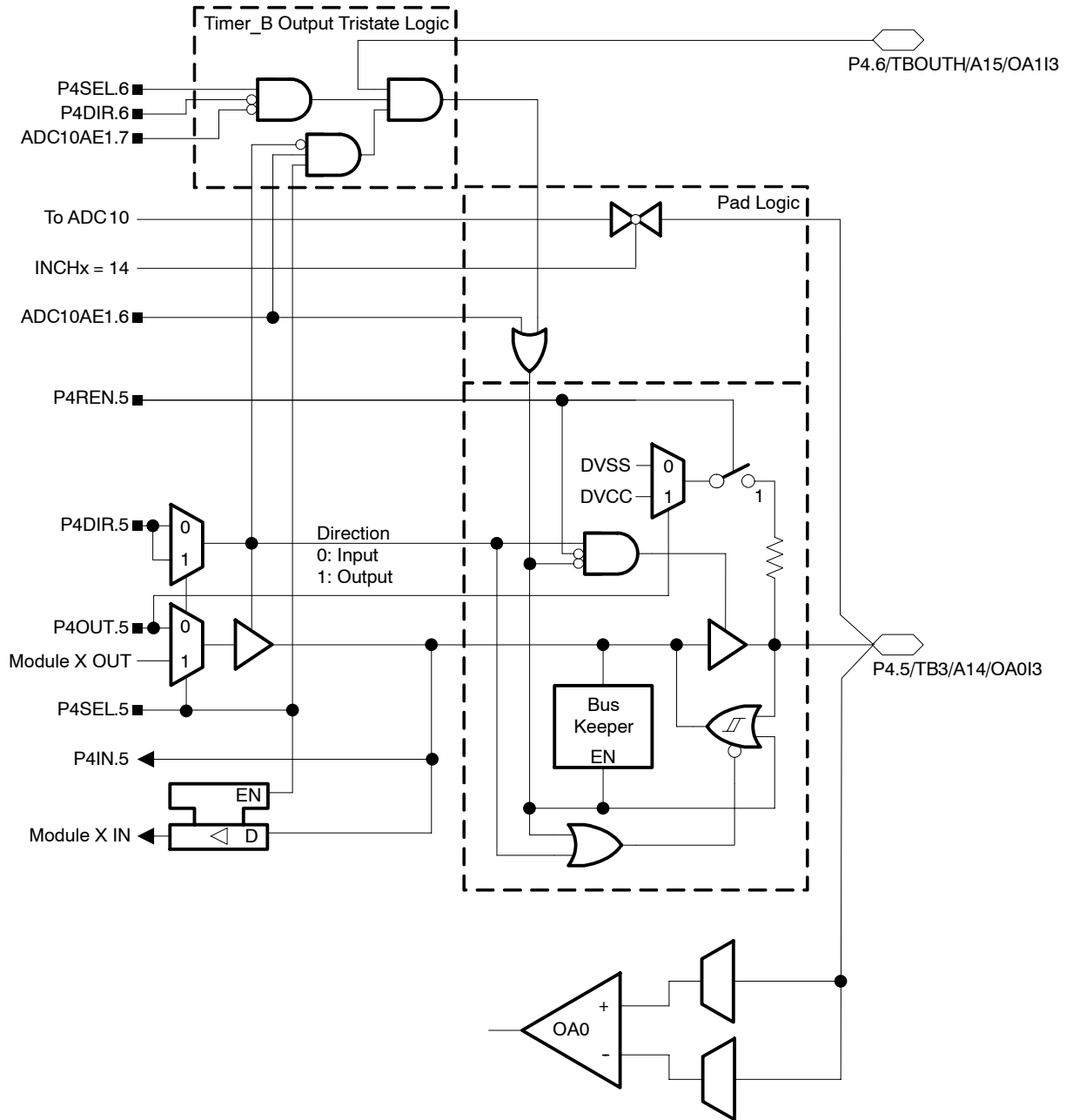

# MSP430x22x2, MSP430x22x4 MIXED SIGNAL MICROCONTROLLER

SLAS504D - JULY 2006 - REVISED MARCH 2010

## Port P4 (P4.5) pin functions

PIN NAME (P4.x)	x	y	FUNCTION	CONTROL BITS / SIGNALS		
				P4DIR.x	P4SEL.x	ADC10AE1.y
P4.5/TB3/A14/OA0I3	5	6	P4.5† (I/O)	I: 0; O: 1	0	0
			Timer_B3.TB2	1	1	0
			A14/OA0I3 (see Note 3)	X	X	1

† Default after reset (PUC/POR)

NOTES: 1. N/A: Not available or not applicable

2. X: Don't care

3. Setting the ADC10AE1.y bit disables the output driver as well as the input schmitt trigger to prevent parasitic cross currents when applying analog signals.



# MSP430x22x2, MSP430x22x4 MIXED SIGNAL MICROCONTROLLER

SLAS504D - JULY 2006 - REVISED MARCH 2010

## Port P4 pin schematic: P4.6, input/output with Schmitt trigger

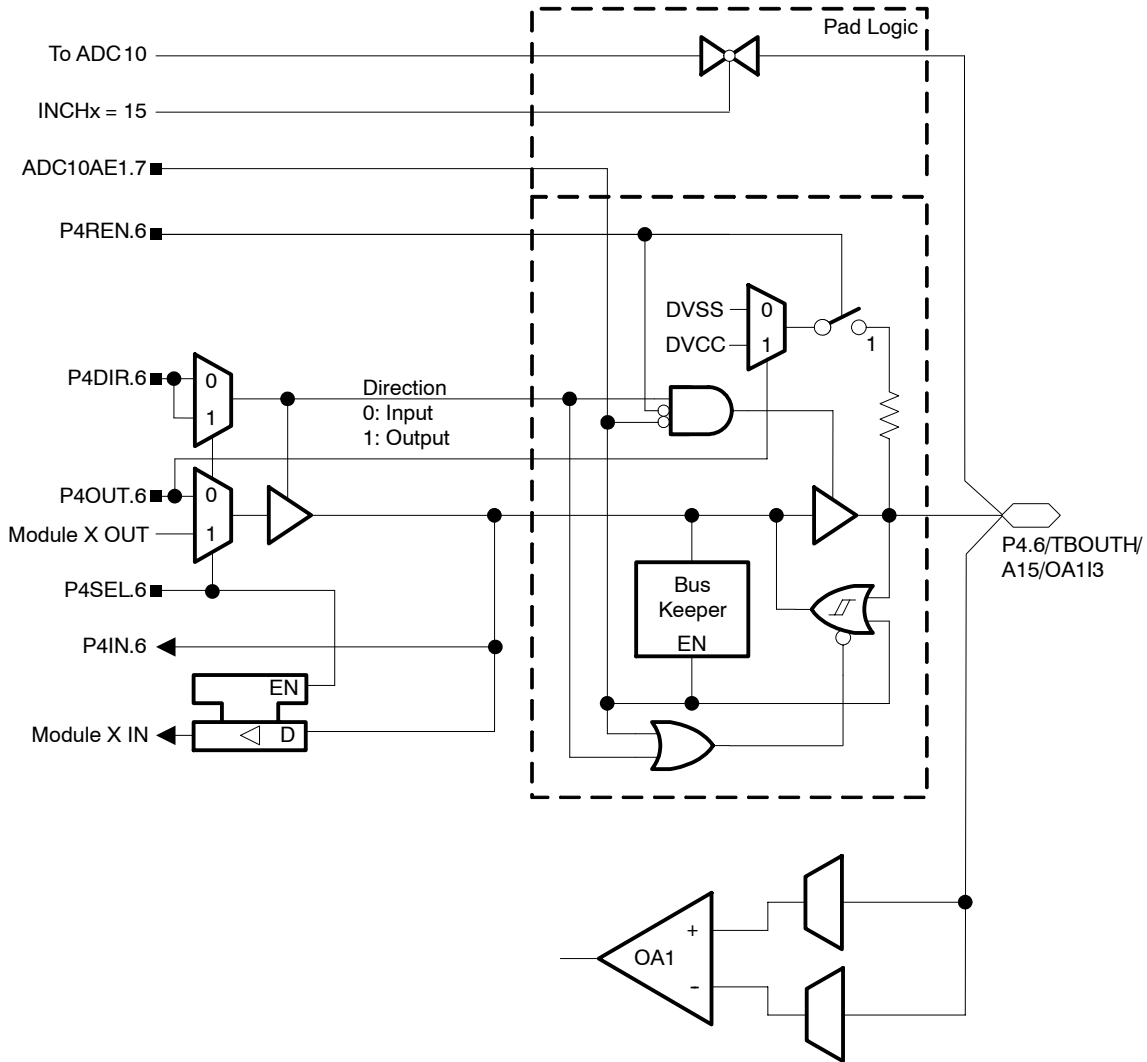

## Port P4 (P4.6) pin functions

PIN NAME (P4.x)	x	y	FUNCTION	CONTROL BITS / SIGNALS		
				P4DIR.x	P4SEL.x	ADC10AE1.y
P4.6/TBOUTH/ A15/OA1I3	6	7	P4.6† (I/O)	I: 0; O: 1	0	0
			TBOUTH	0	1	0
			DV <sub>SS</sub>	1	1	0
			A15/OA1I3 (see Note 3)	X	X	1

† Default after reset (PUC/POR)

NOTES: 1. N/A: Not available or not applicable

2. X: Don't care

3. Setting the ADC10AE1.y bit disables the output driver as well as the input schmitt trigger to prevent parasitic cross currents when applying analog signals.

Port P4 pin schematic: P4.7, input/output with Schmitt trigger

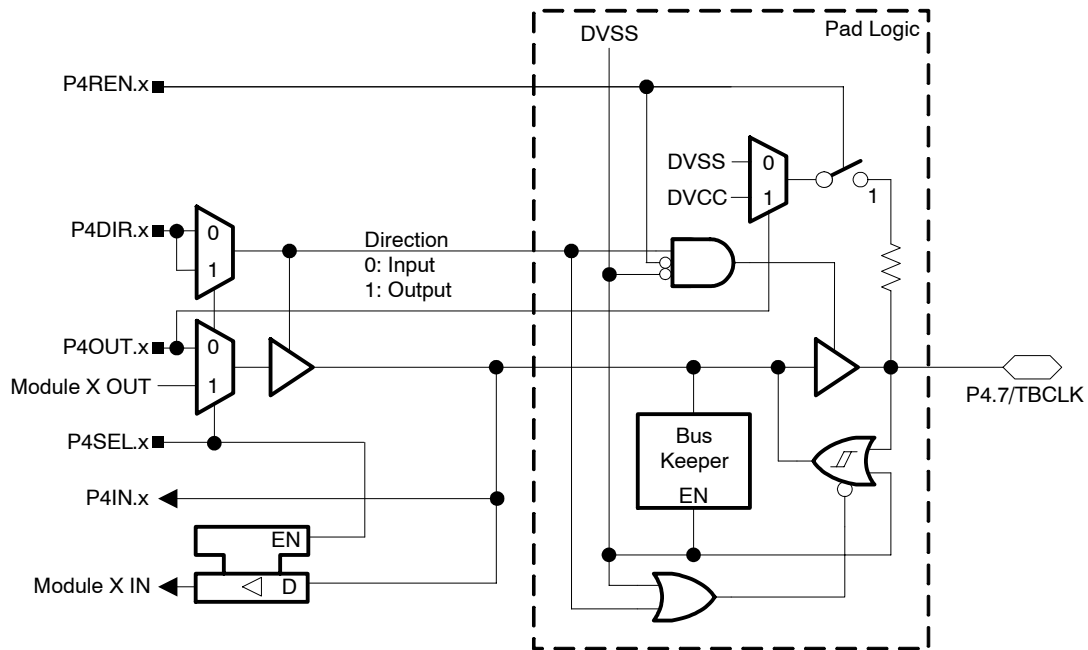

Port P4 (P4.7) pin functions

PIN NAME (P4.x)	x	FUNCTION	CONTROL BITS / SIGNALS	
			P4DIR.x	P4SEL.x
P4.7/TBCLK	7	P4.7† (I/O)	I: 0; O: 1	0
		Timer_B3.TBCLK	0	1
		DV <sub>SS</sub>	1	1

† Default after reset (PUC/POR)

NOTES: 1. N/A: Not available or not applicable  
2. X: Don't care

# MSP430x22x2, MSP430x22x4 MIXED SIGNAL MICROCONTROLLER

SLAS504D - JULY 2006 - REVISED MARCH 2010

## JTAG fuse check mode

MSP430 devices that have the fuse on the TEST terminal have a fuse check mode that tests the continuity of the fuse the first time the JTAG port is accessed after a power-on reset (POR). When activated, a fuse check current,  $I_{TF}$ , of 1 mA at 3 V, 2.5 mA at 5 V can flow from the TEST pin to ground if the fuse is not burned. Care must be taken to avoid accidentally activating the fuse check mode and increasing overall system power consumption.

When the TEST pin is again taken low after a test or programming session, the fuse check mode and sense currents are terminated.

Activation of the fuse check mode occurs with the first negative edge on the TMS pin after power up or if TMS is being held low during power up. The second positive edge on the TMS pin deactivates the fuse check mode. After deactivation, the fuse check mode remains inactive until another POR occurs. After each POR the fuse check mode has the potential to be activated.

The fuse check current only flows when the fuse check mode is active and the TMS pin is in a low state (see Figure 28). Therefore, the additional current flow can be prevented by holding the TMS pin high (default condition).

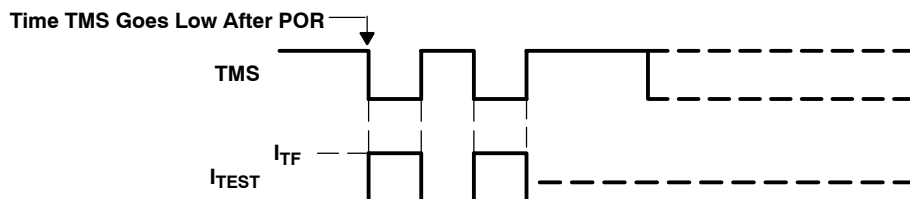

**Figure 28. Fuse Check Mode Current, MSP430F22xx**

### NOTE:

The CODE and RAM data protection is ensured if the JTAG fuse is blown and the 256-bit bootloader access key is used. Also, see the *bootstrap loader* section for more information.

**Data Sheet Revision History**

Literature Number	Summary
SLAS504	Preliminary data sheet release
SLAS504A	Production data sheet release Updated specification and added characterization graphs Updated/corrected port pin schematics
SLAS504B	Maximum low-power mode supply current limits decreased Added note concerning $f_{UCxCLK}$ to USCI SPI parameters
SLAS504C	Changed $T_{stg}$ for programmed devices from “-40°C to 105°C” to “-55°C to 105°C” (page 23) Added Development Tool Support section (page 2)
SLAS504D	Corrected pin names in “Port P3 pin schematic: P3.0” and “Port P3 (P3.0) pin functions” (page 68) Corrected pin names in “Port P3 pin schematic: P3.1 to P3.5” and “Port P3 (P3.1 to P3.5) pin functions” (page 69) Corrected signal names in “Port P2 pin schematic: P2.5, input/output” (page 65) (D1) Corrected values in “x” column in “Port P3 (P3.1 to P3.5) pin functions” (page 69) (D2)

NOTE: Page and figure numbers apply to the specific document revision and may differ in other revisions.

**PACKAGING INFORMATION**

Orderable Device	Status <sup>(1)</sup>	Package Type	Package Drawing	Pins	Package Qty	Eco Plan <sup>(2)</sup>	Lead/Ball Finish	MSL Peak Temp <sup>(3)</sup>
MSP430F2232IDA	ACTIVE	TSSOP	DA	38	40	Green (RoHS & no Sb/Br)	CU NIPDAU	Level-2-260C-1 YEAR
MSP430F2232IDAR	ACTIVE	TSSOP	DA	38	2000	Green (RoHS & no Sb/Br)	CU NIPDAU	Level-2-260C-1 YEAR
MSP430F2232IRHAR	ACTIVE	VQFN	RHA	40	2500	Green (RoHS & no Sb/Br)	CU NIPDAU	Level-3-260C-168 HR
MSP430F2232IRHAT	ACTIVE	VQFN	RHA	40	250	Green (RoHS & no Sb/Br)	CU NIPDAU	Level-3-260C-168 HR
MSP430F2232TDA	ACTIVE	TSSOP	DA	38	40	Green (RoHS & no Sb/Br)	CU NIPDAU	Level-2-260C-1 YEAR
MSP430F2232TDAR	ACTIVE	TSSOP	DA	38	2000	Green (RoHS & no Sb/Br)	CU NIPDAU	Level-2-260C-1 YEAR
MSP430F2232TRHAR	ACTIVE	VQFN	RHA	40	2500	Green (RoHS & no Sb/Br)	CU NIPDAU	Level-3-260C-168 HR
MSP430F2232TRHAT	ACTIVE	VQFN	RHA	40	250	Green (RoHS & no Sb/Br)	CU NIPDAU	Level-3-260C-168 HR
MSP430F2234IDA	ACTIVE	TSSOP	DA	38	40	Green (RoHS & no Sb/Br)	CU NIPDAU	Level-2-260C-1 YEAR
MSP430F2234IDAR	ACTIVE	TSSOP	DA	38	2000	Green (RoHS & no Sb/Br)	CU NIPDAU	Level-2-260C-1 YEAR
MSP430F2234IRHAR	ACTIVE	VQFN	RHA	40	2500	Green (RoHS & no Sb/Br)	CU NIPDAU	Level-3-260C-168 HR
MSP430F2234IRHAT	ACTIVE	VQFN	RHA	40	250	Green (RoHS & no Sb/Br)	CU NIPDAU	Level-3-260C-168 HR
MSP430F2234TDA	ACTIVE	TSSOP	DA	38	40	Green (RoHS & no Sb/Br)	CU NIPDAU	Level-2-260C-1 YEAR
MSP430F2234TDAR	ACTIVE	TSSOP	DA	38	2000	Green (RoHS & no Sb/Br)	CU NIPDAU	Level-2-260C-1 YEAR
MSP430F2234TRHAR	ACTIVE	VQFN	RHA	40	2500	Green (RoHS & no Sb/Br)	CU NIPDAU	Level-3-260C-168 HR
MSP430F2234TRHAT	ACTIVE	VQFN	RHA	40	250	Green (RoHS & no Sb/Br)	CU NIPDAU	Level-3-260C-168 HR
MSP430F2252IDA	ACTIVE	TSSOP	DA	38	40	Green (RoHS & no Sb/Br)	CU NIPDAU	Level-2-260C-1 YEAR
MSP430F2252IDAR	ACTIVE	TSSOP	DA	38	2000	Green (RoHS & no Sb/Br)	CU NIPDAU	Level-2-260C-1 YEAR
MSP430F2252IRHAR	ACTIVE	VQFN	RHA	40	2500	Green (RoHS & no Sb/Br)	CU NIPDAU	Level-3-260C-168 HR
MSP430F2252IRHAT	ACTIVE	VQFN	RHA	40	250	Green (RoHS & no Sb/Br)	CU NIPDAU	Level-3-260C-168 HR
MSP430F2252TDA	ACTIVE	TSSOP	DA	38	40	Green (RoHS & no Sb/Br)	CU NIPDAU	Level-2-260C-1 YEAR
MSP430F2252TDAR	ACTIVE	TSSOP	DA	38	2000	Green (RoHS & no Sb/Br)	CU NIPDAU	Level-2-260C-1 YEAR
MSP430F2252TRHAR	ACTIVE	VQFN	RHA	40	2500	Green (RoHS & no Sb/Br)	CU NIPDAU	Level-3-260C-168 HR
MSP430F2252TRHAT	ACTIVE	VQFN	RHA	40	250	Green (RoHS & no Sb/Br)	CU NIPDAU	Level-3-260C-168 HR
MSP430F2254IDA	ACTIVE	TSSOP	DA	38	40	Green (RoHS & no Sb/Br)	CU NIPDAU	Level-2-260C-1 YEAR



Orderable Device	Status <sup>(1)</sup>	Package Type	Package Drawing	Pins	Package Qty	Eco Plan <sup>(2)</sup>	Lead/Ball Finish	MSL Peak Temp <sup>(3)</sup>
MSP430F2254IDAR	ACTIVE	TSSOP	DA	38	2000	Green (RoHS & no Sb/Br)	CU NIPDAU	Level-2-260C-1 YEAR
MSP430F2254IRHAR	ACTIVE	VQFN	RHA	40	2500	Green (RoHS & no Sb/Br)	CU NIPDAU	Level-3-260C-168 HR
MSP430F2254IRHAT	ACTIVE	VQFN	RHA	40	250	Green (RoHS & no Sb/Br)	CU NIPDAU	Level-3-260C-168 HR
MSP430F2254TDA	ACTIVE	TSSOP	DA	38	40	Green (RoHS & no Sb/Br)	CU NIPDAU	Level-2-260C-1 YEAR
MSP430F2254TDAR	ACTIVE	TSSOP	DA	38	2000	Green (RoHS & no Sb/Br)	CU NIPDAU	Level-2-260C-1 YEAR
MSP430F2254TRHAR	ACTIVE	VQFN	RHA	40	2500	Green (RoHS & no Sb/Br)	CU NIPDAU	Level-3-260C-168 HR
MSP430F2254TRHAT	ACTIVE	VQFN	RHA	40	250	Green (RoHS & no Sb/Br)	CU NIPDAU	Level-3-260C-168 HR
MSP430F2272IDA	ACTIVE	TSSOP	DA	38	40	Green (RoHS & no Sb/Br)	CU NIPDAU	Level-2-260C-1 YEAR
MSP430F2272IDAR	ACTIVE	TSSOP	DA	38	2000	Green (RoHS & no Sb/Br)	CU NIPDAU	Level-2-260C-1 YEAR
MSP430F2272IRHAR	ACTIVE	VQFN	RHA	40	2500	Green (RoHS & no Sb/Br)	CU NIPDAU	Level-3-260C-168 HR
MSP430F2272IRHAT	ACTIVE	VQFN	RHA	40	250	Green (RoHS & no Sb/Br)	CU NIPDAU	Level-3-260C-168 HR
MSP430F2272TDA	ACTIVE	TSSOP	DA	38	40	Green (RoHS & no Sb/Br)	CU NIPDAU	Level-2-260C-1 YEAR
MSP430F2272TDAR	ACTIVE	TSSOP	DA	38	2000	Green (RoHS & no Sb/Br)	CU NIPDAU	Level-2-260C-1 YEAR
MSP430F2272TRHAR	ACTIVE	VQFN	RHA	40	2500	Green (RoHS & no Sb/Br)	CU NIPDAU	Level-3-260C-168 HR
MSP430F2272TRHAT	ACTIVE	VQFN	RHA	40	250	Green (RoHS & no Sb/Br)	CU NIPDAU	Level-3-260C-168 HR
MSP430F2274IDA	ACTIVE	TSSOP	DA	38	40	Green (RoHS & no Sb/Br)	CU NIPDAU	Level-2-260C-1 YEAR
MSP430F2274IDAR	ACTIVE	TSSOP	DA	38	2000	Green (RoHS & no Sb/Br)	CU NIPDAU	Level-2-260C-1 YEAR
MSP430F2274IRHAR	ACTIVE	VQFN	RHA	40	2500	Green (RoHS & no Sb/Br)	CU NIPDAU	Level-3-260C-168 HR
MSP430F2274IRHAT	ACTIVE	VQFN	RHA	40	250	Green (RoHS & no Sb/Br)	CU NIPDAU	Level-3-260C-168 HR
MSP430F2274TDA	ACTIVE	TSSOP	DA	38	40	Green (RoHS & no Sb/Br)	CU NIPDAU	Level-2-260C-1 YEAR
MSP430F2274TDAR	ACTIVE	TSSOP	DA	38	2000	Green (RoHS & no Sb/Br)	CU NIPDAU	Level-2-260C-1 YEAR
MSP430F2274TRHAR	ACTIVE	VQFN	RHA	40	2500	Green (RoHS & no Sb/Br)	CU NIPDAU	Level-3-260C-168 HR
MSP430F2274TRHAT	ACTIVE	VQFN	RHA	40	250	Green (RoHS & no Sb/Br)	CU NIPDAU	Level-3-260C-168 HR

<sup>(1)</sup> The marketing status values are defined as follows:

**ACTIVE:** Product device recommended for new designs.

**LIFEBUY:** TI has announced that the device will be discontinued, and a lifetime-buy period is in effect.

**NRND:** Not recommended for new designs. Device is in production to support existing customers, but TI does not recommend using this part in a new design.

**PREVIEW:** Device has been announced but is not in production. Samples may or may not be available.

**OBSELETE:** TI has discontinued the production of the device.

<sup>(2)</sup> Eco Plan - The planned eco-friendly classification: Pb-Free (RoHS), Pb-Free (RoHS Exempt), or Green (RoHS & no Sb/Br) - please check <http://www.ti.com/productcontent> for the latest availability information and additional product content details.

**TBD:** The Pb-Free/Green conversion plan has not been defined.

**Pb-Free (RoHS):** TI's terms "Lead-Free" or "Pb-Free" mean semiconductor products that are compatible with the current RoHS requirements for all 6 substances, including the requirement that lead not exceed 0.1% by weight in homogeneous materials. Where designed to be soldered at high temperatures, TI Pb-Free products are suitable for use in specified lead-free processes.

**Pb-Free (RoHS Exempt):** This component has a RoHS exemption for either 1) lead-based flip-chip solder bumps used between the die and package, or 2) lead-based die adhesive used between the die and leadframe. The component is otherwise considered Pb-Free (RoHS compatible) as defined above.

**Green (RoHS & no Sb/Br):** TI defines "Green" to mean Pb-Free (RoHS compatible), and free of Bromine (Br) and Antimony (Sb) based flame retardants (Br or Sb do not exceed 0.1% by weight in homogeneous material)

<sup>(3)</sup> MSL, Peak Temp. -- The Moisture Sensitivity Level rating according to the JEDEC industry standard classifications, and peak solder temperature.

**Important Information and Disclaimer:**The information provided on this page represents TI's knowledge and belief as of the date that it is provided. TI bases its knowledge and belief on information provided by third parties, and makes no representation or warranty as to the accuracy of such information. Efforts are underway to better integrate information from third parties. TI has taken and continues to take reasonable steps to provide representative and accurate information but may not have conducted destructive testing or chemical analysis on incoming materials and chemicals. TI and TI suppliers consider certain information to be proprietary, and thus CAS numbers and other limited information may not be available for release.

In no event shall TI's liability arising out of such information exceed the total purchase price of the TI part(s) at issue in this document sold by TI to Customer on an annual basis.

**OTHER QUALIFIED VERSIONS OF MSP430F2274 :**

- Enhanced Product: [MSP430F2274-EP](#)

NOTE: Qualified Version Definitions:

- Enhanced Product - Supports Defense, Aerospace and Medical Applications

**TAPE AND REEL INFORMATION**

**QUADRANT ASSIGNMENTS FOR PIN 1 ORIENTATION IN TAPE**

\*All dimensions are nominal

Device	Package Type	Package Drawing	Pins	SPQ	Reel Diameter (mm)	Reel Width W1 (mm)	A0 (mm)	B0 (mm)	K0 (mm)	P1 (mm)	W (mm)	Pin1 Quadrant
MSP430F2232IDAR	TSSOP	DA	38	2000	330.0	24.4	8.6	13.0	1.8	12.0	24.0	Q1
MSP430F2252IDAR	TSSOP	DA	38	2000	330.0	24.4	8.6	13.0	1.8	12.0	24.0	Q1
MSP430F2254IDAR	TSSOP	DA	38	2000	330.0	24.4	8.6	13.0	1.8	12.0	24.0	Q1
MSP430F2272IDAR	TSSOP	DA	38	2000	330.0	24.4	8.6	13.0	1.8	12.0	24.0	Q1
MSP430F2274IDAR	TSSOP	DA	38	2000	330.0	24.4	8.6	13.0	1.8	12.0	24.0	Q1

**TAPE AND REEL BOX DIMENSIONS**

\*All dimensions are nominal

Device	Package Type	Package Drawing	Pins	SPQ	Length (mm)	Width (mm)	Height (mm)
MSP430F2232IDAR	TSSOP	DA	38	2000	346.0	346.0	41.0
MSP430F2252IDAR	TSSOP	DA	38	2000	346.0	346.0	41.0
MSP430F2254IDAR	TSSOP	DA	38	2000	346.0	346.0	41.0
MSP430F2272IDAR	TSSOP	DA	38	2000	346.0	346.0	41.0
MSP430F2274IDAR	TSSOP	DA	38	2000	346.0	346.0	41.0

RHA (S-PVQFN-N40)

PLASTIC QUAD FLATPACK NO-LEAD

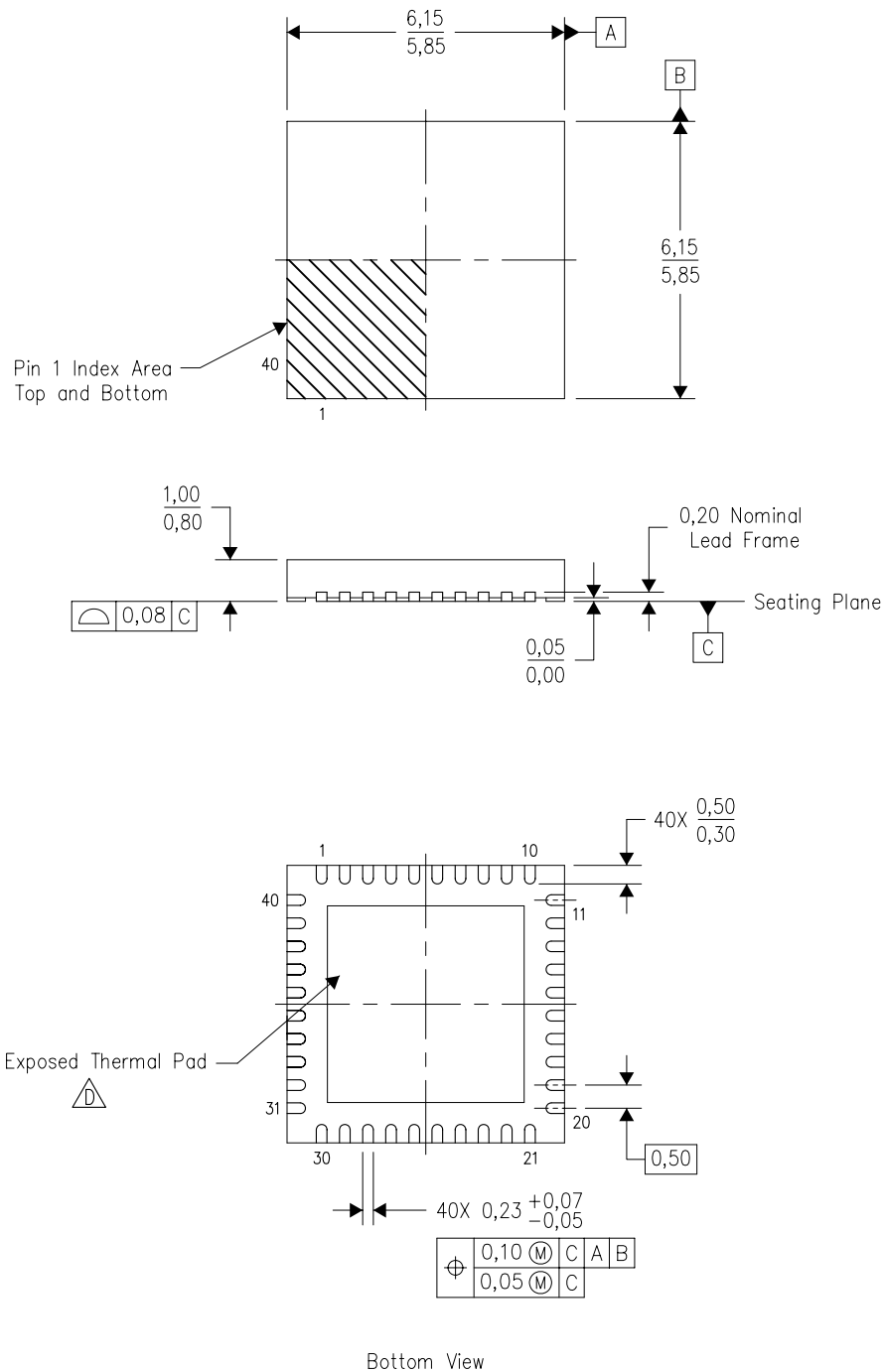

4204276/D 08/10

- NOTES:
- A. All linear dimensions are in millimeters. Dimensioning and tolerancing per ASME Y14.5M-1994.
  - B. This drawing is subject to change without notice.
  - C. QFN (Quad Flatpack No-Lead) Package configuration.
  -  The package thermal pad must be soldered to the board for thermal and mechanical performance. See the Product Data Sheet for details regarding the exposed thermal pad dimensions.
  - E. Package complies to JEDEC MO-220 variation VJJD-2.

## THERMAL PAD MECHANICAL DATA

RHA (S-PVQFN-N40)

PLASTIC QUAD FLATPACK NO-LEAD

### THERMAL INFORMATION

This package incorporates an exposed thermal pad that is designed to be attached directly to an external heatsink. The thermal pad must be soldered directly to the printed circuit board (PCB). After soldering, the PCB can be used as a heatsink. In addition, through the use of thermal vias, the thermal pad can be attached directly to the appropriate copper plane shown in the electrical schematic for the device, or alternatively, can be attached to a special heatsink structure designed into the PCB. This design optimizes the heat transfer from the integrated circuit (IC).

For information on the Quad Flatpack No-Lead (QFN) package and its advantages, refer to Application Report, QFN/SON PCB Attachment, Texas Instruments Literature No. SLUA271. This document is available at [www.ti.com](http://www.ti.com).

The exposed thermal pad dimensions for this package are shown in the following illustration.

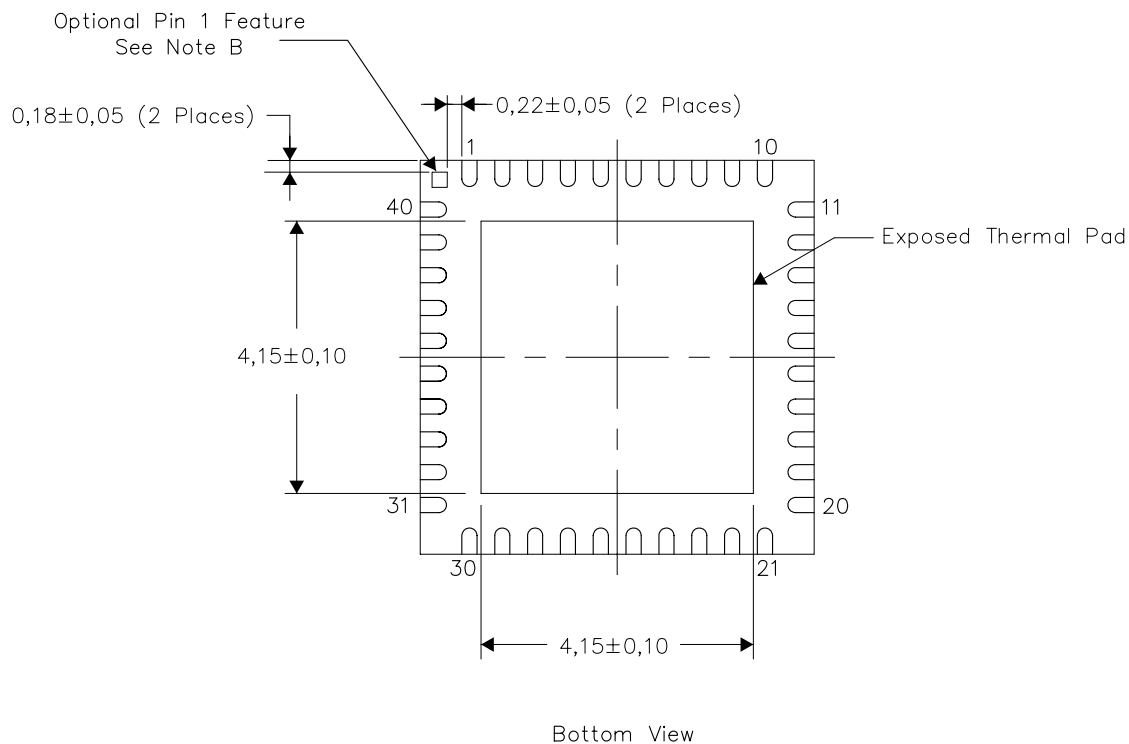

Exposed Thermal Pad Dimensions

4206355-2/L 08/10

- NOTES:
- A. All linear dimensions are in millimeters
  - B. The Pin 1 Identification mark is an optional feature that may be present on some devices  
In addition, this Pin 1 feature if present is electrically connected to the center thermal pad and therefore should be considered when routing the board layout.

RHA (S-PVQFN-N40)

PLASTIC QUAD FLATPACK NO-LEAD

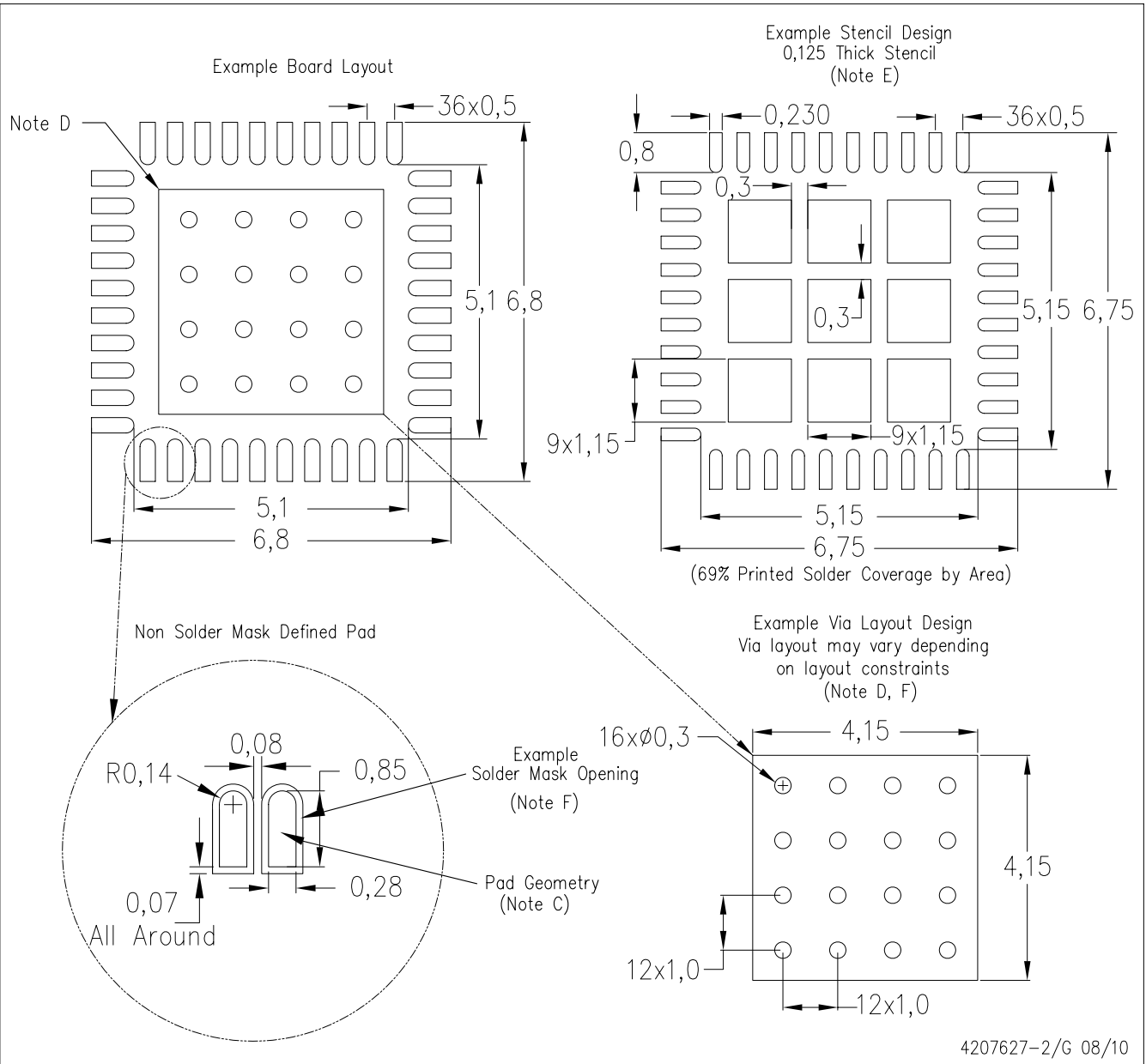

- NOTES:
- A. All linear dimensions are in millimeters.
  - B. This drawing is subject to change without notice.
  - C. Publication IPC-7351 is recommended for alternate designs.
  - D. This package is designed to be soldered to a thermal pad on the board. Refer to Application Note, Quad Flat-Pack Packages, Texas Instruments Literature No. SLUA271, and also the Product Data Sheets for specific thermal information, via requirements, and recommended board layout. These documents are available at [www.ti.com](http://www.ti.com) <<http://www.ti.com>>.
  - E. Laser cutting apertures with trapezoidal walls and also rounding corners will offer better paste release. Customers should contact their board assembly site for stencil design recommendations. Refer to IPC 7525 for stencil design considerations.
  - F. Customers should contact their board fabrication site for recommended solder mask tolerances and via tenting recommendations for vias placed in the thermal pad.

DA (R-PDSO-G\*\*)   
 38 PIN SHOWN

PLASTIC SMALL-OUTLINE PACKAGE



- NOTES:
- A. All linear dimensions are in millimeters.
  - B. This drawing is subject to change without notice.
  - C. Body dimensions do not include mold flash or protrusion. Mold flash and protrusion shall not exceed 0.15 per side.
  - ⚠** Falls within JEDEC MO-153, except 30 pin body length.



DA (R-PDSO-G38)

PLASTIC SMALL OUTLINE

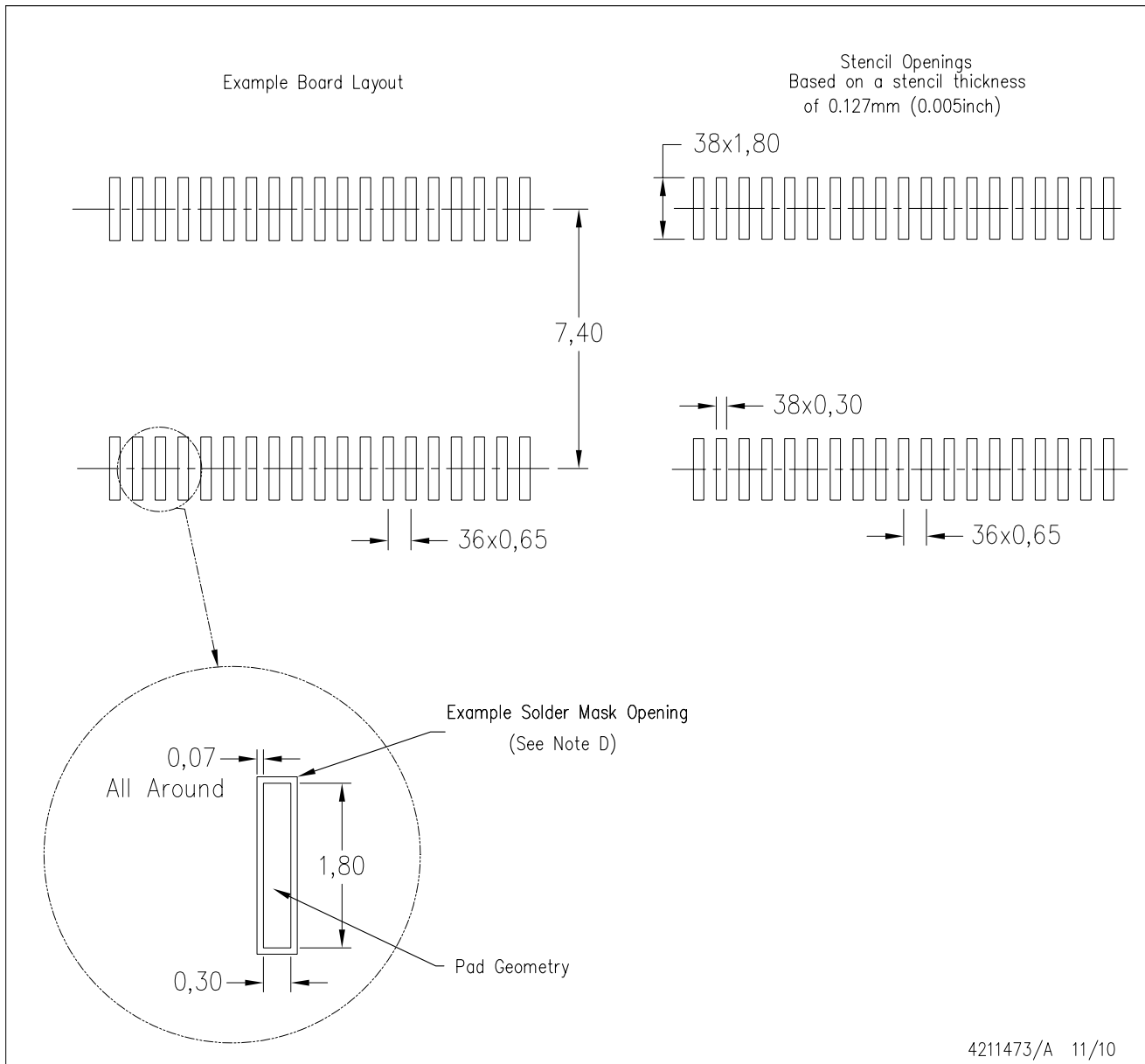

- NOTES:
- A. All linear dimensions are in millimeters.
  - B. This drawing is subject to change without notice.
  - C. Laser cutting apertures with trapezoidal walls and also rounding corners will offer better paste release. Customers should contact their board assembly site for stencil design recommendations. Example stencil design based on a 50% volumetric metal load solder paste. Refer to IPC-7525 for other stencil recommendations.
  - D. Contact the board fabrication site for recommended soldermask tolerances.

## IMPORTANT NOTICE

Texas Instruments Incorporated and its subsidiaries (TI) reserve the right to make corrections, modifications, enhancements, improvements, and other changes to its products and services at any time and to discontinue any product or service without notice. Customers should obtain the latest relevant information before placing orders and should verify that such information is current and complete. All products are sold subject to TI's terms and conditions of sale supplied at the time of order acknowledgment.

TI warrants performance of its hardware products to the specifications applicable at the time of sale in accordance with TI's standard warranty. Testing and other quality control techniques are used to the extent TI deems necessary to support this warranty. Except where mandated by government requirements, testing of all parameters of each product is not necessarily performed.

TI assumes no liability for applications assistance or customer product design. Customers are responsible for their products and applications using TI components. To minimize the risks associated with customer products and applications, customers should provide adequate design and operating safeguards.

TI does not warrant or represent that any license, either express or implied, is granted under any TI patent right, copyright, mask work right, or other TI intellectual property right relating to any combination, machine, or process in which TI products or services are used. Information published by TI regarding third-party products or services does not constitute a license from TI to use such products or services or a warranty or endorsement thereof. Use of such information may require a license from a third party under the patents or other intellectual property of the third party, or a license from TI under the patents or other intellectual property of TI.

Reproduction of TI information in TI data books or data sheets is permissible only if reproduction is without alteration and is accompanied by all associated warranties, conditions, limitations, and notices. Reproduction of this information with alteration is an unfair and deceptive business practice. TI is not responsible or liable for such altered documentation. Information of third parties may be subject to additional restrictions.

Resale of TI products or services with statements different from or beyond the parameters stated by TI for that product or service voids all express and any implied warranties for the associated TI product or service and is an unfair and deceptive business practice. TI is not responsible or liable for any such statements.

TI products are not authorized for use in safety-critical applications (such as life support) where a failure of the TI product would reasonably be expected to cause severe personal injury or death, unless officers of the parties have executed an agreement specifically governing such use. Buyers represent that they have all necessary expertise in the safety and regulatory ramifications of their applications, and acknowledge and agree that they are solely responsible for all legal, regulatory and safety-related requirements concerning their products and any use of TI products in such safety-critical applications, notwithstanding any applications-related information or support that may be provided by TI. Further, Buyers must fully indemnify TI and its representatives against any damages arising out of the use of TI products in such safety-critical applications.

TI products are neither designed nor intended for use in military/aerospace applications or environments unless the TI products are specifically designated by TI as military-grade or "enhanced plastic." Only products designated by TI as military-grade meet military specifications. Buyers acknowledge and agree that any such use of TI products which TI has not designated as military-grade is solely at the Buyer's risk, and that they are solely responsible for compliance with all legal and regulatory requirements in connection with such use.

TI products are neither designed nor intended for use in automotive applications or environments unless the specific TI products are designated by TI as compliant with ISO/TS 16949 requirements. Buyers acknowledge and agree that, if they use any non-designated products in automotive applications, TI will not be responsible for any failure to meet such requirements.

Following are URLs where you can obtain information on other Texas Instruments products and application solutions:

<b>Products</b>		<b>Applications</b>	
Amplifiers	<a href="http://amplifier.ti.com">amplifier.ti.com</a>	Audio	<a href="http://www.ti.com/audio">www.ti.com/audio</a>
Data Converters	<a href="http://dataconverter.ti.com">dataconverter.ti.com</a>	Automotive	<a href="http://www.ti.com/automotive">www.ti.com/automotive</a>
DLP® Products	<a href="http://www.dlp.com">www.dlp.com</a>	Communications and Telecom	<a href="http://www.ti.com/communications">www.ti.com/communications</a>
DSP	<a href="http://dsp.ti.com">dsp.ti.com</a>	Computers and Peripherals	<a href="http://www.ti.com/computers">www.ti.com/computers</a>
Clocks and Timers	<a href="http://www.ti.com/clocks">www.ti.com/clocks</a>	Consumer Electronics	<a href="http://www.ti.com/consumer-apps">www.ti.com/consumer-apps</a>
Interface	<a href="http://interface.ti.com">interface.ti.com</a>	Energy	<a href="http://www.ti.com/energy">www.ti.com/energy</a>
Logic	<a href="http://logic.ti.com">logic.ti.com</a>	Industrial	<a href="http://www.ti.com/industrial">www.ti.com/industrial</a>
Power Mgmt	<a href="http://power.ti.com">power.ti.com</a>	Medical	<a href="http://www.ti.com/medical">www.ti.com/medical</a>
Microcontrollers	<a href="http://microcontroller.ti.com">microcontroller.ti.com</a>	Security	<a href="http://www.ti.com/security">www.ti.com/security</a>
RFID	<a href="http://www.ti-rfid.com">www.ti-rfid.com</a>	Space, Avionics & Defense	<a href="http://www.ti.com/space-avionics-defense">www.ti.com/space-avionics-defense</a>
RF/IF and ZigBee® Solutions	<a href="http://www.ti.com/lprf">www.ti.com/lprf</a>	Video and Imaging	<a href="http://www.ti.com/video">www.ti.com/video</a>
		Wireless	<a href="http://www.ti.com/wireless-apps">www.ti.com/wireless-apps</a>

Mailing Address: Texas Instruments, Post Office Box 655303, Dallas, Texas 75265  
Copyright © 2010, Texas Instruments Incorporated