

THIS DRAWING IS UNPUBLISHED. RELEASED FOR PUBLICATION AUG 2006
 © COPYRIGHT BY TYCO ELECTRONICS CORPORATION. ALL RIGHTS RESERVED.

LOC	DIST	REVISIONS			
P	LTR	DESCRIPTION	DATE	DWN	APVD
DW	-	A3	REVISED (ECR-10-017194)	19AUG10	JL WK

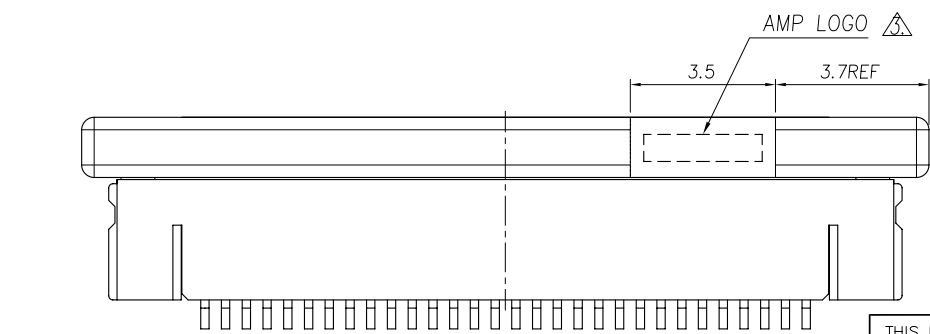
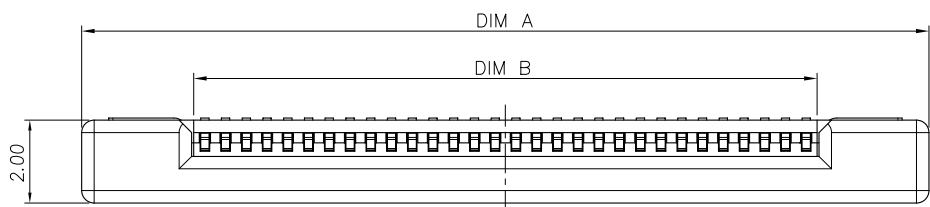
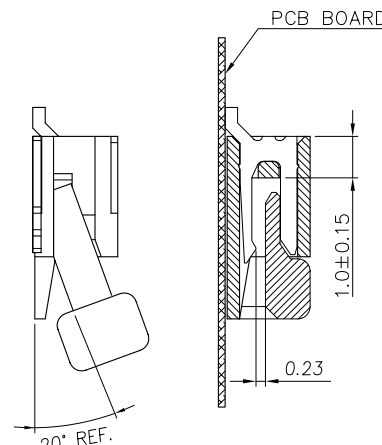
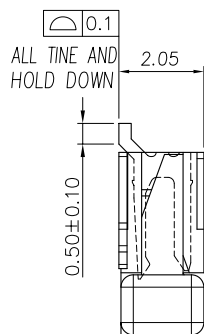
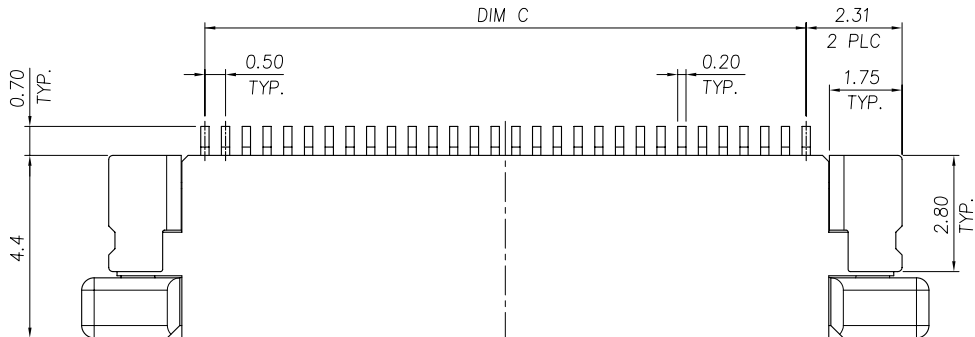

NOTE:
 1. MATERIAL:
 HOUSING: THERMOPLASTIC(LCP), UL 94V-0, COLOR: NATURE.
 ACTUATOR: THERMOPLASTIC, UL 94 V-0, COLOR: IVORY.
 HOLD DOWN: PHOSPHOR BRONZE.
 CONTACT: PHOSPHOR BRONZE.
 2. FINISH:
 CONTACT: GOLD FLASH OVER ALL, 50u" MIN. NICKEL UNDERPLATED ALL OVER.
 HOLD DOWN: 100u" MIN. BRIGHT TIN PLATING OVER, 50u" MIN. NICKEL UNDERPLATED ALL OVER.
 ⚠ WITHOUT AMP LOGO FOR 12 POSITION UNDER

24.50	25.60	30.43	50	5-1734592-0
24.00	25.10	29.93	49	4-1734592-9
23.50	24.60	29.43	48	4-1734592-8
23.00	24.10	28.93	47	4-1734592-7
22.50	23.60	28.43	46	4-1734592-6
22.00	23.10	27.93	45	4-1734592-5
21.50	22.60	27.43	44	4-1734592-4
21.00	22.10	26.93	43	4-1734592-3
20.50	21.60	26.43	42	4-1734592-2
20.00	21.10	25.93	41	4-1734592-1
19.50	20.60	25.43	40	4-1734592-0
19.00	20.10	24.93	39	3-1734592-9
18.50	19.60	24.43	38	3-1734592-8
18.00	19.10	23.93	37	3-1734592-7
17.50	18.60	23.43	36	3-1734592-6
17.00	18.10	22.93	35	3-1734592-5
16.50	17.60	22.43	34	3-1734592-4
16.00	17.10	21.93	33	3-1734592-3
15.50	16.60	21.43	32	3-1734592-2
15.00	16.10	20.93	31	3-1734592-1
14.50	15.60	20.43	30	3-1734592-0
14.00	15.10	19.93	29	2-1734592-9
13.50	14.60	19.43	28	2-1734592-8
13.00	14.10	18.93	27	2-1734592-7
12.50	13.60	18.43	26	2-1734592-6
12.00	13.10	17.93	25	2-1734592-5
11.50	12.60	17.43	24	2-1734592-4
11.00	12.10	16.93	23	2-1734592-3
10.50	11.60	16.43	22	2-1734592-2
10.00	11.10	15.93	21	2-1734592-1
9.50	10.60	15.43	20	2-1734592-0
9.00	10.10	14.93	19	1-1734592-9
8.50	9.60	14.43	18	1-1734592-8
8.00	9.10	13.93	17	1-1734592-7
7.50	8.60	13.43	16	1-1734592-6
7.00	8.10	12.93	15	1-1734592-5
6.50	7.60	12.43	14	1-1734592-4
6.00	7.10	11.93	13	1-1734592-3
5.50	6.60	11.43	12	1-1734592-2
5.00	6.10	10.93	11	1-1734592-1
4.50	5.60	10.43	10	1-1734592-0
4.00	5.10	9.93	09	0-1734592-9
3.50	4.60	9.43	08	0-1734592-8
3.00	4.10	8.93	07	0-1734592-7
2.50	3.60	8.43	06	0-1734592-6
2.00	3.10	7.93	05	0-1734592-5
C	B	A	POS.	PART NUMBER
DIMENSIONS				

25-05516
nLIGHT Part #

THIS DRAWING IS A CONTROLLED DOCUMENT.

DIMENSIONS: MM	TOLERANCES UNLESS OTHERWISE SPECIFIED: 0 PLC ± 0.1 1 PLC ± 0.1 2 PLC ± 0.1 3 PLC ± 0.1 4 PLC ± 0.1 ANGLES ± 1°	DWN J. LAI 15APR2009 CHK S. CHIEN 15APR2009 APVD W. KODAMA 15APR2009	Tyco Electronics Corporation Taipei, Taiwan	
MATERIAL SEE NOTE	FINISH SEE NOTE	PRODUCT SPEC 108-57523 QUALIFICATION TEST REPORT 501-57598 WEIGHT - GRAMS	NAME FPC CONNECTOR, 0.5mm PITCH, BOTTOM CONTACT, SMT TYPE. SIZE CAGE CODE DRAWING NO RESTRICTED TO A3 00779 C=1734592 -	
CUSTOMER DRAWING		SCALE -	SHEET 1 of 3	REV A3

4

3

2

1

THIS DRAWING IS UNPUBLISHED.

RELEASED FOR PUBLICATION

AUG 2006

© COPYRIGHT BY TYCO ELECTRONICS CORPORATION.

ALL RIGHTS RESERVED.

LOC DW

DIST

REVISIONS

P	LTR	DESCRIPTION	DATE	DWN	APVD
		SEE SHEET 1.			

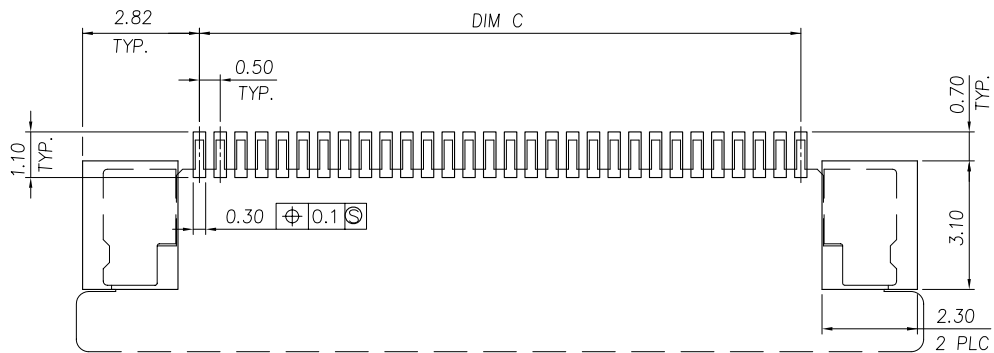

RECOMMENDED PCB DIMENSIONS DIAGRAM
TOLERANCE ± 0.05

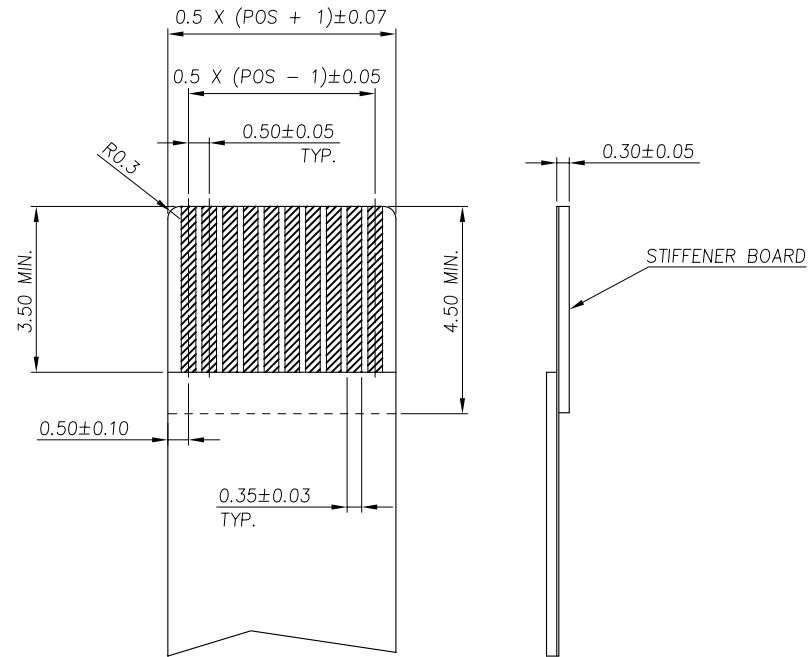

RECOMMENDED FPC DIMENSIONS DIAGRAM
TOLERANCE ± 0.05

THIS DRAWING IS A CONTROLLED DOCUMENT.		DWN	Tyco Electronics Corporation Taipei, Taiwan	
DIMENSIONS: MM		CHK	NAME	
TOLERANCES UNLESS OTHERWISE SPECIFIED:		APVD	FPC CONNECTOR, 0.5mm PITCH, BOTTOM CONTACT, SMT TYPE.	
0 PLC ± -		PRODUCT SPEC	SIZE	CAGE CODE
1 PLC ± -		APPLICATION SPEC	A3	00779
2 PLC ± -		WEIGHT	C=	1734592
3 PLC ± -		CUSTOMER DRAWING	SCALE	SHEET
4 PLC ± -				2 of 3
ANGLES ± -				REV A3

THIS DRAWING IS UNPUBLISHED. RELEASED FOR PUBLICATION AUG 2006
 © COPYRIGHT BY TYCO ELECTRONICS CORPORATION. ALL RIGHTS RESERVED.

LOC	DIST	REVISIONS			
P	LTR	DESCRIPTION	DATE	DWN	APVD
		SEE SHEET 1.			

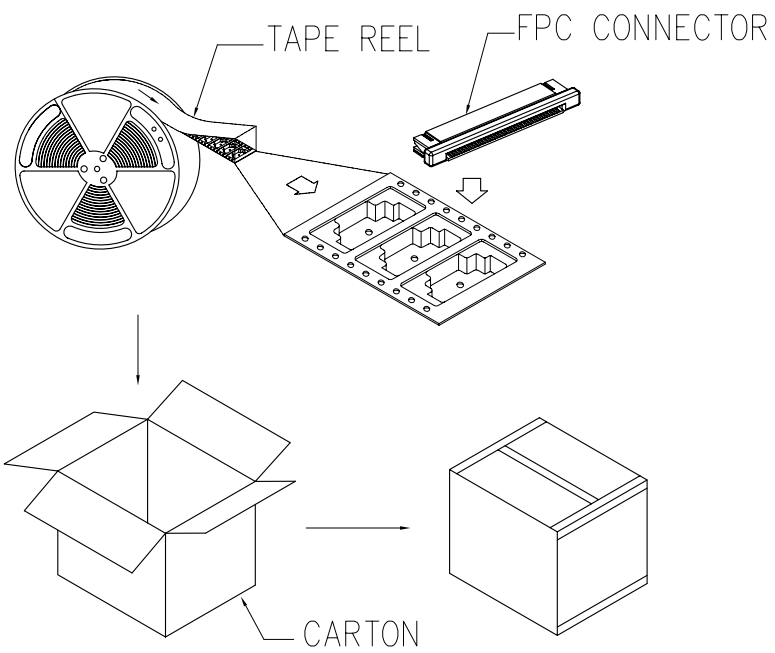
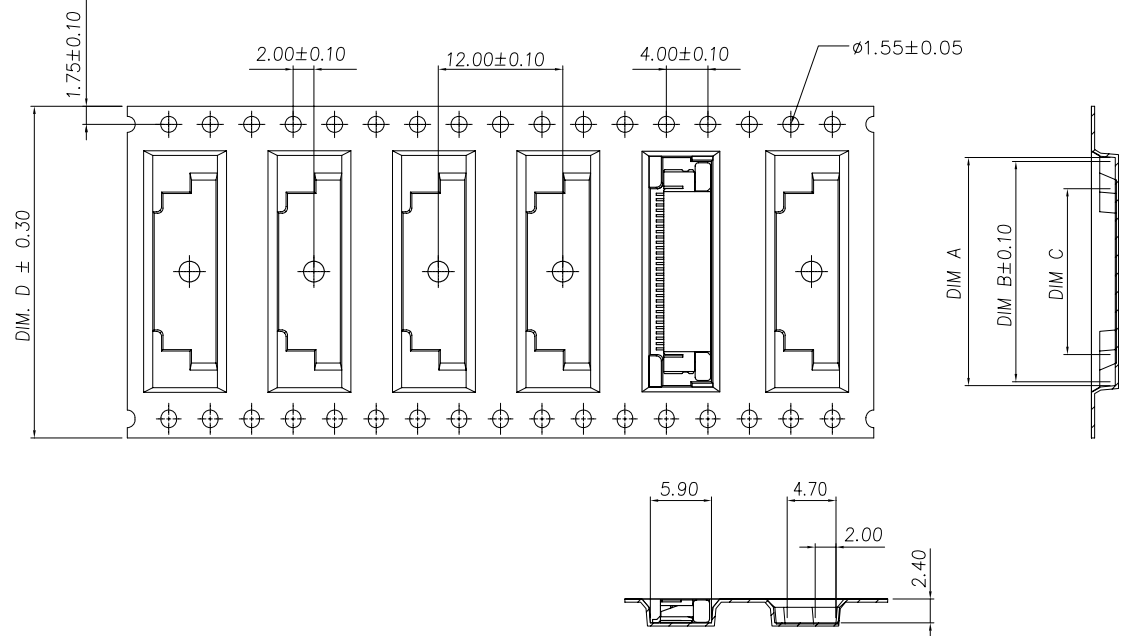

NOTE :
 1. TAPE REEL:
 DIAMETER: 13", THICKNESS : 0.35±0.05mm.
 2. CARTON:
 SIZE: 350mm(L)X 350mm(W)X 340mm(H).

DIMENSIONS	D	C	B	A	POS.
12000	44.00	25.50	30.75	31.50	50
	44.00	25.00	30.25	31.00	49
	44.00	24.50	29.75	30.50	48
	44.00	24.00	29.25	30.00	47
	44.00	23.50	28.75	29.50	46
	44.00	23.00	28.25	29.00	45
	44.00	22.50	27.75	28.50	44
	44.00	22.00	27.25	28.00	43
	44.00	21.50	26.75	27.50	42
	44.00	21.00	26.25	27.00	41
	44.00	20.50	25.75	26.50	40
	44.00	20.00	25.25	26.00	39
16000	44.00	19.50	24.75	25.50	38
	44.00	19.00	24.25	25.00	37
	44.00	18.50	23.75	24.50	36
	44.00	18.00	23.25	24.00	35
	44.00	17.50	22.75	23.50	34
	44.00	17.00	22.25	23.00	33
	44.00	16.50	21.75	22.50	32
	32.00	16.00	21.25	22.00	31
	32.00	15.50	20.75	21.50	30
	32.00	15.00	20.25	21.00	29
	32.00	14.50	19.75	20.50	28
	32.00	14.00	19.25	20.00	27
20000	32.00	13.50	18.75	19.50	26
	32.00	13.00	18.25	19.00	25
	32.00	12.50	17.75	18.50	24
	32.00	12.00	17.25	18.00	23
	32.00	11.50	16.75	17.50	22
	24.00	11.00	16.25	17.00	21
	24.00	10.50	15.75	16.50	20
	24.00	10.00	15.25	16.00	19
	24.00	9.50	14.75	15.50	18
	24.00	9.00	14.25	15.00	17
	24.00	8.50	13.75	14.50	16
	24.00	8.00	13.25	14.00	15
24000	24.00	7.50	12.75	13.50	14
	24.00	7.00	12.25	13.00	13
	24.00	6.50	11.75	12.50	12
	24.00	6.00	11.25	12.00	11
	24.00	5.50	10.75	11.50	10
	24.00	5.00	10.25	11.00	09
	24.00	4.50	9.75	10.50	08
	24.00	4.00	9.25	10.00	07
	24.00	3.50	8.75	9.50	06
	16.00	3.00	8.25	9.00	05

THIS DRAWING IS A CONTROLLED DOCUMENT.

DIMENSIONS: MM	TOLERANCES UNLESS OTHERWISE SPECIFIED: 0 PLC ± - 1 PLC ± - 2 PLC ± - 3 PLC ± - 4 PLC ± - ANGLES ± -	DWN	Tyco Electronics Corporation Taipei, Taiwan
	MATERIAL	CHK	
	FINISH	APVD	
		PRODUCT SPEC	
		APPLICATION SPEC	NAME
		WEIGHT	FPC CONNECTOR, 0.5mm PITCH, BOTTOM CONTACT, SMT TYPE.
		CUSTOMER DRAWING	SIZE CAGE CODE DRAWING NO RESTRICTED TO
			A3 00779 C=1734592
		SCALE SHEET	3 of 3 REV A3

**FPC Connector, 0.5mm Pitch, Connector SMT
Type**

1. SCOPE

1.1. CONTENTS

This specification covers the performance, tests and quality requirements for the FPC Connector, 0.5mm Pitch Connector SMT Type.

1.2. QUALIFICATION

When tests are performed on the subject product line, the procedures specified in TE 109 series specifications shall be used. All inspections shall be performed using the applicable inspection plan and product drawing.

2. APPLICABLE DOCUMENT

The following TE documents form a part of this specification to the extent specified herein. Unless otherwise specified, the latest edition of the document applies. In the event of conflict between the requirements of this specification and the product drawing, the product drawing shall take precedence. In the event of conflict between the requirements of this specification and the referenced documents, this specification shall take precedence.

2.1. TE SPECIFICATIONS

- A. 109-1 : General Requirements for the Test Specification
- B. 109-197 : TE Specification vs EIA and IEC Test Methods
- C. 501-57598 : Test Report

3. REQUIREMENTS

3.1. DESIGN AND CONSTRUCTION

Product shall be of the design, construction and physical dimensions specified on the applicable product drawing.

3.2. MATERIALS

- A. Housing : Thermoplastic, UL94V-0
- B. Actuator : Thermoplastic, UL94 V-0
- C. Contact : Copper Alloy, Tin Plating or Gold Plating over Nickel under-plating.
- D. Hold Down : Copper Alloy, Tin Plating over Nickel under-plating.

3.3. RATINGS

- A. Voltage: 250 VAC
- B. Current: 0.5 A Max
- C. Temperature: - 40 °C to 125 °C

DR	DATE	APVD	DATE
Scott Chien	13-MAY-2010	William Kodama	13-MAY-2010

3.4. PERFORMANCE REQUIREMENT AND TEST DESCRIPTION

The product shall be designed to meet the electrical, mechanical and environmental performance requirements specified in Figure 1. All tests shall be performed at ambient environmental conditions per AMP Specification 109-1 TEST REQUIREMENTS AND PROCEDURES SUMMARY.

3.5. TEST REQUIREMENTS AND PROCEDURES SUMMARY

Test Item		Requirement	Procedure
1	Examination of Product	Meets requirements of product drawing. No physical damage.	Visual inspection. No physical damage
ELECTRICAL REQUIREMENT			
2	Contact Resistance	35mΩ . Max.	Subject mated contacts assembled in housing to 20 mV DC Max open circuit at 100mA MIL-STD-1344A Method 3002.1
3	Insulation Resistance	100M Ohm Min.(Initial) 50M Ohm Min. (Final)	Impressed voltage 500VDC. The insulation resistance shall be measured between 10 adjacent 10 opposing contacts per FPC connector. MIL-STD-202F, Method 302
4	Dielectric Withstanding Resistance	No creeping discharge or flashover shall occur. Current leakage:0.5mA MAX	250VAC for 1minute Test between adjacent circuits of unmated connector. MIL-STD-202F Method 301
MECHANICAL REQUIREMENT			
Test Item		Requirement	Procedure
5	Durability	See Note	Operation Speed: 25.4mm/minute Durability Cycles:15 Cycles
6	Vibration	No electrical discontinuity greater than 1microsecond shall occur. See Note.	(1)Test duration:3 hours along Each of 3 mutually perpendicular Plans(9hours totally) (2)Test board thickness:1.6±0.02mm MIL-STD-1344A,Method 2005
7	Physical Shock	During and after each shock, the contacts shall be no discontinuity greater then 1 microsecond.	(1)Number of drops:3 drops in each of 3 mutually perpendicular planes (2)Test board thickness:1.6±0.02mm MIL-STD-202F,Method 213.
8	Contact Retention Force	250 gf min.	The test shall be performed 10PCS of each different row of contacts the crosshead speed should be less than 20mm per minute.
9	Solder ability	Wet solder coverage:95% Min.	Solder Temp.:235±5°C Duration: 5±0.5sec. MIL-STD-202F,Method 208D.

Figure 1 (cont)

MECHANICAL REQUIREMENT		
Test Item	Requirement	Procedure
10	Humidity	See Note
10	Humidity	(a)test condition:B (b)relative humidity:90±5% (c)temperature:40±3℃ (d)test duration:96 hours Within one hour after exposure MIL-STD-202F,Method 103B.
11	Salt Spray	No detrimental corrosion allowed in contact area and base metal exposed.
11	Salt Spray	Subject mated connectors to 35±2℃ and 5±1% salt(NaCl) for 48hrs. After test, rinse the sample with water and recondition the room temperature for 48hrs. MIL-STD-202F,Method 101D.1. condition B.
12	Thermal Shock	See Note
12	Thermal Shock	(a)temperature range: -55±5℃ to +85±5℃ (b)time at each temperature: 30minutes (c)transfer time:5 minutes max. (d)number of cycles:5 cycles EIA-364-32C.
13	Temperature Life	See Note
13	Temperature Life	(a)test temperature:125±2℃ (b)test duration:96 hours EIA-364-17B
14	Resistance to Reflow Soldering Heat	No physical damage shall occur. (Lead-Free)
14	Resistance to Reflow Soldering Heat	Pre-soak condition, 85℃/85% RH for 168 hours. Pre Heat : 150~180℃, 90±30sec. Heat : 230℃ Min., 30±10sec. Peak Temp. : 260+0/-5℃, 20~40sec. Duration : 3 cycles TE spec. 109-201, Condition B

Figure 1 (End)

NOTE : Shall meet visual requirements, show no physical damage, and meet requirement of additional tests as specified in the test sequence in Figures 2

3.6. PRODUCT QUALIFICATION AND REQUALIFICATION TEST

Test or Examination	Test Group								
	A	B	C	D	E	F	G	H	I
	Test Sequence (a)								
Examination of Product	1,9	1,9	1,9	1,7	1,3	1,6	1,3	1,3	1,5
Contact Resistance	2,6	2,6	2,6	2,6		2,5			2,4
Insulation Resistance	3,7	3,7	3,7	3,5					
Dielectric Withstanding Resistance	4,8	4,8	4,8	4					
Durability									
Vibration						3			
Physical Shock						4			
Contact Retention Force					2				
Solder ability							2		
Humidity	5								
Salt Spray		5							
Thermal Shock								2	
Temperature Life			5						
Resistance To Reflow Soldering Heat									3

Figure 2

NOTE : (a) Numbers indicate sequence in which tests are performed.

(b) Discontinuities shall not take place in this test group, during tests.