

25-05442

QSI LASER DIODE SPECIFICATIONS FOR APPROVAL

Customer :

Model : QL90F7S-A/B/C

Signature of Approval

Approved by _____

Checked by _____

Issued by _____

Approval by Customer



QSI Co., Ltd.

315-9, Cheonheung-ri, Sungger-eup,
Cheonan-city, Chungnam, Korea 330-836

WWW.QSILaser.com

QL90F7S-A/B/C

InGaAs Laser Diode

Quantum Semiconductor International Co., Ltd.

Jun.2004. Ver. 0

◆ OVERVIEW

QL90F7S-A/B/C is a MOCVD grown 905nm band *InGaAs* laser diode with quantum well structure. It's an attractive light source, with a typical light output power of 10mW for Laser, industrial optical module and sensor application

◆ APPLICATION

- Sensor

◆ FEATURES

- Visible Light Output : $\lambda_p = 905 \text{ nm}$
- Optical Power Output : 10mW CW
- Package Type : TO-18 (5.6mm ϕ)
- Built-in Photo Diode for Monitoring Laser Diode

◆ ELECTRICAL CONNECTION

Bottom View

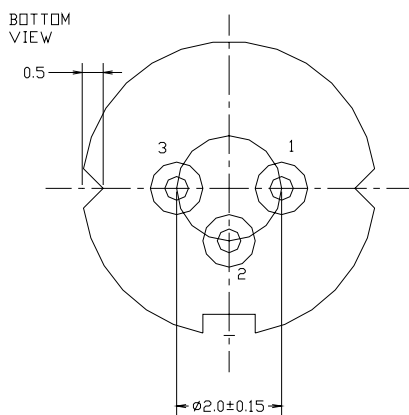

Pin Configuration

A	LD cathode, PD anode (Fig. 1)
B	LD , PD anode (Fig. 2)
C	LD anode, PD cathode (Fig. 3)

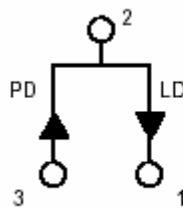

Fig. 1

QL90F7SA

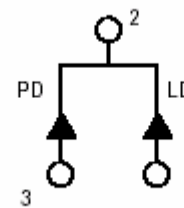

Fig. 2

QL90F7SB

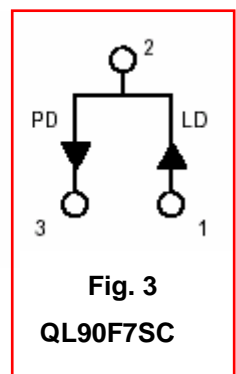

Fig. 3

QL90F7SC

◆ ABSOLUTE MAXIMUM RATING at Tc=25°C

Items	Symbols	Values	Unit
Optical Output Power	P	12	mW
Laser Diode Reverse Voltage	V	2	V
Photo Diode Reverse Voltage	V	30	V
Operating Temperature	Topr	-10 ~ +70	°C
Storage Temperature	Tstg	-40 ~ +85	°C

◆ ELECTRICAL and OPTICAL CHARACTERISTICS at Tc=25°C

Items	Symbols	Min.	Typ.	Max.	Unit	Condition
Optical Output Power	Po	-	10	-	mW	-
Threshold Current	Ith	-	12	25	mA	-
Operating Current	Iop	-	35	60	mA	Po=10mW
Operating Voltage	Vop	1.5	1.8	2.3	V	Po=10mW
Slope Efficiency	SE	0.3	0.5	0.7	mW/mA	
Lasing Wavelength	λ_p	885	905	915	nm	Po=10mW
Beam Divergence	$\theta_{ }$	7	10	15	deg	Po=10mW
	θ_{\perp}	28	35	38	deg	Po=10mW
Beam Angle	$\Delta\theta_{ }$	-	-	±2.5	deg	Po=10mW
	$\Delta\theta_{\perp}$	-	-	±3.0	deg	Po=10mW
Monitor Current	Im	0.1	0.4	0.6	mA	Po=10mW
Optical Distance	$\Delta X, \Delta Y, \Delta Z$	-	-	60	μm	Po=10mW

NOTICE : QL90F7S-A/B/C to be operated on APC

The above product specifications are subject to change without notice.



◆ PACKAGE DIMENSION

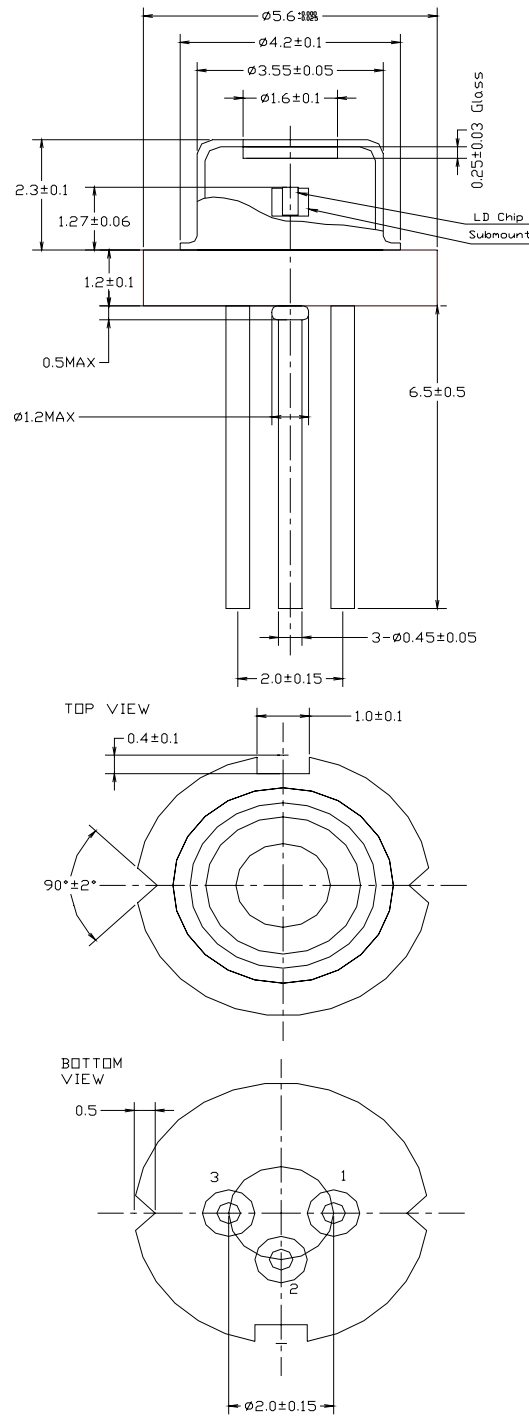

◆PACKING

