

LOC		DIST		REVISIONS			
CM	00	P	LTR	DESCRIPTION	DATE	DMN	APVD
		W		REVISED PER 063B-0167-04	14JUN04	KW	DB
		W1		REVISED PER ECO-10-000443	15JAN10	KK	HMR

25-05407

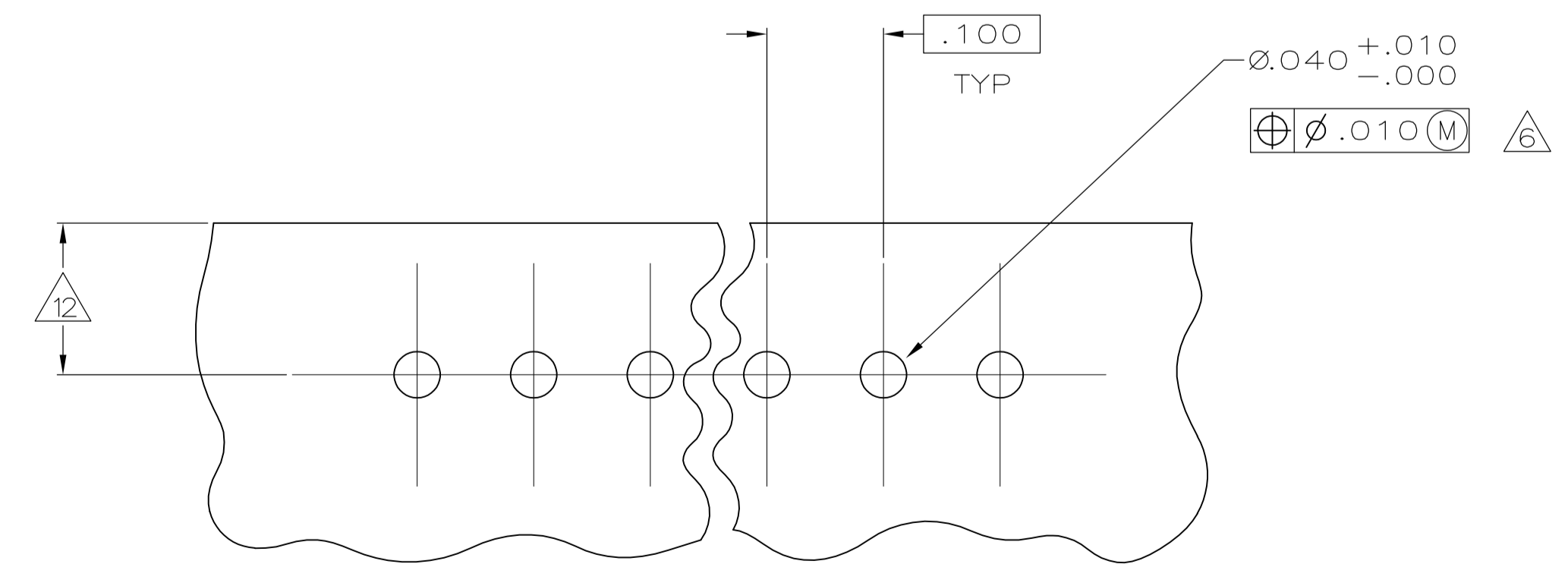
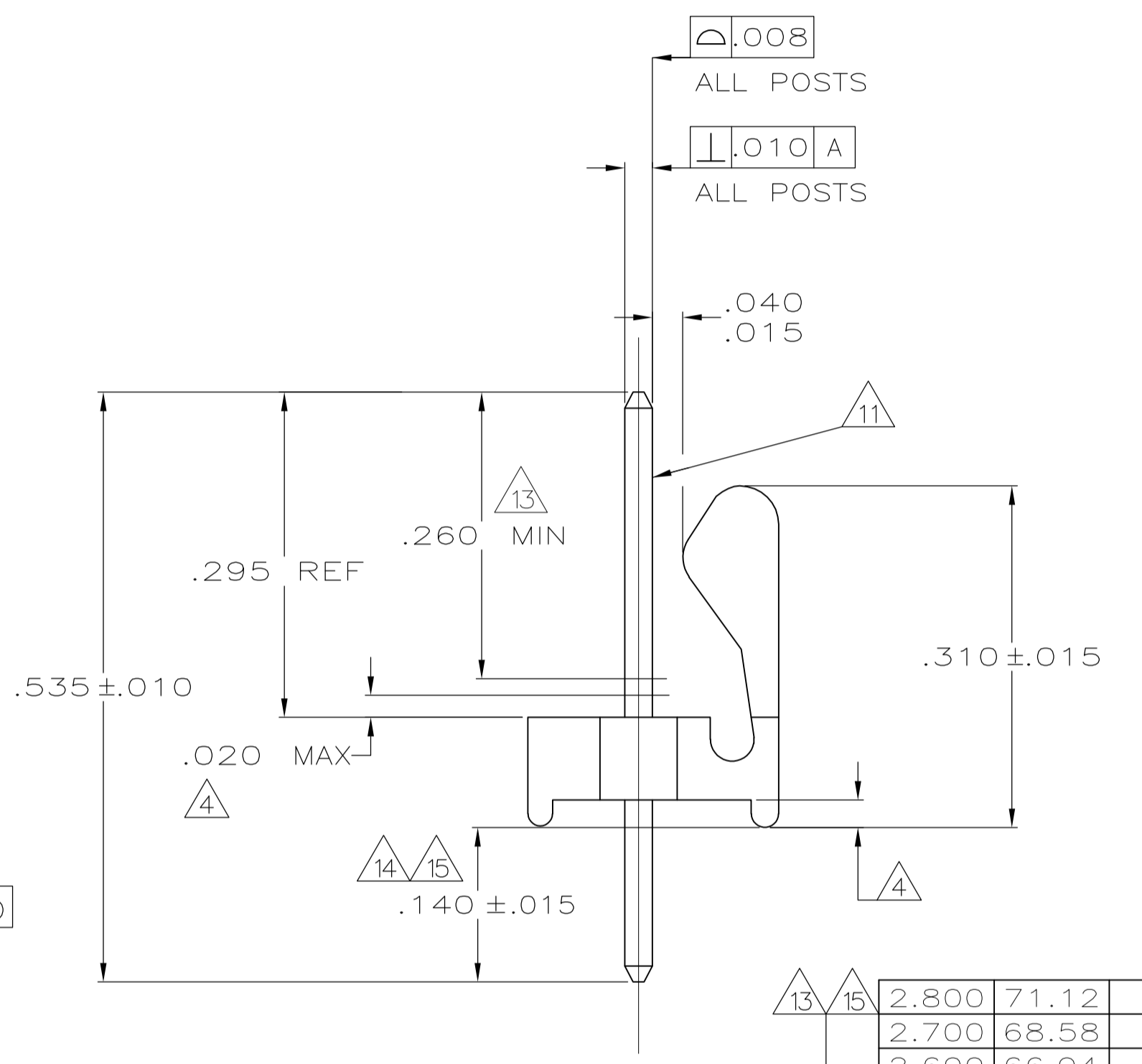
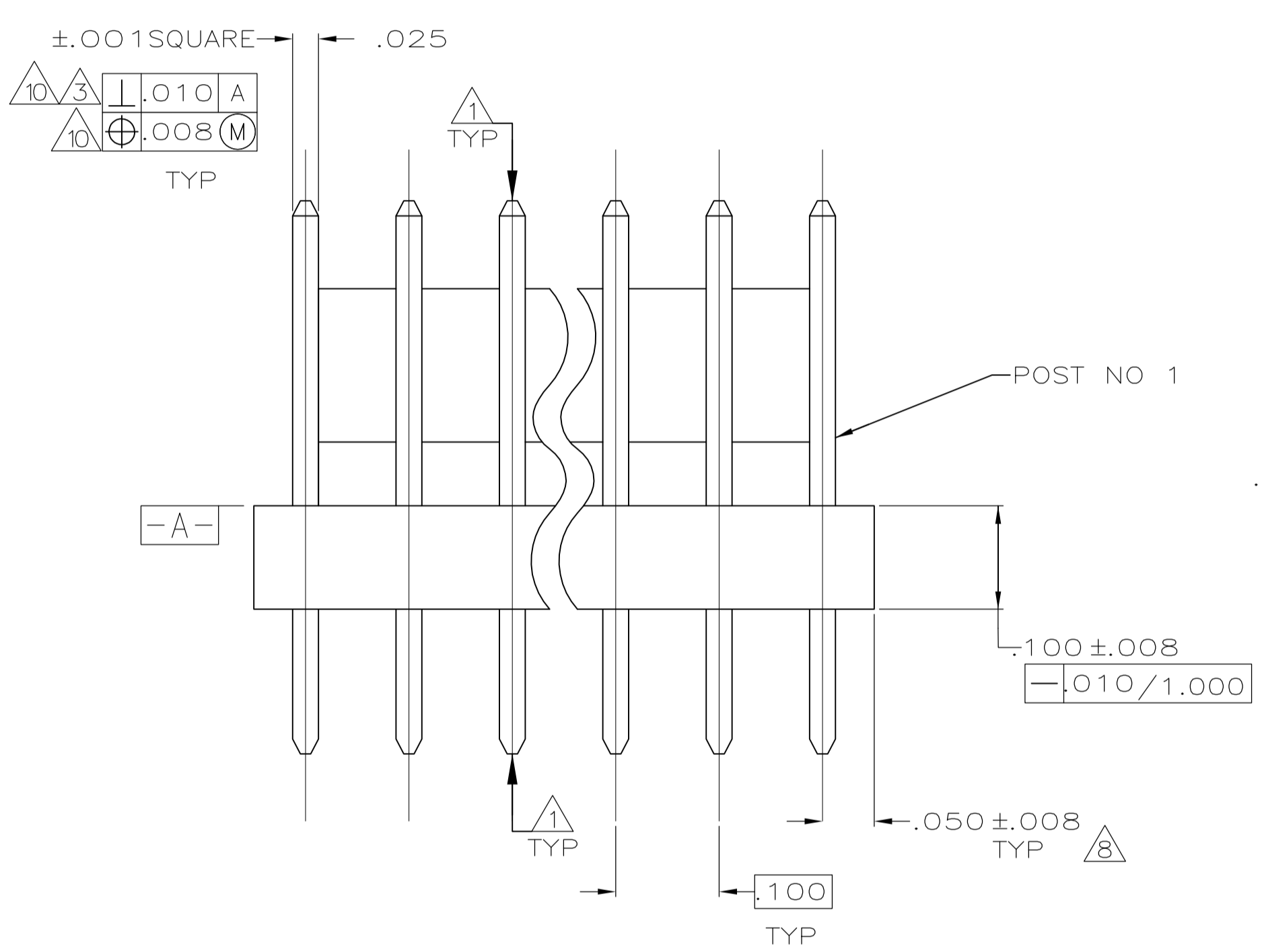
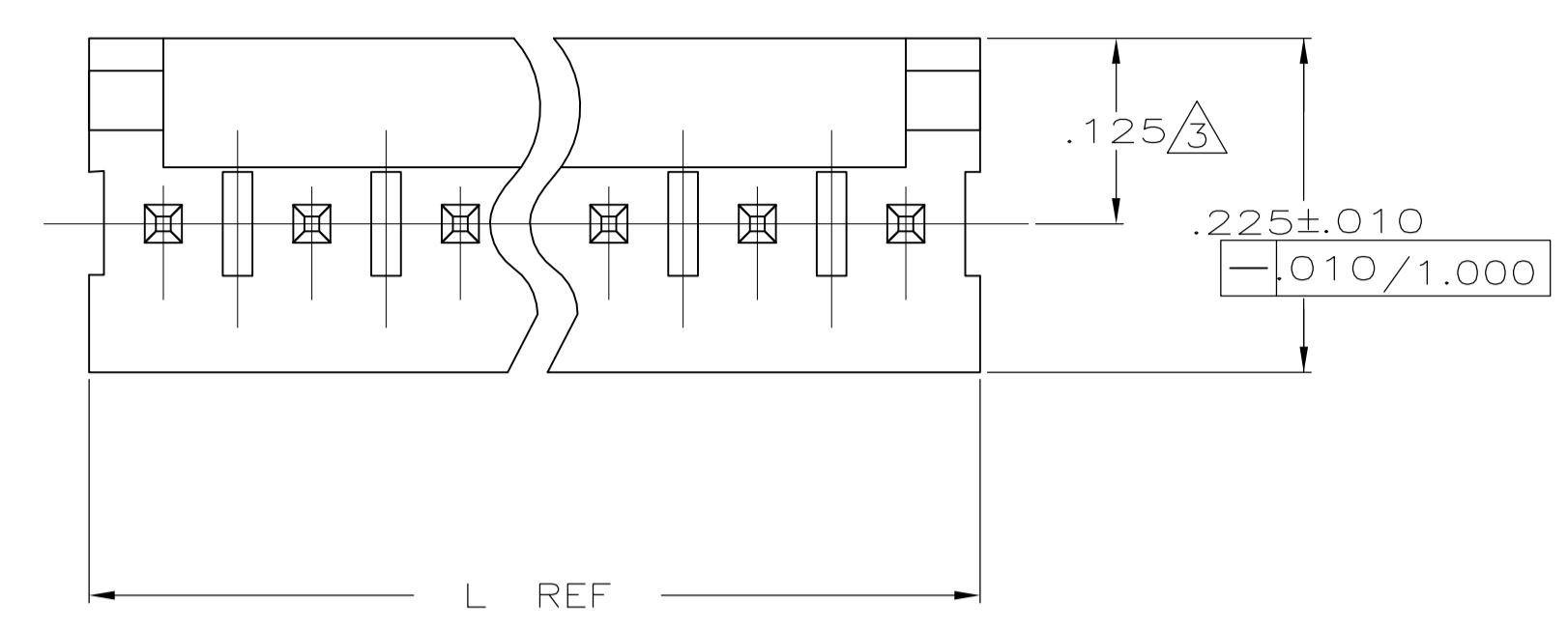

IN	MM	IN	MM
.040	1.02		
.035	0.89		
.032	0.81		
.025	0.64	1.000	25.40
.020	0.51	.535	13.59
.015	0.38	.310	7.87
.010	0.25	.295	7.49
.008	0.20	.260	6.60
.005	0.13	.225	5.72
.001	0.03	.140	3.56
.000350	0.00889	.130	3.30
.000150	0.00381	.125	3.18
.000050	0.00127	.100	2.54
.000030	0.00076	.063	1.60
.000	0.00	.050	1.27

CONVERSION TABLE

RECOMMENDED MOUNTING HOLE PATTERN FOR .063 THICK P.C. BOARD

IN	MM	NO OF POSITIONS	PART NUMBER
2.800	71.12	28	5-641215-8
2.700	68.58	27	5-641215-7
2.600	66.04	26	5-641215-6
2.500	63.50	25	5-641215-5
2.400	60.96	24	5-641215-4
2.300	58.42	23	5-641215-3
2.200	55.88	22	5-641215-2
2.100	53.34	21	5-641215-1
2.000	50.80	20	5-641215-0
1.900	48.26	19	4-641215-9
1.800	45.72	18	4-641215-8
1.700	43.18	17	4-641215-7
1.600	40.64	16	4-641215-6
1.500	38.10	15	4-641215-5
1.400	35.56	14	4-641215-4
1.300	33.02	13	4-641215-3
1.200	30.48	12	4-641215-2
1.100	27.94	11	4-641215-1
1.000	25.40	10	4-641215-0
.900	22.86	9	3-641215-9
.800	20.32	8	3-641215-8
.700	17.78	7	3-641215-7
.600	15.24	6	3-641215-6
.500	12.70	5	3-641215-5
.400	10.16	4	3-641215-4
.300	7.62	3	3-641215-3
.200	5.08	2	3-641215-2

IN	MM	NO OF POSITIONS	PART NUMBER
2.800	71.12	28	2-641215-8
2.700	68.58	27	2-641215-7
2.600	66.04	26	2-641215-6
2.500	63.50	25	2-641215-5
2.400	60.96	24	2-641215-4
2.300	58.42	23	2-641215-3
2.200	55.88	22	2-641215-2
2.100	53.34	21	2-641215-1
2.000	50.80	20	2-641215-0
1.900	48.26	19	1-641215-9
1.800	45.72	18	1-641215-8
1.700	43.18	17	1-641215-7
1.600	40.64	16	1-641215-6
1.500	38.10	15	1-641215-5
1.400	35.56	14	1-641215-4
1.300	33.02	13	1-641215-3
1.200	30.48	12	1-641215-2
1.100	27.94	11	1-641215-1
1.000	25.40	10	1-641215-0
.900	22.86	9	641215-9
.800	20.32	8	641215-8
.700	17.78	7	641215-7
.600	15.24	6	641215-6
.500	12.70	5	641215-5
.400	10.16	4	641215-4
.300	7.62	3	641215-3
.200	5.08	2	641215-2

- 1. POST TO WITHSTAND 13 NEWTONS (3 LBS) MIN. AXIAL FORCE IN BOTH DIRECTIONS SHOWN WITHOUT DISLODGING.
- 2. TOLERANCES APPLY TO SOLDER SIDE OF BOARD.
- 3. MEASURED AT SURFACE -A-
- 4. PLASTIC FLASH PERMITTED IN THIS AREA.
- 5. PARTS COMPLY WITH AMP SOLDERABILITY SPEC. NO. 109-11-2.
- 6. ONE HOLE MAY BE UNDERSIZED (.032-.035 DIA) FOR ASSEMBLY RETENTION DURING WAVE SOLDERING.
- 7. MATERIAL: HEADER-THERMOPLASTIC POLYESTER
UL94V-0(NATURAL)
POST-COPPER ALLOY (SEE NOTES 13 & 14 FOR PLATING)
- 8. COORDINATE DIMENSION APPLIES FROM CENTER OF ACTUAL FEATURE.
- 9. PLASTIC BURRS CAUSED BY CUT-OFF TOOLING ARE PERMITTED WITHIN THE MAXIMUM TOLERANCE ENVELOPE.
- 10. POSTS TO BE MEASURED WHEN STRIP IS HELD FLAT.
- 11. POSTS MUSTS WITHSTAND TWO 90° BENDS AGAINST EXTRUSION WITHOUT BREAKING.
- 12. DIMENSION SHOULD BE .130 MIN WHEN MATING WITH A MTA 100 CONNECTOR ASSEMBLY OR A CST 100 CONNECTOR.
- 13. GOLD PLATE AREA,.000030 MIN.,ALL SIDES,OVER NICKEL UNDERPLATE,.000050 MIN.,ALL SIDES AND ENTIRE LENGTH OF POST.
- 14. BRIGHT TIN/LEAD (93/7) PLATE AREA,.000150-.000350 THICK,ALL FOUR SIDES,.140 MIN.
- 15. TIN PLATE AREA,.000150-.000350 THICK,ALL FOUR SIDES,.140 MIN.
- 16. OBSOLETE PARTS: OBSOLETE CIS STREAMLINING PER D.RENAUD/D.SINISI

METRIC

THIS DRAWING IS A CONTROLLED DOCUMENT.

DIMENSIONS: INCHES	TOLERANCES UNLESS OTHERWISE SPECIFIED:	0. PLC ± -	1. PLC ± -	2. PLC ± -	3. PLC ± .005	4. PLC ± -	ANGLES ± 0°30'
MATERIAL	FINISH	WEIGHT	SIZE	SCALE	CAGE CODE	DRAWING NO	RESTRICTED TO
			A1	8:1	00779	641215	REV W1

APPROVED: D. ROSSI
 NAME: D. ROSSI
 DATE: 11JUN04
 Tyco Electronics Corporation
 Greensboro, NC 27409
 MTA-100 HEADER ASSEMBLY, FRICTION LOCK, NOTCHED, .025 SQUARE STRAIGHT POST, .000030 GOLD PLATED
 CUSTOMER DRAWING