

25-05279

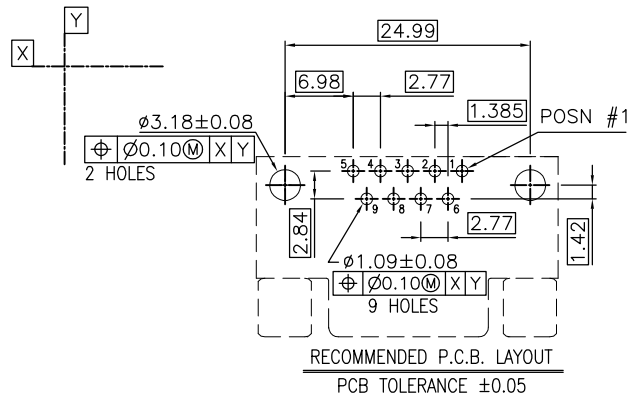

- NOTES:
- MATERIAL:
 - HOUSING: NY9T WITH 30% G.F. UL 94V-0, COLOR: BLACK
 - CONTACTS: PHOSPHOR BRONZE
 - SHELL: SPCC
 - BOARDLOCKS: BRASS
 - RIVET: BRASS
 - SCREWLOCKS: BRASS, THREAD LENGTH OF SCREW: 6.0 MIN.
 - FINISH:
 - CONTACT: GOLD PLATING ON CONTACT AREA. (SEE TABLE)
 2.54µm[100µ"] MIN. MATTE-TIN PLATING ON SOLDER TAIL,
 1.27µm[50µ"] MIN. NICKEL UNDERPLATED ON ENTIRE CONTACT.
 - BOARDLOCK: 2.54µm[100µ"] MIN. MATTE-TIN PLATING OVER
 1.27µm[50µ"] MIN. NICKEL UNDERPLATED ON ENTIRE CONTACT.
 - SHELL: NICKEL PLATED
 - RIVET: NICKEL PLATED
 - SCREWLOCKS: NICKEL PLATED
 - NET WEIGHT: 8.9 gram/PC.
 - THREADED INSERTS AND SCREWLOCKS MUST WITHSTAND 6 IN-LBS TORQUE.
 - DAET CODE: YYWW
 - REFLOW SOLDER CAPABLE TO 260°C PER TE CONNECTIVITY SPEC. 109-201, CONDITION B.

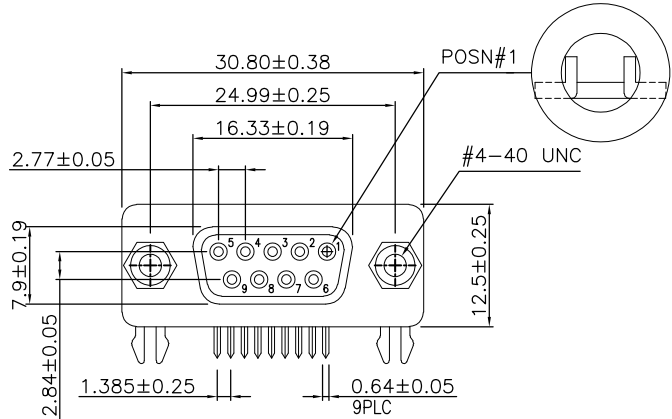
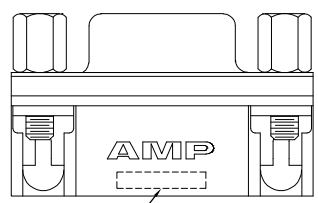
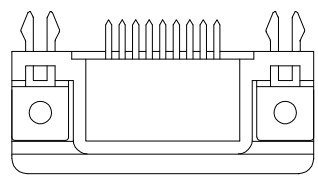
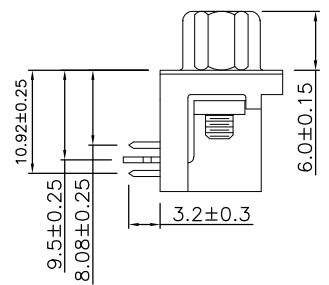
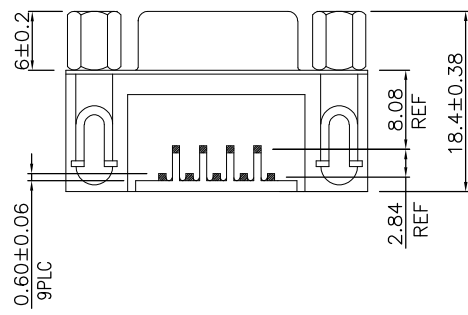

0.38µm[15u"]	1734354-2
GOLD-FLASH	1734354-1
CONTACT FINISH MIN.	PART NO.

DATE CODE

THIS DRAWING IS A CONTROLLED DOCUMENT.

DWN J. LEE 17NOV2006	NAME TE TE Connectivity						
CHK S. HOU 17NOV2006							
APVD W.J. KE 17NOV2006							
DIMENSIONS: MM	TOLERANCES UNLESS OTHERWISE SPECIFIED:	PRODUCT SPEC 108-57541	QUALIFICATION TEST REPORT 501-57623	SIZE A3	CAGE CODE 00779	DRAWING NO C-1734354	RESTRICTED TO -
MATERIAL SEE NOTE	FINISH SEE NOTE	WEIGHT SEE NOTE	CUSTOMER DRAWING	SCALE -	SHEET 1 OF 2	REV A1	

THIS DRAWING IS UNPUBLISHED. RELEASED FOR PUBLICATION
 © COPYRIGHT - BY - ALL RIGHTS RESERVED.

LOC		DIST		REVISIONS					
DW		-		P	LTR	DESCRIPTION	DATE	DWN	APVD
				-		SEE SHEET 1.	-	-	-

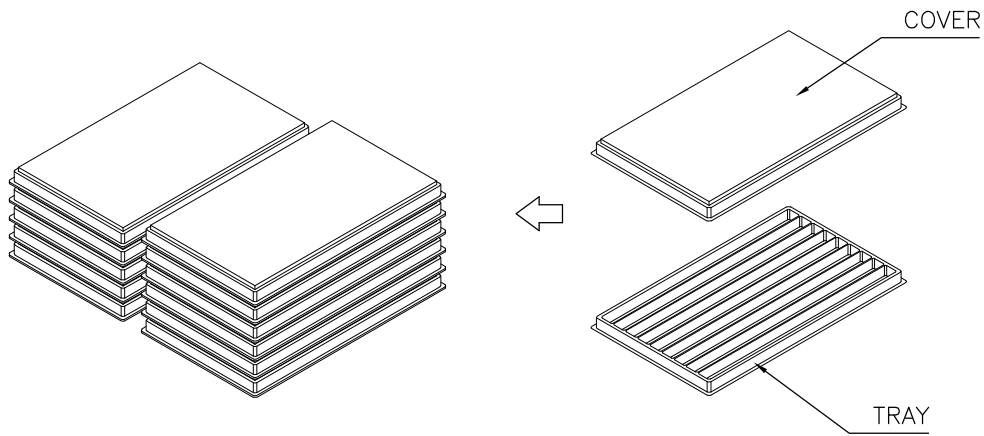

- NOTES:
- MATERIAL:
 - 1.1 TRAY: PVC
 - 1.2 SHIPPING CARTON: CORRUGATED FIBERBOARD
 - DIMENSION:
 - 2.1 TRAY: L=306, W=217, H=15.8
 - 2.2 SHIPPING CARTON: L=440, W=321, H=153
 - QUANTITY:
 - 3.1 PRIMARY PACKING: 90 PCS/TRAY
 - 3.2 SECONDARY PACKING: 11 TRAY/CARTON(990PCS)
 - CARTON WEIGHT:
 - 4.1 NET WEIGHT: 8.9 KG
 - 4.2 GROSS WEIGHT: 9.9 KG

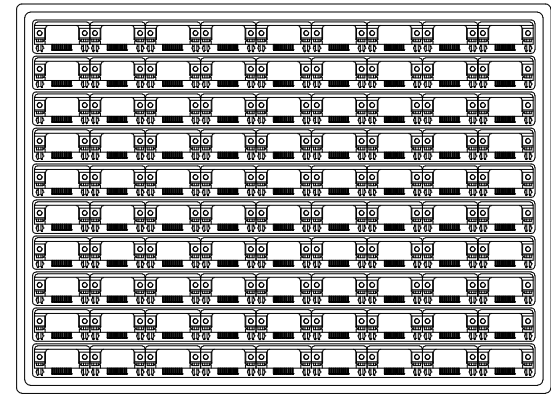
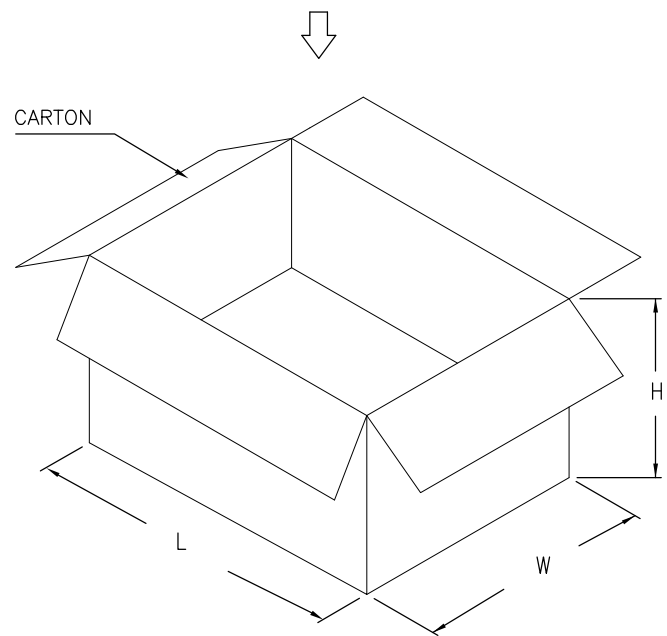

THIS DRAWING IS A CONTROLLED DOCUMENT.		DWN J. LEE 17NOV2006		NAME												
DIMENSIONS: MM		CHK S. HOU 17NOV2006		RECEPTACLE ASSEMBLY, 9 POSN, RIGHT ANGLE, 8.08mm[0.318in] SERIES, AMPLIMITE, WITH SCREWLOCKS												
TOLERANCES UNLESS OTHERWISE SPECIFIED:		APVD W.J. KE 17NOV2006	PRODUCT SPEC	SIZE	CAGE CODE											
<table border="1"> <tr><td>0 PLC</td><td>±</td></tr> <tr><td>1 PLC</td><td>±</td></tr> <tr><td>2 PLC</td><td>±</td></tr> <tr><td>3 PLC</td><td>±</td></tr> <tr><td>4 PLC</td><td>±</td></tr> <tr><td>ANGLES</td><td>±</td></tr> </table>		0 PLC	±	1 PLC	±	2 PLC	±	3 PLC	±	4 PLC	±	ANGLES	±	APPLICATION SPEC	DRAWING NO	RESTRICTED TO
0 PLC	±															
1 PLC	±															
2 PLC	±															
3 PLC	±															
4 PLC	±															
ANGLES	±															
MATERIAL	FINISH	WEIGHT	A3 00779	C=1734354	-											
CUSTOMER DRAWING			SCALE	SHEET	REV											
			-	2 of 2	A1											