

ISOMETRIC

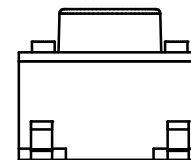

NOTES:

1. ALL DIMENSIONS IN MM
2. GENERAL TOLERANCE: X.X=±0.4  
X.XX=±0.25
3. TERM. NOS. FOR REFERENCE ONLY.
4. RATING: 50VDC, 50mA
- ▲ 5. OPERATING FORCE: 260 ± 50 gms
6. TRAVEL: 0.3mm ± 0.15
7. CONTACT RESISTANCE: 100 MILLI OHMS MAX. (INITIAL)
8. MECHANICAL/ELECTRICAL LIFE 100,000 CYCLES MIN.
- ▲ 9. SILVER CONTACTS
- ▲ 10. PACKAGE: TAPE AND REEL, 1000 PIECES PER REEL
11. ▲ DENOTES CRITICAL PARAMETER

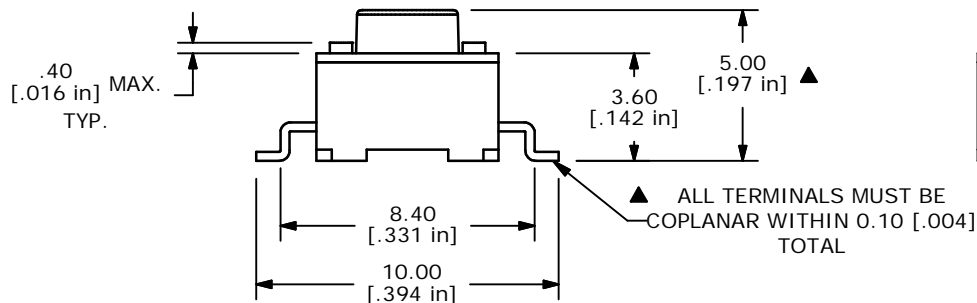
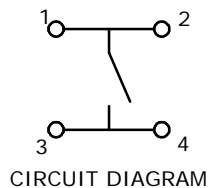

25-05278

**E-SWITCH®**

TITLE TL3301AF260QG

B	14817	REVISED AND REDRAWN	4/1/05	AR
REV	PCR NO	DESCRIPTION	DATE	BY

THE INFORMATION CONTAINED IN THIS DOCUMENT IS PROPRIETARY TO E-SWITCH AND IS NOT TO BE COPIED OR TRANSFERRED

SCALE	DATE	DR	DWG	REV
4:1	7/29/02	CJB	D310513	B